

Excellent Integrated System Limited

Stocking Distributor

Click to view price, real time Inventory, Delivery & Lifecycle Information:

[Schurter](#)
[6162.0031](#)

For any questions, you can email us directly:
sales@integrated-circuit.com

IEC Appliance Inlet C18, Snap-in Mounting, Solder, Quick-connect, Screw- or PCB Terminal



Snap-In Version



Description

- Panel Mount:
 - Snap-in version, Front Side
- 1 Function
- Appliance Inlet, Pin temperature 70 °C, Protection class II
- Solder, quick-connect, screw, PCB

Approvals

- VDE Certificate Number: 40011871
- CSA File Number: 27324

References

Alternative: protection class I version [6010](#)

Weblinks

[pdf-datasheet](#), [html-datasheet](#), [General Product Information](#), [RoHS](#), [CHINA-RoHS](#), [REACH](#), [Distributor-Stock-Check](#), [Accessories](#), [Detailed request for product](#)

Technical Data

Ratings IEC	10A / 250VAC; 50Hz	Appliance Inlet	C18 acc. to IEC 60320-1 UL 498, CSA C22.2 no. 42 (for cold conditions) pin-temperature 70 °C, 10A, Protection Class II
Ratings UL/CSA	15A / 250VAC; 60Hz		
Dielectric Strength	> 3kVAC between L-N > 1.5kVAC between L/N-PE (1 min/50Hz)		
Allowable Operation Temp.	-25 °C to 70 °C		
Degree of Protection	from front side IP 20 acc. to IEC 60529		
Protection Class	Suitable for appliances with protection class II acc. to IEC 61140		
Terminal	Solder, quick-connect, screw, PCB		
Panel Thickness s	Snap-in version 0.8/1.0/1.2/1.5/2.0/2.5/3.0/4.0 mm		
Material: Housing	PA6, black or grey, UL 94V-0		

Dimensions

Quick connect or solder terminals

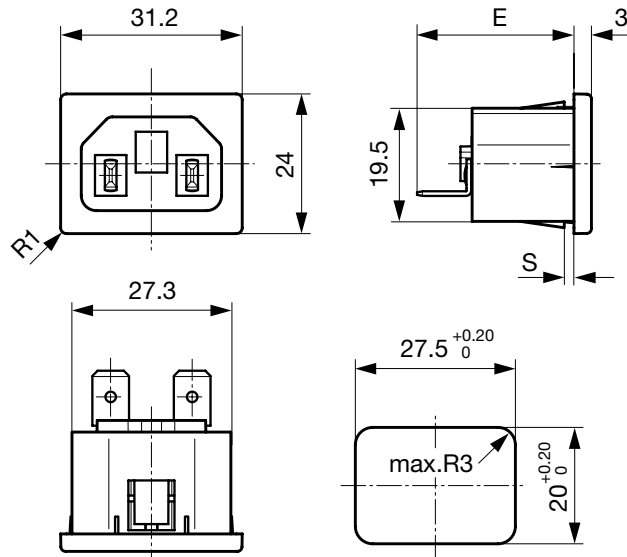

E: Quick-connect terminals 4.8x0.8 mm: 27.0 mm
 E: Quick-connect terminals 6.3x0.8 mm: 28.0 mm
 E: Solder terminals short: 22.5 mm
 E: Solder terminals long: 26.2 mm
 Dimension "S" please ref. to table order code

Screw terminals

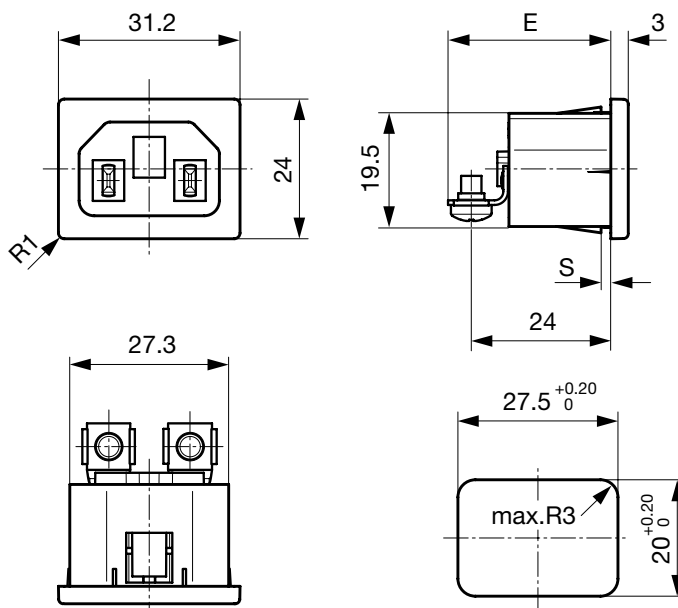

E: Screw terminals M3.5: 28.0 mm
 Dimension "S" please ref. to table order code

PCB terminals

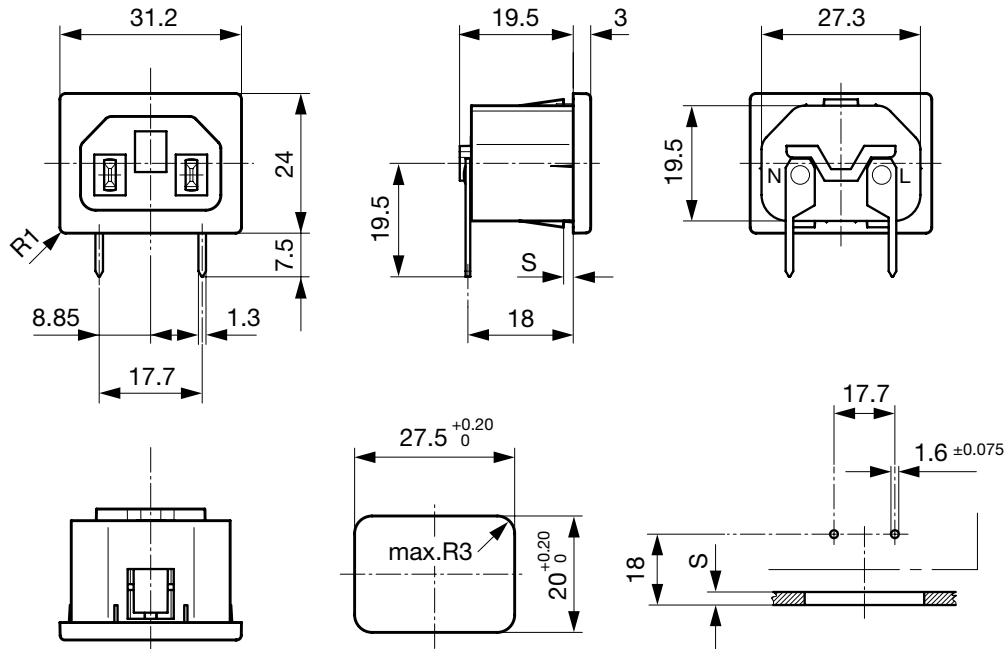

Dimension "S" please ref. to table order code

Config. Code





6015 - H - A B C 0 - D - E G 0

The characters are placeholders for the correspondingly keys of selections from the key tables.

6015 - H - A B C 0 - D - E G 0 = Type

Type	Configuration key
protection class II	X

6015 - H - A B C 0 - D - E G 0 = Terminals

Terminal L	Configuration key
short solder terminal (L = 4.8 mm) 	2
long solder terminal (L = 8.5 mm) 	3
PCB-terminal standard (additional solder terminal) 	4
Blade terminal (4.8 x 0.8 mm) 	8
Blade terminal (6.3 x 0.8 mm) 	9
screw terminal	A

6015 - H - A B C 0 - D - E G 0 = Terminals

Terminal N	Configuration key
short solder terminal (L = 4.8 mm)	2
long solder terminal (L = 8.5 mm)	3
PCB-terminal standard (additional solder terminal)	4
Blade terminal (4.8 x 0.8 mm)	8
Blade terminal (6.3 x 0.8 mm)	9
screw terminal	A

Symbols similar as in table A

6015 - H - A B C 0 - D - E G 0 = Terminals

Terminal Ground	Configuration key
without terminal	0

Symbols similar as in table A

6015 - H - A B C 0 - D - E G 0 = Color

Color	Configuration key
Black	A

6015

Connectors (Inlets/Outlets)
www.schurter.com/PG07

Color	Configuration key
Grey	B

Mass "s"	Configuration key
12	
15	
20	
25	
30	
40	

6015 - H - A B C 0 - D - E G O = Style

Style	Configuration key
snap-in (s=panel thickness)	4

The dimension "S" is displayed in ($\frac{1}{10}$ mm). This information is also valid for the order code

6015 - H - A B C 0 - D - E G O = Mass S

Mass "s"	Configuration key
08	
10	

The dimension "S" is displayed in ($\frac{1}{10}$ mm). This information is also valid for the order code

6015 - H - A B C 0 - D - E G O = Features

Features	Configuration key
without V-Lock	
V-Lock	V

All Variants

Terminals L / N	Color	Panel Thickness s [1/10 mm]	Features	Config. Code	Order Number
short solder terminal (L = 4.8 mm)	Black	15	-	6015-X-2200-A-415	6162.0032
short solder terminal (L = 4.8 mm)	Black	30	-	6015-X-2200-A-430	6162.0033
Blade terminal (4.8 x 0.8 mm)	Black	15	-	6015-X-8800-A-415	6162.0035
Blade terminal (4.8 x 0.8 mm)	Black	20	-	6015-X-8800-A-420	6162.0036
Blade terminal (4.8 x 0.8 mm)	Black	25	-	6015-X-8800-A-425	6162.0037
Blade terminal (6.3 x 0.8 mm)	Black	30	-	6015-X-9900-A-430	6162.0039

The listed variants should be available from stock. Other versions on request www.schurter.com/contact

Availability for all products can be searched real-time: <http://www.schurter.com/Stock-Check/Stock-Check-SCHURTER>

Packaging unit 50 Pcs

Accessories

Description

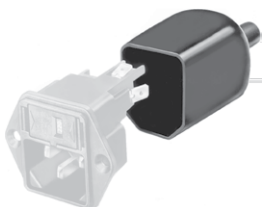

Assorted Covers
Rear Cover

Mating Outlets/Connectors

Category / Description

[Connector Overview complete](#)



4782 Mounting: Power Cord, 3 x 1 mm ² / 3 x 18 AWG, Cable, Connector: IEC C13	4782
4022 Mounting: Power Supply Cord, 3 x 1.5 mm ² , Screw clamps, Connector: IEC C13	4022
4785 Mounting: Power Cord, 3 x 1 mm ² / 3 x 18 AWG, Cable, Connector: IEC C13	4785
4300-06 Mounting: Power Cord, 3 x 1 mm ² / 3 x 18 AWG, Cable, Connector: IEC C13	4300-06
4012 Mounting: Power Supply Cord, 3 x 1.5 mm ² , Screw clamps, Connector: IEC C13	4012
Connector further types to 6015	...

Mating Outlets/Connectors shuttered

[Power Cord Overview complete](#)



VAC17KS, North America, V-Lock cord retaining, 2.0 m, Connector C17, cord end:	6051.2801
VAC17KS, North America, V-Lock cord retaining, 2.0 m, Connector C17, cord end:	6051.2811
VAC17KS, United Kingdom, V-Lock cord retaining, 2.0 m, Connector IEC C17, cord end:	3-101-184
VAC17KS, Switzerland, V-Lock cord retaining, 2.0 m, Connector IEC C17, cord end:	3-101-185
VAC17KS, Europlug, V-Lock cord retaining, 2.0 m, Connector IEC C17, cord end:	6051.2803
Power Cord further types to 6015	...