

Excellent Integrated System Limited

Stocking Distributor

Click to view price, real time Inventory, Delivery & Lifecycle Information:

[Knowles](#)

[GQ-30783-000](#)

For any questions, you can email us directly:

sales@integrated-circuit.com

GQ-30783-000
SHT 1.1

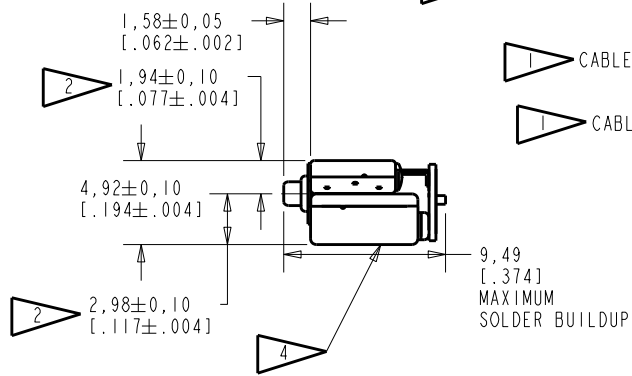
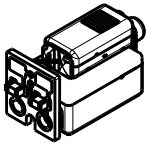
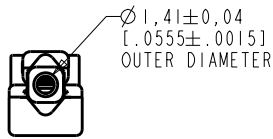
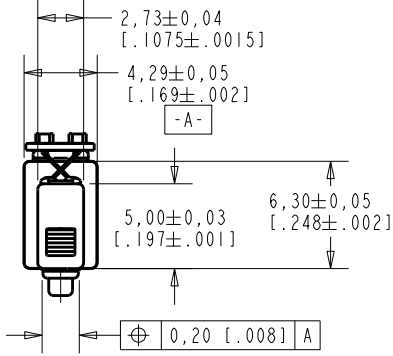

NOTES:

- 1 A POSITIVE GOING VOLTAGE AT THE POSITIVE TERMINAL RELATIVE TO THE NEGATIVE TERMINAL CAUSES A DECREASE IN PRESSURE AT THE SOUND OUTLET.
- 2 LOCATED FROM TWO SURFACES FOR CUSTOMER CONVENIENCE. ONLY APPLICABLE FROM ONE SURFACE, NOT TO BE USED TOGETHER.
- 3 BACK VENT HOLE TO BE CLEAN AND CLEAR OF DEBRIS.
- 4 LASER MARK ON OUTSIDE OF ED CUP.

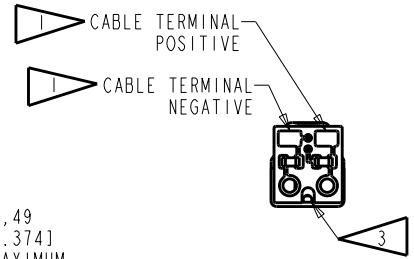

DIMENSIONS IN MILLIMETERS [INCHES]

KNOWLES ELECTRONICS
ITASCA, ILLINOIS U.S.A.

Revision	C.O. #	Implementation Date	RELEASE LEVEL	REVISION
			Active	D
D	C10116006	6-6-14		
SCALE: 3:1			DR. BY DATE	
DO NOT SCALE DRAWING			MMM 7-28-09	
TITLE: RECEIVER			GJP 7-30-09	
OUTLINE DRAWING			APP. BY DATE	
			GJP 7-30-09	
			KE111AS1ZE.FRM	
			Rev: B	

GQ-30783-000
SHT 1.1

UNDAMPED MAGNETIC BALANCED ARMATURE RECEIVERS INTENDED FOR USE AS THE HIGH AND LOW FREQUENCY DRIVERS IN A Hi Fi SYSTEM. THE GQ RECEIVER COMBINES A WBFK AND ED RECEIVERS COUPLED THROUGH A CIRCUIT TO PROVIDE THE RESPONSE SHAPE.

NO DAMPING

GQ-30783-000
SHEET 2.1

CONSTANT VOLTAGE DRIVE CONDITIONS
TESTED WITH VENT UNSEALED

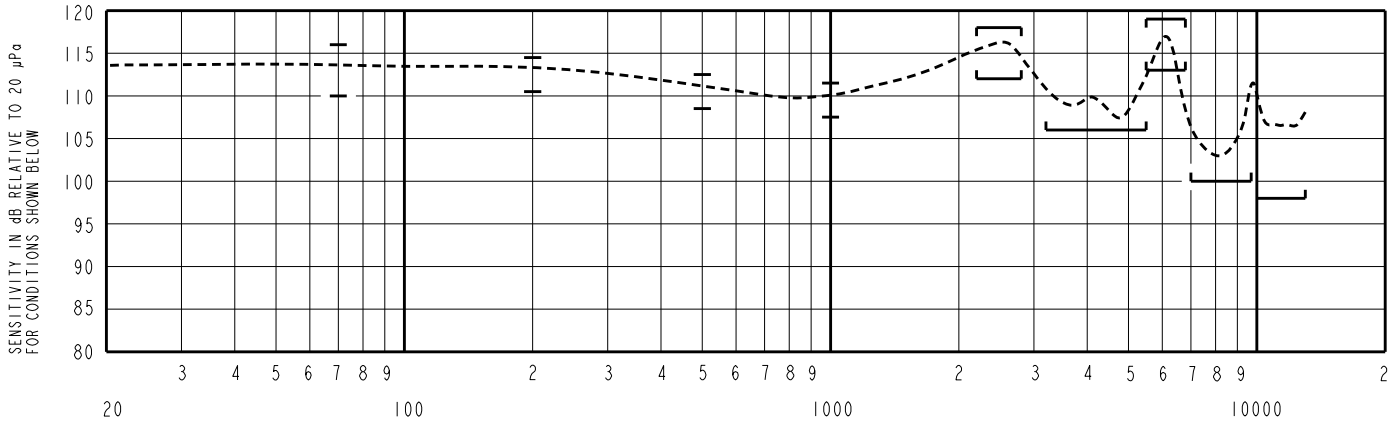

TEST CONDITIONS

NOMINAL SOURCE VOLTAGE	0.101 V rms, 0 V DC BIAS
SOURCE IMPEDANCE	<1 Ohm
TUBING	7 X 2 mm + 0.188cc CAVITY
COUPLER CAVITY	IEC 60318-4 ("711")
TEST STATION	FCAAT

TABLE 1

ACOUSTICAL

SENSITIVITY
DEVICE WILL PRODUCE THE SPL LISTED BELOW UNDER TEST CONDITIONS IN TABLE 1. NOMINAL SENSITIVITY AT 1kHz IS dB RELATIVE TO 20 µPa. ALL OTHER VALUES IN dB RELATIVE TO THE SENSITIVITY AT 1kHz.

FREQUENCY (Hz)	MINIMUM	NOMINAL	MAXIMUM
70	+0.5	+3.5	+6.5
200	+1.0	+3.0	+5.0
500	-1.0	+1.0	+3.0
1000	-2.0	109.5	+2.0
2200 - 2800	+2.5	+6.0	+8.5
3200 - 5500	-3.5	---	---
5500 - 6800	+3.5	+6.5	+9.5
7000 - 9700	-9.5	---	---
10000 - 13000	-11.5	---	---

TABLE 2

TOTAL HARMONIC DISTORTION

DEVICE WILL NOT EXCEED TOTAL HARMONIC DISTORTION LEVELS LISTED BELOW.

FREQUENCY (Hz)	AC DRIVE (V rms)	DC BIAS (mA)	LIMIT (%)
500	0.202	0	8
830	0.101	0	5
1250	0.101	0	5

TABLE 3

ELECTRICAL

DC RESISTANCE	12.5 Ohms ± 10%
IMPEDANCE @ 500 Hz	21.5 Ohms ± 15%
IMPEDANCE @ 1kHz	39.4 Ohms ± 15%

TABLE 4

ISOLATION: CASE WILL BE ELECTRICALLY ISOLATED FROM THE COIL CIRCUIT.

MECHANICAL

PORT LOCATION: 12S
SOLDER TYPE: SAC305 (LEAD FREE)

TEMPERATURE:

OPERATING: SENSITIVITY AT 1K Hz WILL NOT VARY MORE THAN +1/-3 dB FROM 17°C TO 63°C.
STORAGE: -40°C TO 63°C.

BUZZ TEST

LISTENING TEST CONDUCTED BETWEEN 20Hz TO 3kHz TO DETECT BUZZ.

INPUT DRIVE SIGNAL	0.18V
--------------------	-------

TABLE 5