

## Excellent Integrated System Limited

Stocking Distributor

Click to view price, real time Inventory, Delivery & Lifecycle Information:

[Phoenix Contact](#)  
[2800467](#)

For any questions, you can email us directly:

[sales@integrated-circuit.com](mailto:sales@integrated-circuit.com)



Extract from the online catalog

## VAL-SQ SP 100-480D

Order No.: 2800467



<http://eshop.phoenixcontact.de/phoenix/treeViewClick.do?UID=2800467>

Surge protection device for 480 V AC Delta configurations. Uses a compact, NEMA rated enclosure that connects easily to an existing enclosure. Hybrid Sine Wave Tracking provides 100 kA surge protection.

### Commercial data

GTIN (EAN)	 4 046356 565011
Note	Made-to-order
sales group	J102
Pack	1 pcs.
Customs tariff	85363090
Catalog page information	Page 77 (TT-2011)

<http://www.download.phoenixcontact.com>  
 Please note that the data given here has been taken from the online catalog. For comprehensive information and data, please refer to the user documentation. The General Terms and Conditions of Use apply to Internet downloads.

### Product description

Surge protection device for 480 V AC Delta configurations with 100 kA protection

### Technical data

#### Standards

Degree of protection	NEMA 4X
Mounting type	3/4 inch NPT male
Design	Parallel hybrid
Ambient temperature (operation)	-40 °C ... 71 °C

VAL-SQ SP 100-480D Order No.: 2800467

<http://eshop.phoenixcontact.de/phoenix/treeViewClick.do?UID=2800467>

Altitude	3658 m
Message: Surge protection fault	Phase LEDs
	Audible alarm
	Remote indicator contact
Direction of action	3L-N & N-GND
Width	250.00 mm
Height	122.00 mm

**Protective circuit**

Arrester rated voltage $U_c$	840 V
Response time	< 1 ns

**Connection, protective circuit**

Connection method	#10 AWG/5.26 mm <sup>2</sup> wires (24 in./61 cm long)
	4-wire + Gnd
Conductor cross section AWG/kcmil min.	10
Conductor cross section AWG/kcmil max	10

**Remote indicator contact**

Connection method	#24 AWG/0.205 mm <sup>2</sup> wires (24 in./61 cm long)
-------------------	---

**NEMA / UL data**

UL type	type 2
Maximum Continuous Operating Voltage (MCOV without reference direction)	840 V
Voltage protection rating (VPR L-L)	3000 V
Voltage protection rating (VPR L-PE)	1200 V
Nominal discharge current $I_n$ (without reference direction)	20 kA
Maximum Surge Current per Phase	100 kA
Short-circuit current rating (SCCR)	200 kA
EMI/RFI filtering	-30 dB @ 100 kHz

**Environmental conditions**

Standards/regulations	UL 1449 3 <sup>rd</sup> edition, Sept. 2009
	UL 1283
	IEEE C62.41
	IEEE C62.45

VAL-SQ SP 100-480D Order No.: 2800467

<http://eshop.phoenixcontact.de/phoenix/treeViewClick.do?UID=2800467>

## Diagrams/Drawings

Circuit diagram

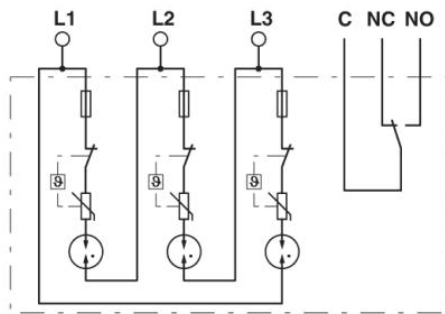

VAL-SQ SP 100-480D Order No.: 2800467  
<http://eshop.phoenixcontact.de/phoenix/treeViewClick.do?UID=2800467>

---

**Address**

PHOENIX CONTACT Inc., USA  
586 Fulling Mill Road  
Middletown, PA 17057, USA  
Phone (800) 888-7388  
Fax (717) 944-1625  
<http://www.phoenixcon.com>



© 2011 Phoenix Contact  
Technical modifications reserved;