

Excellent Integrated System Limited

Stocking Distributor

Click to view price, real time Inventory, Delivery & Lifecycle Information:

[Molex Connector Corporation](#)
[0638853900](#)

For any questions, you can email us directly:

sales@integrated-circuit.com

Air Feed Mylar Tape Applicator



**Mini-Mac Applicator
Application Tooling Specification
Air Feed-Mylar Tape
Part No. 63885-3900**

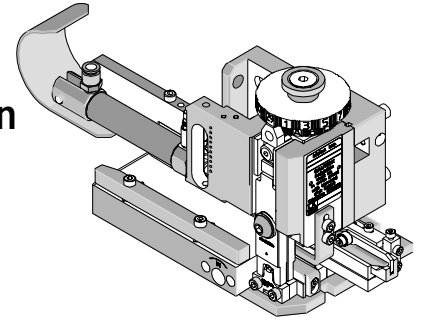

FEATURES

- Directly adapts to most crimp presses and automatic wire processors
- Applicator designed to industry-standard mounting and shut height of 135.80mm (5.346")
- Conductor and insulation rings allow quick adjustment for conductor and insulation crimp height change
- Quick set-up time; plus the crimp height, track and feed adjustments can be set without removing the applicator from the crimp press

SCOPE

Products: Krimptite™ / Versakrimp™ Ring, Spade, Rectangular, Hook, Flanged, and Wire Pin Terminals
14-16AWG.

Testing

Mechanical

The tensile test, or pull test, is a means of evaluating the mechanical properties of the crimped connections. The following chart shows the UL and government specifications (MIL-T-7928) for various wire sizes. The tensile strength is shown in pounds and indicates the minimum acceptable force to break or separate the terminal from the conductor.

Color Code	Wire Size (AWG)	*UL - 486 A	*UL - 486 C	*UL - 310	*Military Class 2
Blue	16	30	15	30	50
Blue	14	50	25	50	70

*UL - 486 A - Terminals (Copper conductors only)

*UL - 486 C - Butt Splices, Parallel Splices, Closed End Connectors, and Wire Nuts

*UL - 310 - Quick Disconnects, Flag and Couplers

*Military Class 2- Military Approved Terminals only as listed

Air Feed Mylar Tape Applicator

Product List

The following is a partial list of the product order numbers and their specifications that this tool is designed to run. Updates to this list are available on www.molex.com.

Terminal Order No.	Terminal Eng. No.	Wire Size		Insulation Diameter Maximum		Strip Length	
		AWG	mm ²	mm	In	mm	In
19069-0100	BB-123-04T	14-16	2.00-1.30	N/A	N/A	4.76	.187
19069-0102	BB-123-06T	14-16	2.00-1.30	N/A	N/A	4.76	.187
19069-0104	BB-123-08T	14-16	2.00-1.30	N/A	N/A	4.76	.187
19069-0106	BB-125-10T	14-16	2.00-1.30	N/A	N/A	4.76	.187
19069-0108	BB-125-14T	14-16	2.00-1.30	N/A	N/A	4.76	.187
19069-0110	BB-125-56T	14-16	2.00-1.30	N/A	N/A	4.76	.187
19069-0113	BB-137-06T	14-16	2.00-1.30	N/A	N/A	4.76	.187
19069-0115	BB-137-08T	14-16	2.00-1.30	N/A	N/A	4.76	.187
19069-0117	BB-137-10T	14-16	2.00-1.30	N/A	N/A	4.76	.187
19069-0122	BB-139-08T	14-16	2.00-1.30	N/A	N/A	4.76	.187
19069-0124	BB-139-10T	14-16	2.00-1.30	N/A	N/A	4.76	.187
19069-0134	BB-123-02T	14-16	2.00-1.30	N/A	N/A	4.76	.187
19069-0135	BB-123-04BT	14-16	2.00-1.30	N/A	N/A	4.76	.187
19069-0136	BB-137-04T	14-16	2.00-1.30	N/A	N/A	4.76	.187
19069-0137	BB-139-04T	14-16	2.00-1.30	N/A	N/A	4.76	.187
19069-0138	BB-139-06T	14-16	2.00-1.30	N/A	N/A	4.76	.187
19087-0097	BB-113-04T	14-16	2.00-1.30	N/A	N/A	4.76	.187
19087-0099	BB-113-06T	14-16	2.00-1.30	N/A	N/A	4.76	.187
19087-0101	BB-113-08T	14-16	2.00-1.30	N/A	N/A	4.76	.187
19087-0105	BB-182-06T	14-16	2.00-1.30	N/A	N/A	4.76	.187
19087-0107	BB-182-08T	14-16	2.00-1.30	N/A	N/A	4.76	.187
19087-0109	BB-182-10T	14-16	2.00-1.30	N/A	N/A	4.76	.187
19087-0114	BB-185-06T	14-16	2.00-1.30	N/A	N/A	4.76	.187
19087-0116	BB-185-08T	14-16	2.00-1.30	N/A	N/A	4.76	.187
19087-0118	BB-185-10T	14-16	2.00-1.30	N/A	N/A	4.76	.187
19087-0123	BB-188-04T	14-16	2.00-1.30	N/A	N/A	4.76	.187
19087-0125	BB-188-06T	14-16	2.00-1.30	N/A	N/A	4.76	.187
19087-0127	BB-188-08T	14-16	2.00-1.30	N/A	N/A	4.76	.187
19087-0129	BB-188-10T	14-16	2.00-1.30	N/A	N/A	4.76	.187
19093-0040	BB-313-04T	14-16	2.00-1.30	N/A	N/A	4.76	.187
19093-0042	BB-313-06T	14-16	2.00-1.30	N/A	N/A	4.76	.187
19093-0044	BB-313-08T	14-16	2.00-1.30	N/A	N/A	4.76	.187
19093-0046	BB-382-06T	14-16	2.00-1.30	N/A	N/A	4.76	.187
19093-0048	BB-382-08T	14-16	2.00-1.30	N/A	N/A	4.76	.187
19093-0050	BB-382-10T	14-16	2.00-1.30	N/A	N/A	4.76	.187
19093-0052	BB-385-06T	14-16	2.00-1.30	N/A	N/A	4.76	.187
19093-0054	BB-385-08T	14-16	2.00-1.30	N/A	N/A	4.76	.187
19093-0056	BB-385-10T	14-16	2.00-1.30	N/A	N/A	4.76	.187
19093-0058	BB-388-04T	14-16	2.00-1.30	N/A	N/A	4.76	.187
19093-0060	BB-388-06T	14-16	2.00-1.30	N/A	N/A	4.76	.187
19093-0062	BB-388-08T	14-16	2.00-1.30	N/A	N/A	4.76	.187
19093-0064	BB-388-10T	14-16	2.00-1.30	N/A	N/A	4.76	.187
19098-0035	BB-1193-06T	14-16	2.00-1.30	N/A	N/A	4.76	.187
19098-0037	BB-1194-08T	14-16	2.00-1.30	N/A	N/A	4.76	.187
19098-0040	BB-1195-10T	14-16	2.00-1.30	N/A	N/A	4.76	.187
19098-0042	BB-1707-05T	14-16	2.00-1.30	N/A	N/A	4.76	.187
19098-0044	BB-1707-06T	14-16	2.00-1.30	N/A	N/A	4.76	.187
19098-0048	BB-1716-08T	14-16	2.00-1.30	N/A	N/A	4.76	.187
19098-0050	BB-1717-10T	14-16	2.00-1.30	N/A	N/A	4.76	.187
19098-0082	BB-1707-04T	14-16	2.00-1.30	N/A	N/A	4.76	.187
19118-0055	BB-116-06T	14-16	2.00-1.30	N/A	N/A	4.76	.187
19118-0057	BB-116-08T	14-16	2.00-1.30	N/A	N/A	4.76	.187
19118-0059	BB-116-10T	14-16	2.00-1.30	N/A	N/A	4.76	.187
19118-0069	BB-183-10T	14-16	2.00-1.30	N/A	N/A	4.76	.187
19118-0114	BB-116-04T	14-16	2.00-1.30	N/A	N/A	4.76	.187
19118-0115	BB-1491-06T	14-16	2.00-1.30	N/A	N/A	4.76	.187
19118-0117	BB-180-06T	14-16	2.00-1.30	N/A	N/A	4.76	.187

Terminal Order No.	Terminal Eng. No.	Wire Size		Insulation Diameter Maximum		Strip Length	
		AWG	mm ²	mm	In	mm	In
19118-0118	BB-180-08T	14-16	2.00-1.30	N/A	N/A	4.76	.187
19118-0119	BB-180-10T	14-16	2.00-1.30	N/A	N/A	4.76	.187
19118-0120	BB-183-06T	14-16	2.00-1.30	N/A	N/A	4.76	.187
19118-0121	BB-183-08T	14-16	2.00-1.30	N/A	N/A	4.76	.187
19118-0122	BB-186-04T	14-16	2.00-1.30	N/A	N/A	4.76	.187
19118-0123	BB-186-06T	14-16	2.00-1.30	N/A	N/A	4.76	.187
19118-0124	BB-186-08T	14-16	2.00-1.30	N/A	N/A	4.76	.187
19124-0034	BB-316-04T	14-16	2.00-1.30	N/A	N/A	4.76	.187
19124-0036	BB-316-06T	14-16	2.00-1.30	N/A	N/A	4.76	.187
19124-0038	BB-316-08T	14-16	2.00-1.30	N/A	N/A	4.76	.187
19124-0039	BB-316-10T	14-16	2.00-1.30	N/A	N/A	4.76	.187
19124-0044	BB-380-06T	14-16	2.00-1.30	N/A	N/A	4.76	.187
19124-0046	BB-380-08T	14-16	2.00-1.30	N/A	N/A	4.76	.187
19124-0048	BB-380-10T	14-16	2.00-1.30	N/A	N/A	4.76	.187
19124-0050	BB-383-06T	14-16	2.00-1.30	N/A	N/A	4.76	.187
19124-0052	BB-383-08T	14-16	2.00-1.30	N/A	N/A	4.76	.187
19124-0054	BB-383-10T	14-16	2.00-1.30	N/A	N/A	4.76	.187
19124-0056	BB-386-04T	14-16	2.00-1.30	N/A	N/A	4.76	.187
19124-0058	BB-386-06T	14-16	2.00-1.30	N/A	N/A	4.76	.187
19124-0060	BB-386-08T	14-16	2.00-1.30	N/A	N/A	4.76	.187
19129-0021	BB-1781-08T	14-16	2.00-1.30	N/A	N/A	4.76	.187
19129-0028	BB-1471-06T	14-16	2.00-1.30	N/A	N/A	4.76	.187
19129-0069	BB-1781-06T	14-16	2.00-1.30	N/A	N/A	4.76	.187
19129-0070	BB-181-06T	14-16	2.00-1.30	N/A	N/A	4.76	.187
19129-0071	BB-181-08T	14-16	2.00-1.30	N/A	N/A	4.76	.187
19129-0072	BB-181-10T	14-16	2.00-1.30	N/A	N/A	4.76	.187
19129-0073	BB-184-06T	14-16	2.00-1.30	N/A	N/A	4.76	.187
19129-0074	BB-184-08T	14-16	2.00-1.30	N/A	N/A	4.76	.187
19129-0075	BB-184-10T	14-16	2.00-1.30	N/A	N/A	4.76	.187
19129-0076	BB-187-04T	14-16	2.00-1.30	N/A	N/A	4.76	.187
19129-0077	BB-187-06T	14-16	2.00-1.30	N/A	N/A	4.76	.187
19129-0078	BB-187-08T	14-16	2.00-1.30	N/A	N/A	4.76	.187
19141-0051	BB-107-04T	14-16	2.00-1.30	N/A	N/A	4.76	.187
19141-0053	BB-107-06T	14-16	2.00-1.30	N/A	N/A	4.76	.187
19141-0055	BB-124-04T	14-16	2.00-1.30	N/A	N/A	4.76	.187
19141-0057	BB-124-06T	14-16	2.00-1.30	N/A	N/A	4.76	.187
19141-0059	BB-124-08T	14-16	2.00-1.30	N/A	N/A	4.76	.187
19141-0062	BB-127-06T	14-16	2.00-1.30	N/A	N/A	4.76	.187
19141-0064	BB-127-08T	14-16	2.00-1.30	N/A	N/A	4.76	.187
19141-0066	BB-127-10T	14-16	2.00-1.30	N/A	N/A	4.76	.187
19147-0041	BB-307-04T	14-16	2.00-1.30	N/A	N/A	4.76	.187
19147-0043	BB-307-06T	14-16	2.00-1.30	N/A	N/A	4.76	.187
19147-0045	BB-324-04T	14-16	2.00-1.30	N/A	N/A	4.76	.187
19147-0047	BB-324-06T	14-166	2.00-1.30	N/A	N/A	4.76	.187
19147-0049	BB-324-08T	14-16	2.00-1.30	N/A	N/A	4.76	.187
19147-0051	BB-327-06T	14-16	2.00-1.30	N/A	N/A	4.76	.187
19147-0053	BB-327-08T	14-16	2.00-1.30	N/A	N/A	4.76	.187
19147-0055	BB-327-10T	14-16	2.00-1.30	N/A	N/A	4.76	.187
19147-0063	BB-3781-10T	14-16	2.00-1.30	N/A	N/A	4.76	.187
19147-0065	BB-381-06T	14-16	2.00-1.30	N/A	N/A	4.76	.187
19147-0067	BB-381-08T	14-16	2.00-1.30	N/A	N/A	4.76	.187
19147-0069	BB-381-10T	14-16	2.00-1.30	N/A	N/A	4.76	.187
19147-0071	BB-384-06T	14-16	2.00-1.30	N/A	N/A	4.76	.187
19147-0073	BB-384-08T	14-16	2.00-1.30	N/A	N/A	4.76	.187
19147-0075	BB-384-10T	14-16	2.00-1.30	N/A	N/A	4.76	.187
19147-0077	BB-387-04T	14-16	2.00-1.30	N/A	N/A	4.76	.187
19147-0079	BB-387-06T	14-16	2.00-1.30	N/A	N/A	4.76	.187

Air Feed Mylar Tape Applicator

Terminal Order No.	Terminal Eng. No.	Wire Size		Insulation Diameter Maximum		Strip Length	
		AWG	mm ²	mm	In	mm	In
19147-0081	BB-387-08T	14-16	2.00-1.30	N/A	N/A	4.76	.187
19178-0009	BB-119-06T	14-16	2.00-1.30	N/A	N/A	4.76	.187
19178-0011	BB-119-08T	14-16	2.00-1.30	N/A	N/A	4.76	.187
19178-0013	BB-119-10T	14-16	2.00-1.30	N/A	N/A	4.76	.187
19180-0008	BB-319-06T	14-16	2.00-1.30	N/A	N/A	4.76	.187
19180-0010	BB-319-08T	14-16	2.00-1.30	N/A	N/A	4.76	.187
19180-0012	BB-319-10T	14-16	2.00-1.30	N/A	N/A	4.76	.187
19193-0054	BB-318-10T	14-16	2.00-1.30	N/A	N/A	4.76	.187
19193-0056	BB-318-14T	14-16	2.00-1.30	N/A	N/A	4.76	.187
19193-0058	BB-318-38T	14-16	2.00-1.30	N/A	N/A	4.76	.187
19193-0061	BB-318-56T	14-16	2.00-1.30	N/A	N/A	4.76	.187
19193-0063	BB-323-02T	14-16	2.00-1.30	N/A	N/A	4.76	.187
19193-0065	BB-323-04T	14-16	2.00-1.30	N/A	N/A	4.76	.187
19193-0067	BB-323-06T	14-16	2.00-1.30	N/A	N/A	4.76	.187
19193-0069	BB-323-08T	14-16	2.00-1.30	N/A	N/A	4.76	.187
19193-0071	BB-325-10T	14-16	2.00-1.30	N/A	N/A	4.76	.187
19193-0073	BB-325-14T	14-16	2.00-1.30	N/A	N/A	4.76	.187
19193-0075	BB-325-56T	14-16	2.00-1.30	N/A	N/A	4.76	.187
19193-0077	BB-337-04T	14-16	2.00-1.30	N/A	N/A	4.76	.187

Terminal Order No.	Terminal Eng. No.	Wire Size		Insulation Diameter Maximum		Strip Length	
		AWG	mm ²	mm	In	mm	In
19193-0079	BB-337-06T	14-16	2.00-1.30	N/A	N/A	4.76	.187
19193-0081	BB-337-08T	14-16	2.00-1.30	N/A	N/A	4.76	.187
19193-0083	BB-337-10T	14-16	2.00-1.30	N/A	N/A	4.76	.187
19193-0086	BB-339-04T	14-16	2.00-1.30	N/A	N/A	4.76	.187
19193-0088	BB-339-06T	14-16	2.00-1.30	N/A	N/A	4.76	.187
19193-0090	BB-339-08T	14-16	2.00-1.30	N/A	N/A	4.76	.187
19193-0092	BB-339-10T	14-16	2.00-1.30	N/A	N/A	4.76	.187
19203-0057	BB-T-323-06T	14-16	2.00-1.30	N/A	N/A	4.76	.187
19203-0058	BB-T-325-14T	14-16	2.00-1.30	N/A	N/A	4.76	.187
19203-0060	BB-T-337-06T	14-16	2.00-1.30	N/A	N/A	4.76	.187
19203-0062	BB-T-337-08T	14-16	2.00-1.30	N/A	N/A	4.76	.187
19203-0064	BB-T-337-10T	14-16	2.00-1.30	N/A	N/A	4.76	.187
19203-0078	BB-U-123-06T	14-16	2.00-1.30	N/A	N/A	4.76	.187
19203-0080	BB-U-125-14T	14-16	2.00-1.30	N/A	N/A	4.76	.187
19203-0081	BB-U-125-56T	14-16	2.00-1.30	N/A	N/A	4.76	.187
19203-0082	BB-U-137-06T	14-16	2.00-1.30	N/A	N/A	4.76	.187
19203-0084	BB-U-137-08T	14-16	2.00-1.30	N/A	N/A	4.76	.187
19203-0086	BB-U-137-10T	14-16	2.00-1.30	N/A	N/A	4.76	.187
19211-0006	WP-1614T	14-16	2.00-1.30	N/A	N/A	4.76	.187

DEFINITION OF TERMS

The following illustrations are a generic terminal representation and not an exact image of any terminal listed in the scope.

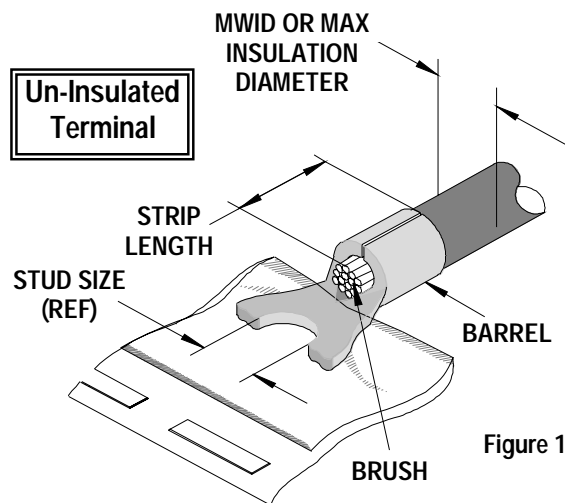

Air Feed Mylar Tape Applicator

Tool Calibration

To recalibrate this Applicator, make sure the power is completely shut off on the press.

1. The Mini-Mac applicator must be properly installed in the press.
2. Crimping dies must be properly installed in the Mini-Mac applicator.
3. The recommended method of measuring the crimp height of the conductor dies is the soft metal slug method. See Figure 4.
4. The slug must have a diameter 0.51mm (.020") larger than the "X" No Go dimension before crimping.
5. Place the soft metal slug (solder) into the nest of the bottom die and crimp (by hand cycling the press) similar to a terminal. The crimp height can be measured with a blade type micrometer or dial caliper, (Dimension "X").
6. Adjustment of the crimp height can be accomplished by indexing the conductor cam. The letter "A" gives the loosest position and "K" gives the tightest position. A total adjustment of 0.50mm (.020") can be achieved by adjusting the conductor cam.

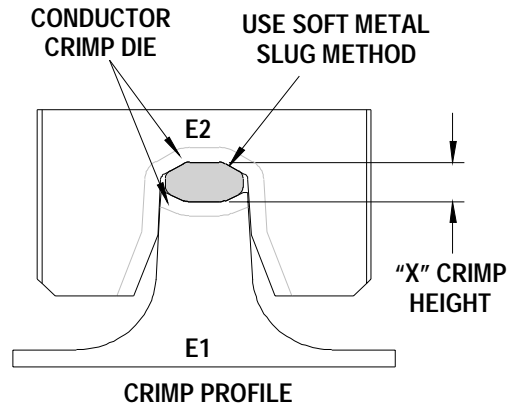

Use soft metal slug (solder) method to Measure the "X" dimension. Verify tooling crimp height calibration by referring to the Go/No Go dimensions shown in the chart below.

Figure 4

Note: If the crimp height is too tight on the setting "A", check the shut height of the press. See the Industrial Mini-Mac Applicator Manual Section 2.1 for adjustments.

CRIMP SPECIFICATIONS

Wire Size		"X" Dimension Conductor Crimp						Pull Force Minimum	
AWG	mm ²	Mean		Go		No Go		Lbs	N
		In	mm	In	mm	In	mm		
16	1.30	.085	2.15	.082	2.08	.092	2.33	30.0	133.5
14	2.00	.085	2.15	.082	2.08	.092	2.33	50.0	222.4

Pull Force should be measured with no influence from the insulation crimp. The above specifications are guidelines to an optimum crimp.

Air Feed Mylar Tape Applicator

PARTS LIST

Mini-Mac Applicator 63885-3900				
Item	Order No	Engineering No.	Description	Quantity
Perishable Tooling				
	63885-3970	63885-3970	Tool Kit (All "Y" Items)	REF
1	63465-0053	63465-0053	Conductor Punch	1 Y
2	63464-0053	63464-0053	Conductor Anvil	1 Y
Other Components (Ref. 850050)				
3	63443-0021	63443-0021	Lower Tooling Key	1
4	63466-0912	63466-0912	Anvil Mount	1
5	63466-0913	63466-0913	Terminal Support	1
6	63466-0921	63466-0921	Terminal Stripping Blade	1
7	63600-1290	63600-1290	Washer	1
8	63890-0866	63890-0866	Collar-6.4mm Long	1
9	63890-0867	63890-0867	Collar-7.7mm Long	1
Frame				
10	63801-3301	63801-3301	Air Feed Applicator Frame Head	1
11	63801-3281	63801-3281	Base	1
12	63801-5850	63801-5850	Track Assembly	1
13	63801-3390	63801-3390	Air Kit	1
Hardware				
14	N/A	N/A	M3 by 12 Long SHCS	1**
15	N/A	N/A	M4 by 10 Long SHCS	2**
16	N/A	N/A	M4 by 16 Long SHCS	1**
17	N/A	N/A	M4 by 45 Long SHCS	1**
18	N/A	N/A	M8 by 30 Long BHCS	1**
19	N/A	N/A	3mm by 6 Long Roll Pin	1**
** Available from an industrial supply company such as MSC (1-800-645-7270).				

Note: Crimp profiles used in 63885-3900 are equivalent to 19027-0068 / ATP-BB-120 (UL file number E32244).

Air Feed Mylar Tape Applicator

Assembly Drawing

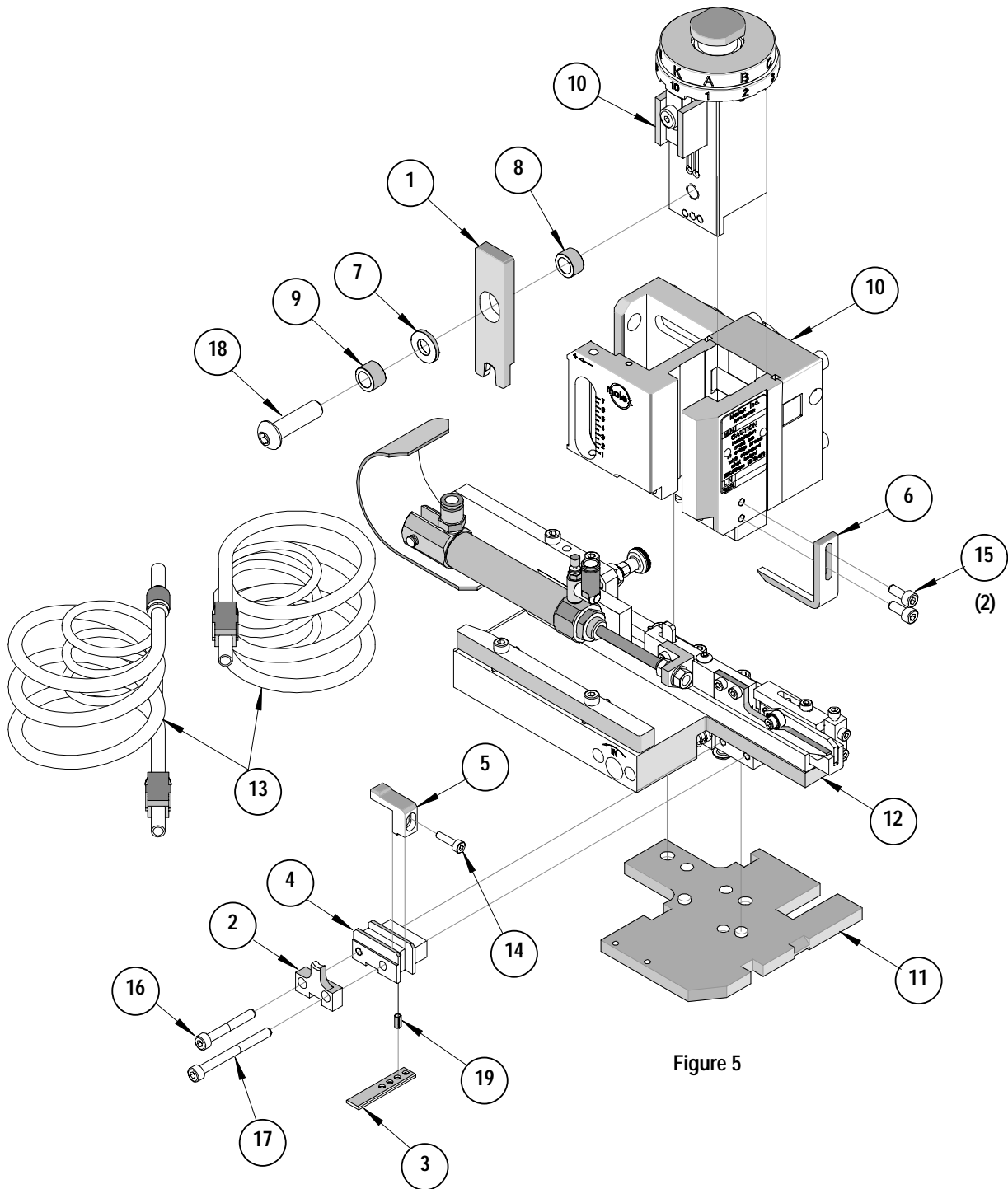

Figure 5

Air Feed Mylar Tape Applicator

NOTES

1. Molex recommends an extra perishable tooling kit be maintained at your facility.
2. Verify tooling alignment by manually cycling the press with applicator before crimping under power. Check that all screws are tight.
3. Slugs, terminals, dirt, and oil should be kept clear of work area.
4. Wear safety glasses at all times.
5. For recommended maintenance refer to the Mini-Mac Applicator Manual (Document no. 63880-0000).

CAUTION: This applicator should only be used in a press with a shut height of 135.80 mm (5.346"). Tooling damage could result at a lower setting.

CAUTION: To prevent injury, never operate this applicator without the guards supplied with the press or wire-processing machine in place. Reference the press or wire processing manufacturer's instruction manual.

CAUTION: Molex crimp specifications are valid only when used with Molex terminals, applicators and tooling.

Contact Information

For more information on Molex application tooling please contact Molex at 1-800-786-6539.

Americas Headquarters
Lisle, Illinois 60532 U.S.A.
1-800-78MOLEX
amerinfo@molex.com

Far East North Headquarters
Yamato, Kanagawa, Japan
81-462-65-2324
feninfo@molex.com

Far East South Headquarters
Jurong, Singapore
65-6-268-6868
fesinfo@molex.com

European Headquarters
Munich, Germany
49-89-413092-0
eurinfo@molex.com

Corporate Headquarters
2222 Wellington Ct.
Lisle, IL 60532 U.S.A.
630-969-4550
Fax: 630-969-1352

Visit our Web site at <http://www.molex.com>