

Excellent Integrated System Limited

Stocking Distributor

Click to view price, real time Inventory, Delivery & Lifecycle Information:

[Molex Connector Corporation](#)
[0639021000](#)

For any questions, you can email us directly:

sales@integrated-circuit.com

Fine Adjust Applicator for 1.80mm (.071") Diameter PC Board Crimp Terminal

FineAdjust Applicator	 Application Tooling Specification Sheet	 Order No. 63902-1000
----------------------------------	---	--

FEATURES

- Quick punch removal with the push of a button for fast and easy tooling change
- Applicator designed to industry standard mounting and shut height 135.80mm (5.346")
- Quick set-up time; plus the crimp height, track and feed adjustments can be set without removing the applicator from the press
- Fine adjustment allows users to achieve target with little effort by adjusting in increments of .015mm (.0006") for conductor crimp height and .063mm (.0025") for insulation height
- Independent adjustment rings allow users to quickly adjust the conductor or insulation crimp height without affecting each other
- Directly adapts to most automatic wire processing machines

SCOPE

Products: 1.80mm (.071") Diameter PC Board Crimp Terminal, 18-22 AWG.

Terminal Series No.	Terminal Order No.	Wire Size		Insulation Diameter				Strip Length	
				IPC/WHMA-A60 (1)		Terminal (2)			
		AWG	mm ²	mm	In.	mm	In.	mm	In.
35740	35740-1410	18	0.80	2.30-3.00	.091-.118	1.70-3.00	.067-.118	4.2-4.8	.165-.189
		20	0.50						
		22	0.35						

(1) To achieve optimum IPC-A620 Class 2 insulation crimps, use this insulation OD.
 (2) Overall insulation OD specification for terminal.

DEFINITION OF TERMS

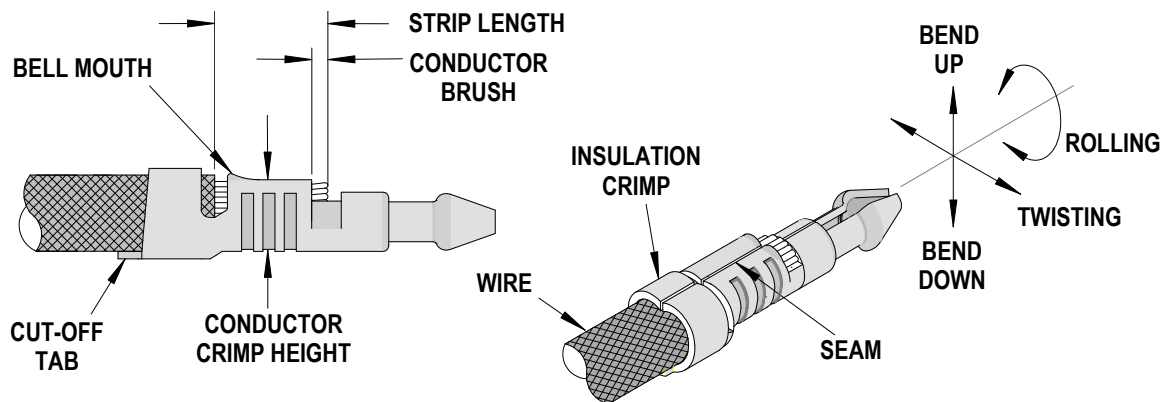

Fine Adjust Applicator for 1.80mm (.071") Diameter PC Board Crimp Terminal

CRIMP SPECIFICATION

Terminal Series No.	Bell mouth		Cut-off Tab Maximum		Conductor Brush	
	mm	In.	mm	In.	mm	In.
35740	0.15-0.30	.006-.012	0.50	.020	0.30-0.80	.012-.032

Terminal Series No.	Bend up Bend down		Twist	Roll	Punch Width (Ref)				Seam Seam shall not be open and no wire allowed out of the crimping area
	Degree Maximum				Degree Maximum		Conductor		
	mm	In	mm	In	mm	In	mm	In	
35740	8	8	8	10	2.10	.083	2.90	.114	

After crimping, the conductor profile should measure the following.

Terminal Series No.	Wire Size		Conductor				Insulation				Pull Force Minimum	
			Crimp Height		Crimp Width (Ref)		Crimp Height (Ref)		Crimp Width (Ref)			
	AWG	mm ²	mm	In.	mm	In.	mm	In.	mm	In.	N	Lb.
35740	18	0.80	1.25-1.35	.049-.053	2.10-2.30	.083-.091	3.55	.140	2.90-3.10	.114-.122	88.26	19.84
	20	0.50	1.15-1.25	.045-.049	2.10-2.30	.083-.091	3.45	.136	2.90-3.10	.114-.122	58.84	13.23
	22	0.35	1.05-1.15	.041-.045	2.10-2.30	.083-.091	3.35	.132	2.90-3.10	.114-.122	39.23	8.82

Tool Qualification Notes:

1. Pull Force should be measured with no influence from the insulation crimp.
2. The above specifications are guidelines to an optimum crimp.

Fine Adjust Applicator for 1.80mm (.071") Diameter PC Board Crimp Terminal

PARTS LIST

FineAdjust Applicator 63902-1000				
Item	Order No	Engineering No.	Description	Quantity
Perishable Tooling				
	63902-1070	63902-1070	Tool Kit (All "Y" Items)	REF
1	63444-2133	63444-2133	Conductor Punch	1 Y
2	63445-2155	63445-2155	Conductor Anvil	1 Y
3	63446-2929	63446-2929	Insulation Punch	1 Y
4	63445-2947	63445-2947	Insulation Anvil	1 Y
5	63443-0005	63443-0005	Front Cut-Off Plunger	1 Y
6	63443-0012	63443-0012	Front Plunger Retainer	1 Y
Other Components				
7	11-18-4083	60707-8	Feed Guide	1
8	11-24-1067	4996-4	Cut-Off Plunger Spring	1
9	63443-0009	63443-0009	Front Scrap Chute	1
10	63443-0024	63443-0024	Key	1
11	63443-0090	63443-0090	Wire Stop	1
12	63443-1719	63443-1719	Height Spacer	1
13	63443-2214	63443-2214	Coarse Spacer (14.00mm)	1
14	63443-2312	63443-2312	Fine Spacer (3.60mm)	1
15	63443-3101	63443-3101	Front Plunger Striker	1
16	63443-6117	63443-6117	Rear Cover	1
Frame				
17	63800-4901	63800-4901	Top	1
18	63801-3281	63801-3281	Base	1
19	63801-4650	63801-4650	Track	1
Hardware				
20	N/A	N/A	M3 by 6 Long SHCS	2**
21	N/A	N/A	M3 by 6 Long FHCS	1**
22	N/A	N/A	M4 by 6 Long SHCS	2**
23	N/A	N/A	M4 by 12 Long BHCS	2**
24	N/A	N/A	M4 by 50 Long SHCS	2**
25	N/A	N/A	M5 by 12 Lg SHCS	1**
26	N/A	N/A	#10-32 by 3/8" Long Flat Point SSS	1**
27	N/A	N/A	#10-32 Hex Jam Nut	1**

** Available from an industrial supply company such as MSC (1-800-645-7270).

Fine Adjust Applicator for 1.80mm (.071") Diameter PC Board Crimp Terminal

Assembly Drawing

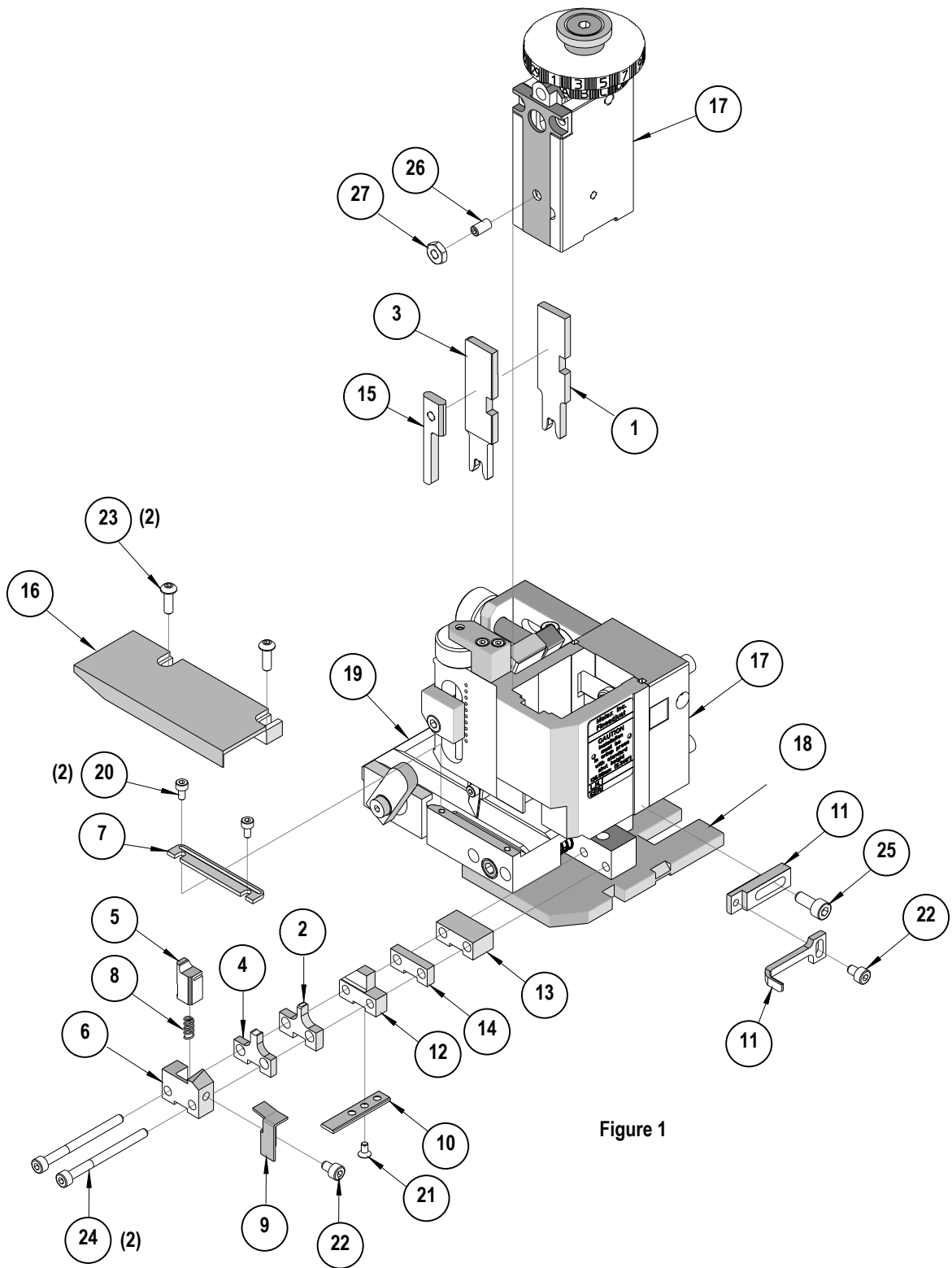

Figure 1

Fine Adjust Applicator for 1.80mm (.071") Diameter PC Board Crimp Terminal

NOTES

1. Molex recommends an extra perishable tooling kit be maintained at your facility.
2. Verify tooling alignment by manually cycling the press and Applicator before crimping under power. Check that all screws are tight.
3. Slugs, Terminals, Dirt and Oil should be kept clear of work area.
4. Wear safety glasses at all times.
5. For recommended maintenance refer to the FineAdjust Manual.

CAUTION: This applicator should only be used in a press with a shut height of 135.8mm (5.346"). Tooling damage could result at a lower setting.

CAUTION: To prevent injury never operate this Applicator without the guards supplied with the press or wire-processing machine in place. Reference the press or wire processing manufacturer's instruction manual.

CAUTION: Molex crimp specifications are valid only when used with Molex terminals, applicators and tooling.

<http://www.molex.com>