

Excellent Integrated System Limited

Stocking Distributor

Click to view price, real time Inventory, Delivery & Lifecycle Information:

[Molex Connector Corporation](#)

[0761550634](#)

For any questions, you can email us directly:

sales@integrated-circuit.com

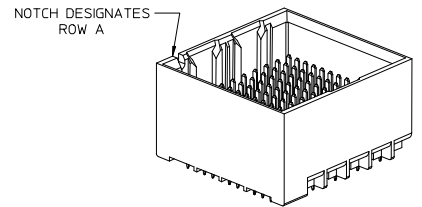
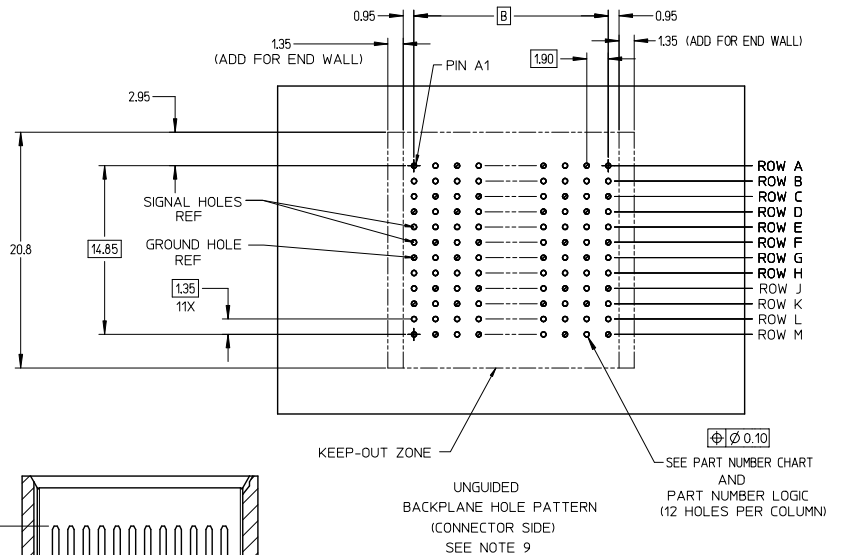
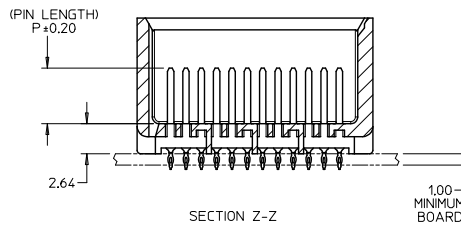
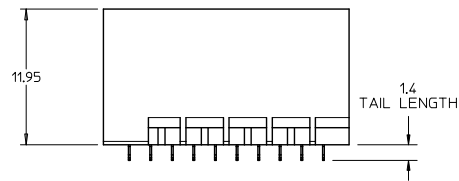
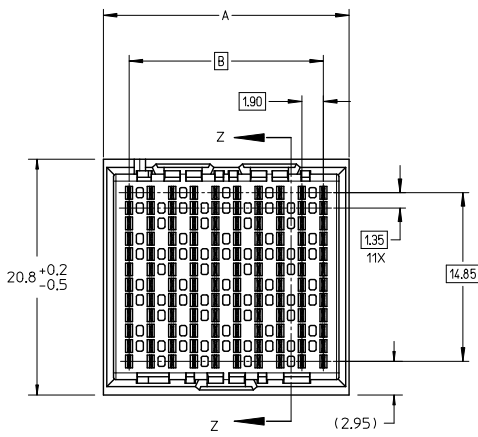

- NOTES:
1. MATERIALS: HOUSING - LIQUID CRYSTAL POLYMER (LCP)
GLASS-FILLED, UL94V-0
TERMINALS - HIGH PERFORMANCE COPPER ALLOY
 2. FINISH: 30µ MIN GOLD IN CONTACT AREA.
SELECTIVE TIN ON PCB TAILS.
NICKEL OVERALL.
 3. REFER TO MOLEX PRODUCT SPECIFICATION PS-76060-999 FOR PERFORMANCE SPECIFICATIONS AND ADDITIONAL PCB INFORMATION.
 4. THIS PART CONFORMS TO CLASS B REQUIREMENTS OF MOLEX COSMETIC SPEC PS-45499-002.
 5. PARTS PACKAGED PER PK-70873-7701.
 6. SEE SHEETS 2 & 3 FOR PART NUMBERS AND BOARD RELATIONSHIPS.
 7. MATES WITH IMPACT DC SERIES NO. 76160.
 8. REFER TO MOLEX PCB ROUTING GUIDE AS-76060-990 FOR ANTI PAD AND ROUTING RECOMMENDATIONS.
 9. *THESE DIMENSIONS REPRESENT THE AREA NEEDED TO ACCOMMODATE CONNECTOR INSERTION AND REPAIR ON THE PC BOARD. THIS IS REFERRED TO AS THE 'CONNECTOR KEEP OUT ZONE' AND DOES NOT REPRESENT THE ACTUAL PERIMETER OF THE CONNECTOR. WHEN LAYING OUT A PC BOARD FOR CONNECTORS STACKED TOGETHER, USE A 1.9mm PROGRESSION.*

CONVERT TO LEAD-FREE EC NO: UCP2015-2078 DRAWN BY: BARBARA 2012/11/28 CHKD: JB INGRAM 2012/12/18 APPR: SILLER 2012/12/21	QUALITY SYMBOLS ∇=0 ∇=0 ∇=0	GENERAL TOLERANCES (UNLESS SPECIFIED)		DIMENSION STYLE		SCALE	DESIGN UNITS	THIRD ANGLE PROJECTION		
				MM ONLY		4:1	METRIC			
						DRAWN BY	DATE	TITLE		
						CHECKED BY	DATE	IMPACT 4 PAIR HEADER UNGUIDED ASSEMBLY SALES DRAWING		
						APPROVED BY	DATE	molex		
						MATERIAL NO.	DOCUMENT NO.	SHEET NO.		
						SEE TABLE		SD-76155-001		
						THIS DRAWING CONTAINS INFORMATION THAT IS PROPRIETARY TO MOLEX INCORPORATED AND SHOULD NOT BE USED WITHOUT WRITTEN PERMISSION				

PART NUMBER TABLE

MATERIAL NUMBER	# OF COLUMNS	# OF DIFF PAIR	DIM 'A'	DIM 'B'	DUAL END WALL OPTION
76155-*32*	6	24	14.1	9.50	
76155-*82*	8	32	17.9	13.30	
76155-*12*	10	40	21.7	17.10	
76155-*62*	16	64	33.1	28.50	

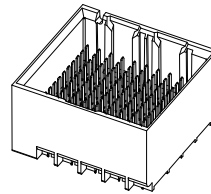

DUAL END
WALL
OPTION

MATERIAL NUMBER	# OF COLUMNS	# OF DIFF PAIR	DIM 'A'	DIM 'B'	LEFT END WALL OPTION
76155-*31*	6	24	12.7	9.50	
76155-*81*	8	32	16.5	13.30	
76155-*11*	10	40	20.3	17.10	
76155-*61*	16	64	31.7	28.50	

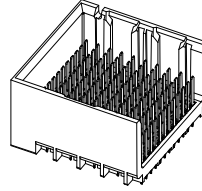

LEFT END
WALL
OPTION

MATERIAL NUMBER	# OF COLUMNS	# OF DIFF PAIR	DIM 'A'	DIM 'B'	RIGHT END WALL OPTION
76155-*33*	6	24	12.7	9.50	
76155-*83*	8	32	16.5	13.30	
76155-*13*	10	40	20.3	17.10	
76155-*63*	16	64	31.7	28.50	

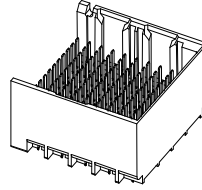

RIGHT END
WALL
OPTION

MATERIAL NUMBER	# OF COLUMNS	# OF DIFF PAIR	DIM 'A'	DIM 'B'	OPEN WALL OPTION
76155-*30*	6	24	11.3	9.50	
76155-*80*	8	32	15.1	13.30	
76155-*10*	10	40	18.9	17.10	
76155-*60*	16	64	30.4	28.50	

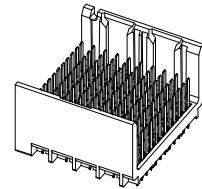

OPEN
WALL
OPTION

PART NUMBER LOGIC

76155-****

MODULE TYPE
1 = UNGUIDED, TIN

OF COLUMNS
1 = 10 COL
3 = 6 COL
6 = 16 COL
8 = 8 COL

PIN LENGTH (P)
3 = 4.50 (SHORT COMPLIANT, 0.46±0.05 PTH)
4 = 4.90 (SHORT COMPLIANT, 0.46±0.05 PTH)
5 = 5.50 (SHORT COMPLIANT, 0.46±0.05 PTH)
6 = 4.50 (MICRO COMPLIANT, 0.39±0.05 PTH)
7 = 4.90 (MICRO COMPLIANT, 0.39±0.05 PTH)
8 = 5.50 (MICRO COMPLIANT, 0.39±0.05 PTH)

END WALL OPTIONS
0 = OPEN ENDS
1 = LEFT END WALL
2 = DUAL END WALL
3 = RIGHT END WALL

REV	DESCRIPTION	DATE
1	SEE SHEET 1	2012/11/28
2	EC NO: UCP2015-2078	2012/11/28
3	DRW: TIBARRA	2012/11/28
4	CHKD: B INGHAM	2012/11/28
5	APPR: S MILLER	2012/11/28

QUALITY SYMBOLS	GENERAL TOLERANCES (UNLESS SPECIFIED)	
	mm	INCH
▽=0	4 PLACES ±---	±---
▽=0	3 PLACES ±---	±---
▽=0	2 PLACES ±0.13	±---
▽=0	1 PLACE ±0.25	±---
▽=0	0 PLACE ±	±

DIMENSION STYLE		SCALE	DESIGN UNITS	THIRD ANGLE PROJECTION
MM ONLY		2.5:1	METRIC	

DRAWN BY	DATE	TITLE
MSANDBERG	2007/19/07	IMPACT 4 PAIR HEADER UNGUIDED ASSEMBLY SALES DRAWING
CHECKED BY	DATE	
JLAURX	2007/19/07	
APPROVED BY	DATE	
JLAURX	2010/11/15	



ANGULAR	MATERIAL NO.	DOCUMENT NO.	SHEET NO.
±1/2°	SEE TABLE	SD-76155-001	2 OF 3

J
I
H
G
F
E
D
C
B
A

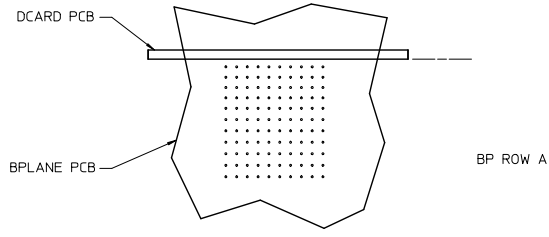

IMPACT 4 PAIR
BOARD RELATIONSHIPS

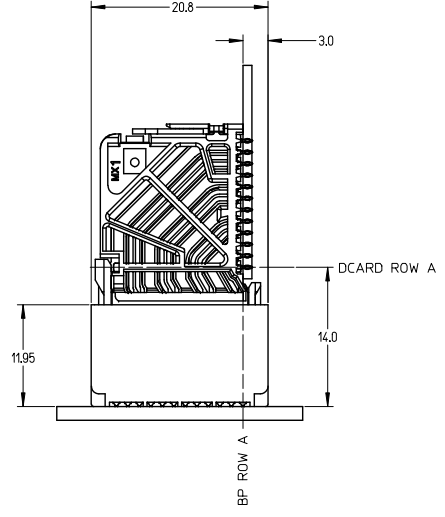
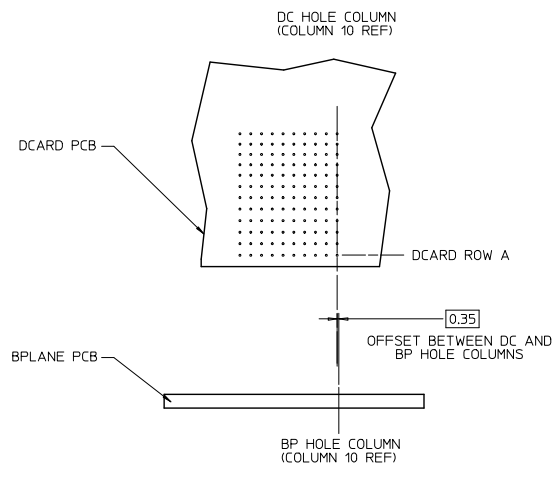

SEE SHEET 1 EC NO: UCP2015-2078 DRAWN BY: DRWNET IBARRA 2012/11/26 CHKD: JB INGHAM 2012/12/18 APPR: SMILLER 2012/12/31	QUALITY SYMBOLS ∇=0 ∇=0 ∇=0	GENERAL TOLERANCES (UNLESS SPECIFIED)		DIMENSION STYLE MM ONLY		SCALE 3:1	DESIGN UNITS METRIC	THIRD ANGLE PROJECTION	
		4 PLACES ± --- ± --- 3 PLACES ± --- ± --- 2 PLACES ± 0.13 ± --- 1 PLACE ± 0.25 ± --- 0 PLACE ± ±		DRAWN BY: MSANDBERG DATE: 2007/19/07 CHECKED BY: JLAURX DATE: 2007/19/07 APPROVED BY: JLAURX DATE: 2010/11/15		TITLE IMPACT 4 PAIR HEADER UNGUIDED ASSEMBLY SALES DRAWING			
		ANGULAR ± 1/2° DRAFT WHERE APPLICABLE MUST REMAIN WITHIN DIMENSIONS		MATERIAL NO. SEE TABLE		DOCUMENT NO. SD-76155-001		SHEET NO. 3 OF 3	
		THIS DRAWING CONTAINS INFORMATION THAT IS PROPRIETARY TO MOLEX INCORPORATED AND SHOULD NOT BE USED WITHOUT WRITTEN PERMISSION							