

Excellent Integrated System Limited

Stocking Distributor

Click to view price, real time Inventory, Delivery & Lifecycle Information:

[Molex Connector Corporation](#)
[0761552603](#)

For any questions, you can email us directly:

sales@integrated-circuit.com

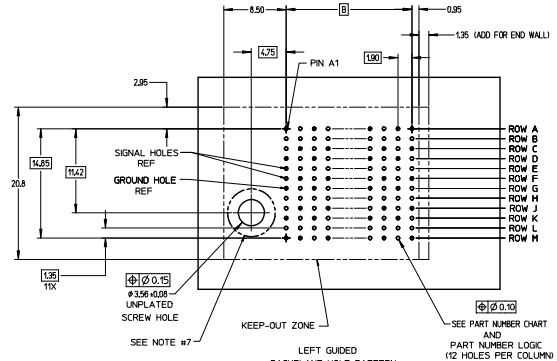
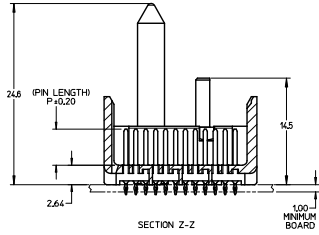
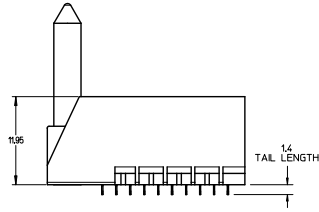
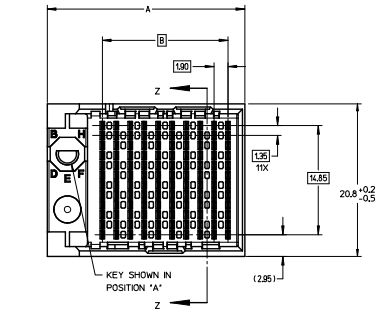

- NOTES:
- MATERIALS: HOUSING - LIQUID CRYSTAL POLYMER (LCP) GLASS-FILLED, UL94V-0
TERMINALS - HIGH PERFORMANCE COPPER ALLOY
Pd-Ni IN CONTACT AREA. SELECTIVE TIN ON PCB TAILS. NICKEL OVERALL.
 - FINISH 5 MICRONCH MINIMUM GOLD FLASH OVER 20 MICRONCH MINIMUM Pd-Ni IN CONTACT AREA. SELECTIVE TIN ON PCB TAILS. NICKEL OVERALL.
 - REFER TO MOLEX PRODUCT SPECIFICATION PS-76060-999 FOR PERFORMANCE SPECIFICATIONS AND ADDITIONAL PCB INFORMATION.
 - THIS PART CONFORMS TO CLASS B REQUIREMENTS OF MOLEX COSMETIC SPEC PS-45499-002.
 - PACKAGE PER PK-70873-757.
 - SEE SHEETS 2 & 3 FOR PART NUMBERS AND BOARD RELATIONSHIPS.
 - FOR GROUNDED GUIDE PINS USE DIA. 3.56 +/-0.08 (PTH) DIA. 3.66 (DRILL) AND DIA. 6.5 (PAD).
 - MATES WITH IMPACT DC SERIES NO. 76160.
 - KEEP OUT ZONE FOR BP HOUSING LENGTH INCLUDES AN ADDITIONAL 1.0MM TO ACCOMMODATE FOR SPACE REQUIRED BY DC FRONT HOUSING.
 - REFER TO MOLEX PCB ROUTING GUIDE AS-76060-990 FOR ANTI PAD AND ROUTING RECOMMENDATIONS.
 - CONNECTORS SUPPLIED WITH A 2-56 UNC-2A SCREW.
 - THESE DIMENSIONS REPRESENT THE AREA NEEDED TO ACCOMMODATE CONNECTOR INSERTION AND REPAIR ON THE PC BOARD, THIS IS REFERRED TO AS THE "CONNECTOR KEEP OUT ZONE" AND DOES NOT REPRESENT THE ACTUAL PERIMETER OF THE CONNECTOR, WHEN LAYING OUT THE PC BOARD FOR CONNECTORS STACKED TOGETHER, USE A 1.9mm PROGRESSION.

Pd-Ni
PLATING

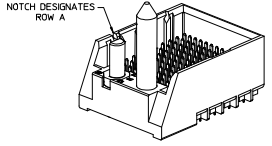

INITIAL RELEASE ECS INC (EPT/04-2332) DRN/SVANG01 2015/12/08 CHK/OMW/LE 2015/12/08 APP/SHILLER 2015/12/17 REV	QUALITY SYMBOLS	GENERAL TOLERANCES (UNLESS SPECIFIED):	DIMENSION STYLE	SCALE	DESIGN UNITS	THIRD ANGLE PROJECTION
	$\nabla=0$ 4 PLACES ± --- mm ± --- INCH $\nabla=0$ 3 PLACES ± --- mm ± --- INCH $\nabla=0$ 2 PLACES ± 0.13 mm ± --- INCH $\nabla=0$ 1 PLACE ± 0.25 mm ± --- INCH $\nabla=0$ 0 PLACE ± --- mm ± --- INCH	(UNLESS SPECIFIED) MM ONLY 4:1 METRIC THIRD ANGLE PROJECTION	DRAWN BY SVANG01 DATE 2015/12/08 CHECKED BY MWOLFE DATE 2015/12/08 APPROVED BY SMILLER DATE 2015/12/17 MATERIAL NO. SEE TABLE ANGLUAR ±1/2° DRAFT WHERE APPLICABLE MUST REMAIN WITHIN DIMENSIONS SIZE D THIS DRAWING CONTAINS INFORMATION THAT IS PROPRIETARY TO MOLEX INCORPORATED AND SHOULD NOT BE USED WITHOUT WRITTEN PERMISSION	TITLE IMPACT 4 PAIR HEADER LEFT GUIDED PDNI ASSEMBLY SALES DRAWING	DOCUMENT NO. RSD-173428-002	SHEET NO. 1 OF 3

PART NUMBER TABLE

MATERIAL NUMBER	# OF COLUMNS	# OF DIFF PAIR	DIM 'A'	DIM 'B'	GUIDE LEFT END WALL OPTION
173428- *3**	6	24	19.3	9.50	
173428- *8**	8	32	23.1	13.30	
173428- *1**	10	40	26.9	17.10	
173428- *6**	16	64	38.3	28.50	

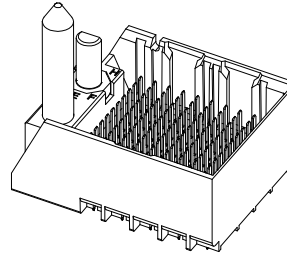

GUIDE LEFT
END WALL
OPTION

MATERIAL NUMBER	# OF COLUMNS	# OF DIFF PAIR	DIM 'A'	DIM 'B'	GUIDE LEFT OPEN WALL OPTION
173428- *3**	6	24	17.9	9.50	
173428- *8**	8	32	21.7	13.30	
173428- *1**	10	40	25.5	17.10	
173428- *6**	16	64	36.9	28.50	

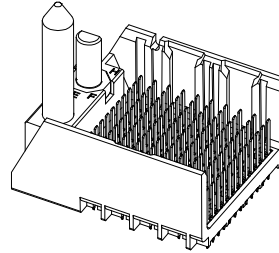

GUIDE LEFT
OPEN WALL
OPTION

PART NUMBER LOGIC

173428-****

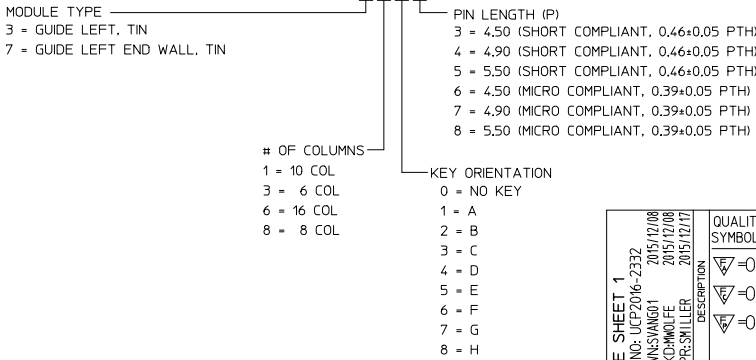

SEE SHEET 1 EC NO: UCP2016-2332 DRWNSVANG01 2015/12/08 CHKDWOLFE 2015/12/08 APPRSMILLER 2015/12/17 REV A	QUALITY SYMBOLS ∇=0 ∇=0 ∇=0	GENERAL TOLERANCES (UNLESS SPECIFIED)		DIMENSION STYLE MM ONLY		SCALE 3:1	DESIGN UNITS METRIC	THIRD ANGLE PROJECTION	
		4 PLACES ± --- ± ---	3 PLACES ± --- ± ---	DRAWN BY SVANG01	DATE 2015/12/08	TITLE IMPACT 4 PAIR HEADER LEFT GUIDED PDNI ASSEMBLY SALES DRAWING			
		2 PLACES ± 0.13 ± ---	1 PLACE ± 0.25 ± ---	CHECKED BY MWOLFE	DATE 2015/12/08				
		ANGULAR ± 1/2°		APPROVED BY SMILLER	DATE 2015/12/17				
		DRAFT WHERE APPLICABLE MUST REMAIN WITHIN DIMENSIONS		SEE TABLE		MATERIAL NO.	DOCUMENT NO. RSD-173428-002	SHEET NO. 2 OF 3	

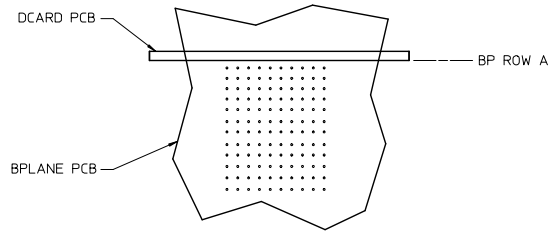

IMPACT 4 PAIR BOARD RELATIONSHIPS

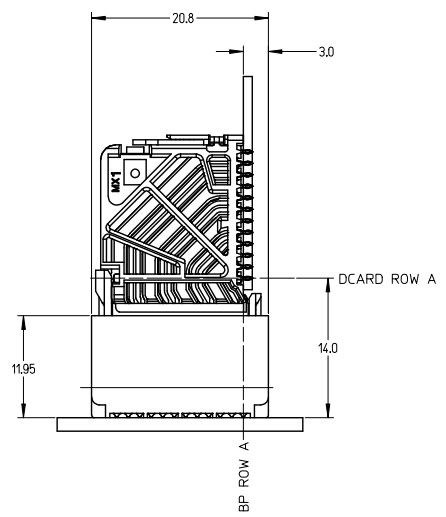
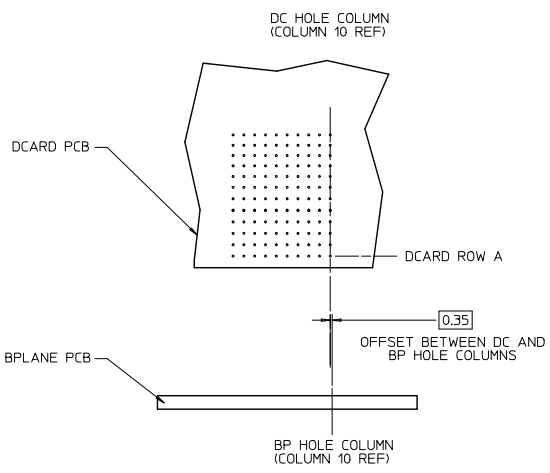

SEE SHEET 1 EC NO: UCP2016-2332 DRWNG: SVANG01 CHK: KMOLFE APPR: SMILLER	2015/12/08 2015/12/08 2015/12/17	QUALITY SYMBOLS ∇=0 ∇=0 ∇=0	GENERAL TOLERANCES (UNLESS SPECIFIED)		DIMENSION STYLE MM ONLY		SCALE 2:1	DESIGN UNITS METRIC	THIRD ANGLE PROJECTION		
				mm	INCH	DRAWN BY SVANG01	DATE 2015/12/08	TITLE IMPACT 4 PAIR HEADER LEFT GUIDED PDNI ASSEMBLY SALES DRAWING molex MATERIAL NO. RSD-173428-002 DOCUMENT NO. RSD-173428-002 SHEET NO. 3 OF 3			
			4 PLACES ±	---	---	CHECKED BY MWOLFE	DATE 2015/12/08				
			3 PLACES ±	---	---	APPROVED BY SMILLER	DATE 2015/12/17				
2 PLACES ±	0.13	---									
1 PLACE ±	0.25	---			ANGULAR ±1/2°						
0 PLACE ±		---			DRAFT WHERE APPLICABLE MUST REMAIN WITHIN DIMENSIONS		SEE TABLE				

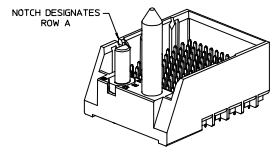
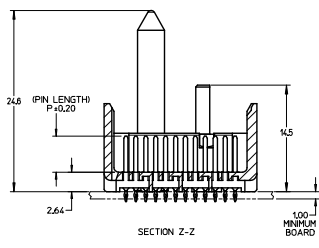
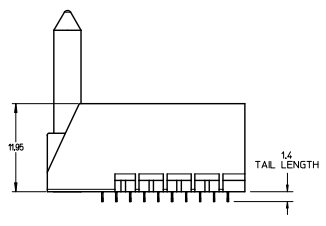
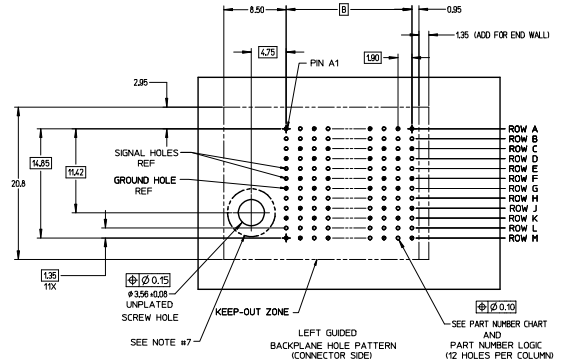
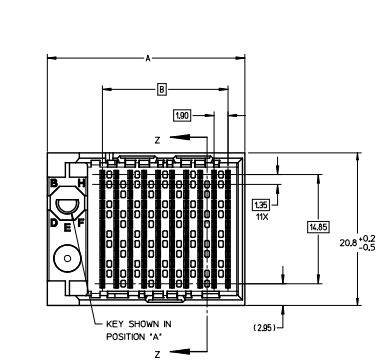

- NOTES:**
- MATERIALS: HOUSING - LIQUID CRYSTAL POLYMER (LCP) GLASS-FILLED, UL94V-0
TERMINALS - HIGH PERFORMANCE COPPER ALLOY
 - FINISH: 30μM MIN GOLD IN CONTACT AREA, SELECTIVE TIN ON PCB TAILS, NICKEL OVERALL.
 - REFER TO MOLEX PRODUCT SPECIFICATION PS-76060-999 FOR PERFORMANCE SPECIFICATIONS AND ADDITIONAL PCB INFORMATION.
 - THIS PART CONFORMS TO CLASS B REQUIREMENTS OF MOLEX COSMETIC SPEC PS-45499-002.
 - PACKAGE PER: PK-70873-757.
 - SEE SHEETS 2 & 3 FOR PART NUMBERS AND BOARD RELATIONSHIPS.
 - FOR GROUNDED GUIDE PINS USE DIA. 3.56 (+/-0.08 IPTH) DIA. 3.66 (DRILL) AND DIA. 6.5 (PAD).
 - MATES WITH IMPACT DC SERIES NO. 76160.
 - KEEP OUT ZONE FOR BP HOUSING LENGTH INCLUDES AN ADDITIONAL 1.0MM TO ACCOMMODATE FOR SPACE REQUIRED BY DC FRONT HOUSING.
 - REFER TO MOLEX PCB ROUTING GUIDE AS-76060-990 FOR ANTI PAD AND ROUTING RECOMMENDATIONS.
 - CONNECTORS SUPPLIED WITH A 2-56 UNC-2A SCREW.
 - THESE DIMENSIONS REPRESENT THE AREA NEEDED TO ACCOMMODATE CONNECTOR INSERTION AND REPAIR ON THE PCB BOARD. THIS IS REFERRED TO AS THE 'CONNECTOR KEEP OUT ZONE' AND DOES NOT REPRESENT THE ACTUAL PERIMETER OF THE CONNECTOR. WHEN LAYING OUT THE PCB BOARD FOR CONNECTORS STACKED TOGETHER, USE A 1.5mm PROGRESSION.

CONVERT TO LEAD FREE EC NSC IEP2003-2078 DRAWN BY BARBA 20/12/08 CHECKED INHAR 20/12/08 APPROVED BY JLAUR 20/12/08 (REV)	QUALITY SYMBOLS 4 PLACES ±0 3 PLACES ±0 2 PLACES ±0.13 1 PLACE ±0.25 0 PLACE ±	GENERAL TOLERANCES (UNLESS SPECIFIED): mm INCH ±0.15 ±0.005 ±0.25 ±0.010 ±0.50 ±0.020 ±0.75 ±0.030 ±1.00 ±0.040 ±1.50 ±0.060 ±2.00 ±0.080 ±3.00 ±0.120 ±4.00 ±0.160 ±5.00 ±0.200 ±6.00 ±0.240 ±8.00 ±0.320 ±10.00 ±0.400 ±15.00 ±0.600 ±20.00 ±0.800 ±30.00 ±1.200 ±40.00 ±1.600 ±50.00 ±2.000 ±60.00 ±2.400 ±80.00 ±3.200 ±100.00 ±4.000	DIMENSION STYLE MM ONLY	SCALE 4:1	DESIGN UNITS METRIC	THIRD ANGLE PROJECTION	
	DATE 2010/11/15	TITLE IMPACT 4 PAIR HEADER LEFT GUIDED ASSEMBLY SALES DRAWING	DRAWN BY MSANBERG	DATE 2007/19/07	CHECKED BY JLAUR	DATE 2007/19/07	APPROVED BY JLAUR
ANGULAR ±1/2°	DRAFT WHERE APPLICABLE MUST REMAIN WITHIN DIMENSIONS	SEE TABLE	MATERIAL NR. SEE TABLE	SIZE D	THIS DRAWING CONTAINS INFORMATION THAT IS PROPRIETARY TO MOLEX INCORPORATED AND SHOULD NOT BE USED WITHOUT WRITTEN PERMISSION	DOCUMENT NO. SD-76155-002	SHEET NO. 1 OF 3

PART NUMBER TABLE

MATERIAL NUMBER	# OF COLUMNS	# OF DIFF PAIR	DIM 'A'	DIM 'B'	GUIDE LEFT END WALL OPTION
76155-3**	6	24	19.3	9.50	
76155-8**	8	32	23.1	13.30	
76155-1**	10	40	26.9	17.10	
76155-6**	16	64	38.3	28.50	

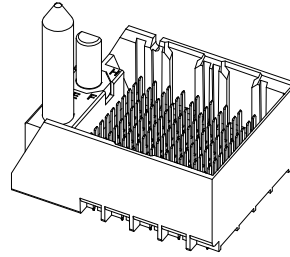

GUIDE LEFT
END WALL
OPTION

MATERIAL NUMBER	# OF COLUMNS	# OF DIFF PAIR	DIM 'A'	DIM 'B'	GUIDE LEFT OPEN WALL OPTION
76155-3**	6	24	17.9	9.50	
76155-8**	8	32	21.7	13.30	
76155-1**	10	40	25.5	17.10	
76155-6**	16	64	36.9	28.50	

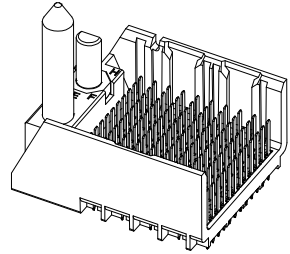

GUIDE LEFT
OPEN WALL
OPTION

PART NUMBER LOGIC

76155-****

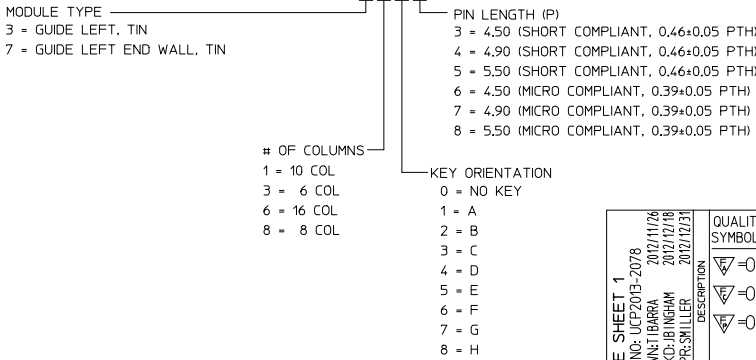

SEE SHEET 1 EC NO: UCP2015-2078 DRAWN: TIBARRA 2012/11/28 CHKD: BINGHAM 2012/12/18 APPR: SMILLER 2012/12/31	QUALITY SYMBOLS ∇=0 ∇=0 ∇=0	GENERAL TOLERANCES (UNLESS SPECIFIED)		DIMENSION STYLE MM ONLY		SCALE 3:1	DESIGN UNITS METRIC	THIRD ANGLE PROJECTION	
		4 PLACES ± --- ± ---	3 PLACES ± --- ± ---	2 PLACES ± 0.13 ± ---	1 PLACE ± 0.25 ± ---	0 PLACE ± ±	DRAWN BY: MSANDBERG DATE: 2007/19/07 CHECKED BY: JLAURX DATE: 2007/19/07 APPROVED BY: JLAURX DATE: 2010/11/15		TITLE IMPACT 4 PAIR HEADER LEFT GUIDED ASSEMBLY SALES DRAWING
		ANGULAR ±1/2°		MATERIAL NO.		DOCUMENT NO.		SHEET NO.	
		DRAFT WHERE APPLICABLE MUST REMAIN WITHIN DIMENSIONS		SEE TABLE		SD-76155-002		2 OF 3	
THIS DRAWING CONTAINS INFORMATION THAT IS PROPRIETARY TO MOLEX INCORPORATED AND SHOULD NOT BE USED WITHOUT WRITTEN PERMISSION									

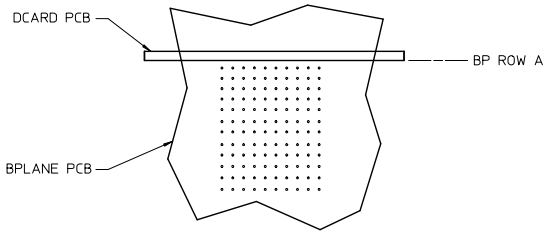

IMPACT 4 PAIR
BOARD RELATIONSHIPS

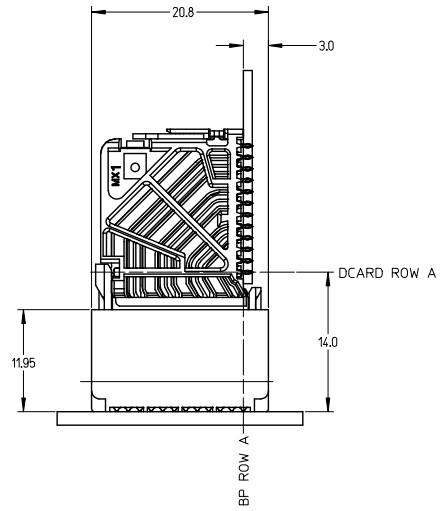
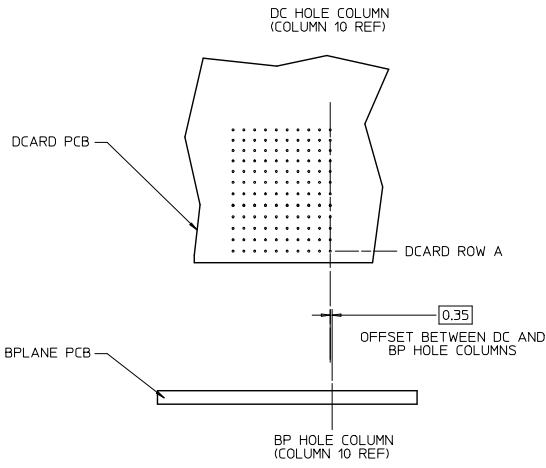

SEE SHEET 1 EC NO: UCP2013-2078 DRAWN: IBARRA 2012/11/28 CHKD: B INGHAM 2012/12/18 APPR: MILLER 2012/12/31	QUALITY SYMBOLS ∇=0 ∇=0 ∇=0	GENERAL TOLERANCES (UNLESS SPECIFIED)		DIMENSION STYLE MM ONLY		SCALE 2:1	DESIGN UNITS METRIC	THIRD ANGLE PROJECTION	
			mm	INCH	DRAWN BY MSANDBERG	DATE 2007/19/07	TITLE IMPACT 4 PAIR HEADER LEFT GUIDED ASSEMBLY SALES DRAWING molex DOCUMENT NO. SD-76155-002 SHEET NO. 3 OF 3		
		4 PLACES ±	---	---	CHECKED BY JLAURX	DATE 2007/19/07			
		3 PLACES ±	---	---	APPROVED BY JLAURX	DATE 2010/11/15			
2 PLACES ±	0.13	---							
1 PLACE ±	0.25	---							
0 PLACE ±									
		ANGULAR ±1/2°		MATERIAL NO.		DOCUMENT NO.		SHEET NO.	
		DRAFT WHERE APPLICABLE MUST REMAIN WITHIN DIMENSIONS		SEE TABLE		SD-76155-002		3 OF 3	
				SIZE C		THIS DRAWING CONTAINS INFORMATION THAT IS PROPRIETARY TO MOLEX INCORPORATED AND SHOULD NOT BE USED WITHOUT WRITTEN PERMISSION			