

Excellent Integrated System Limited

Stocking Distributor

Click to view price, real time Inventory, Delivery & Lifecycle Information:

[Molex Connector Corporation](#)
[0761658108](#)

For any questions, you can email us directly:

sales@integrated-circuit.com

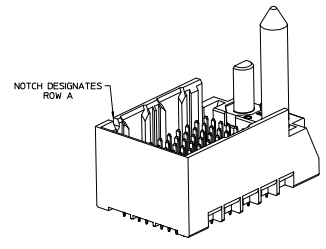
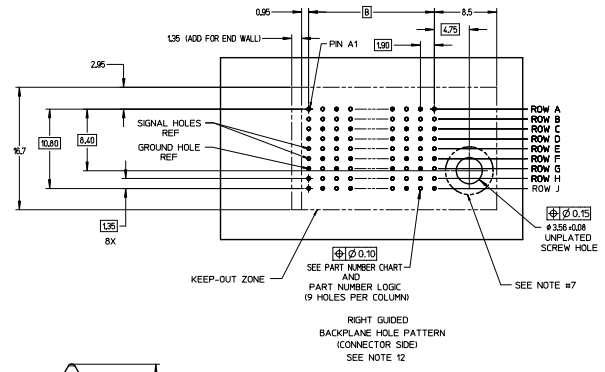
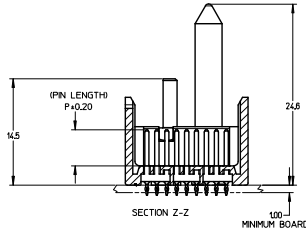
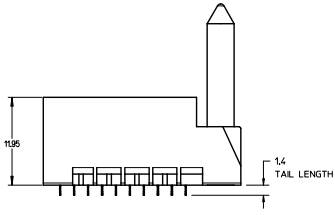
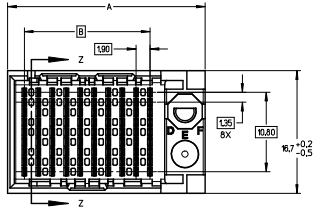

NOTES:

1. MATERIALS: HOUSING - LIQUID CRYSTAL POLYMER (LCP)
GLASS-FILLED, UL94V-0
TERMINALS - HIGH PERFORMANCE COPPER ALLOY
2. FINISH: 30μ MIN GOLD IN CONTACT AREA,
SELECTIVE TIN ON PCB TAILS,
NICKEL OVERALL.
3. REFER TO MOLEX PRODUCT SPECIFICATION PS-76060-999
FOR PERFORMANCE SPECIFICATIONS AND ADDITIONAL PCB INFORMATION.
4. THIS PART CONFORMS TO CLASS B REQUIREMENTS OF
MOLEX COSMETIC SPEC PS-45499-002.
5. PACKAGE PER: PK-70873-758.
6. SEE SHEETS 2 & 3 FOR PART NUMBERS AND BOARD RELATIONSHIPS.
7. FOR GROUNDED GUIDE PINS USE DIA. 3.56 +/-0.08 (PTH)
DIA. 3.66 (DRILL) AND DIA. 4.5 (PAD).
8. MATES WITH IMPACT DC SERIES NO. 76170.
9. KEEP OUT ZONE FOR BP HOUSING LENGTH INCLUDES AN ADDITIONAL 10MM
TO ACCOMMODATE FOR SPACE REQUIRED BY DC FRONT HOUSING.
10. REFER TO MOLEX PCB ROUTING GUIDE AS-76060-990 FOR ANTI-PAD AND ROUTING RECOMMENDATIONS.
11. CONNECTORS SUPPLIED WITH A 2-56 UNC-2A SCREW.
12. THESE DIMENSIONS REPRESENT THE AREA NEEDED TO ACCOMMODATE CONNECTOR INSERTION AND
REPAIR ON THE PC BOARD. THIS IS REFERRED TO AS THE "CONNECTOR KEEP OUT ZONE" AND
DOES NOT REPRESENT THE ACTUAL PERIMETER OF THE CONNECTOR, WHEN LAYING OUT A PC BOARD
FOR CONNECTORS STACKED TOGETHER, USE A 1.9mm PROGRESSION.

REVISED (NUMBER) EC NO. UEP2014-0987 2013/08/25 CHENG JIN HAN 2013/08/25 APPROVAL (DATE) J1 2013/09/25 (BY)	QUALITY SYMBOLS 4 PLACES ±0 3 PLACES ±0 2 PLACES ±0.13 1 PLACE ±0.25 0 PLACE ±	GENERAL TOLERANCES (UNLESS SPECIFIED) mm INCH ±0.15 ±0.005 ±0.25 ±0.010 ±0.50 ±0.020 ±1.00 ±0.040 ±1.50 ±0.060 ±2.00 ±0.080 ±3.00 ±0.120 ±4.00 ±0.160 ±5.00 ±0.200 ±6.00 ±0.240 ±8.00 ±0.320 ±10.00 ±0.400 ±15.00 ±0.600 ±20.00 ±0.800 ±30.00 ±1.200 ±40.00 ±1.600 ±50.00 ±2.000 ±60.00 ±2.400 ±80.00 ±3.200 ±100.00 ±4.000	DIMENSION STYLE MM ONLY DRAWN BY MSANDBERG CHECKED BY JL AURX APPROVED BY JL AURX DATE 2007/06/18 DATE 2007/06/18 DATE 2010/10/15	SCALE 4:1 DESIGN UNITS METRIC THIRD ANGLE PROJECTION	TITLE IMPACT BP 3 PAIR RIGHT GUIDED ASSEMBLY SALES DRAWING	MATERIAL NO. SEE TABLE SIZE D THIS DRAWING CONTAINS INFORMATION THAT IS PROPRIETARY TO MOLEX INCORPORATED AND SHOULD NOT BE USED WITHOUT WRITTEN PERMISSION	DOCUMENT NO. SD-76165-003 SHEET NO. 1 OF 3
--	---	--	--	--	--	---	---

PART NUMBER TABLE

MATERIAL NUMBER	# OF COLUMNS	# OF DIFF PAIR	DIM "A"	DIM "B"	GUIDE RIGHT END WALL OPTION
76165-*3**	6	18	19.3	9.50	
76165-*8**	8	24	23.1	13.30	
76165-*1**	10	30	26.9	17.10	
76165-*6**	16	48	38.3	28.50	

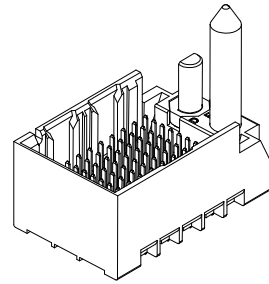

GUIDE RIGHT
END WALL
OPTION

MATERIAL NUMBER	# OF COLUMNS	# OF DIFF PAIR	DIM "A"	DIM "B"	GUIDE RIGHT OPEN WALL OPTION
76165-*3**	6	18	17.9	9.50	
76165-*8**	8	24	21.7	13.30	
76165-*1**	10	30	25.5	17.10	
76165-*6**	16	48	36.9	28.50	

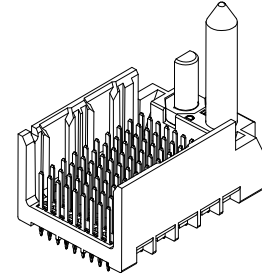

GUIDE RIGHT
OPEN WALL
OPTION

PART NUMBER LOGIC

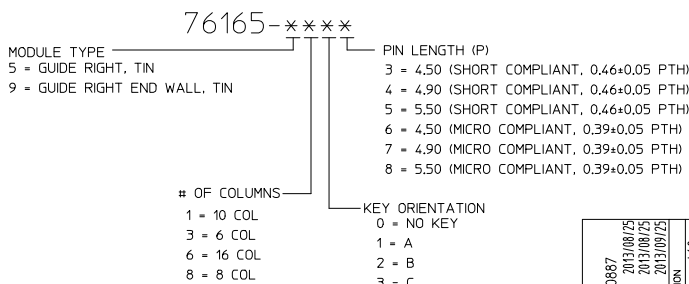

SEE SHEET 1 EC NO: UCP2014-0887 DRWN: BINGHAY 2013/08/29 CHKD: LAURX 2013/08/29 APPR: LAURX 2013/09/25 DESCRIPTION REV	QUALITY SYMBOLS	GENERAL TOLERANCES (UNLESS SPECIFIED)	DIMENSION STYLE MM ONLY	SCALE 3:1	DESIGN UNITS METRIC	THIRD ANGLE PROJECTION
	▽=0	4 PLACES ± --- ± ---	DRAWN BY MSANDBERG	DATE 2007/06/18	TITLE IMPACT BP 3 PAIR RIGHT GUIDED ASSEMBLY SALESS DRAWING	
	▽=0	3 PLACES ± --- ± ---	CHECKED BY JLAURX	DATE 2007/06/18		
	▽=0	2 PLACES ± 0.13 ± ---	APPROVED BY JLAURX	DATE 2010/10/15		
		1 PLACE ± 0.25 ± ---				
		0 PLACE ± ±				
		ANGULAR ±1/2°	MATERIAL NO.	DOCUMENT NO.	SHEET NO.	
		DRAFT WHERE APPLICABLE MUST REMAIN WITHIN DIMENSIONS	SEE TABLE	SD-76165-003	2 OF 3	
			THIS DRAWING CONTAINS INFORMATION THAT IS PROPRIETARY TO MOLEX INCORPORATED AND SHOULD NOT BE USED WITHOUT WRITTEN PERMISSION			

IMPACT 3 PAIR
BOARD RELATIONSHIPS

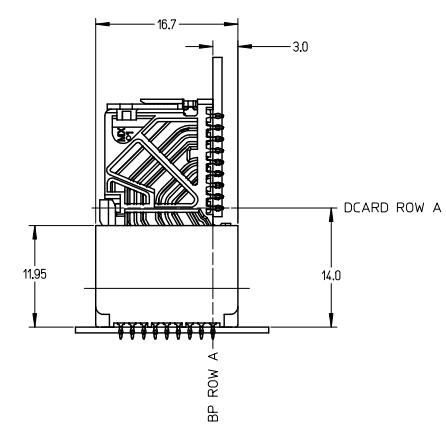
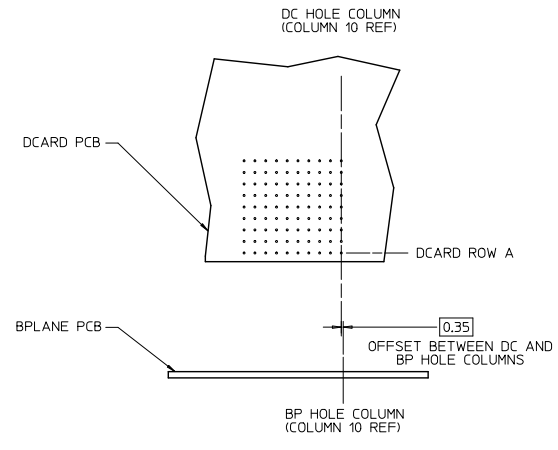
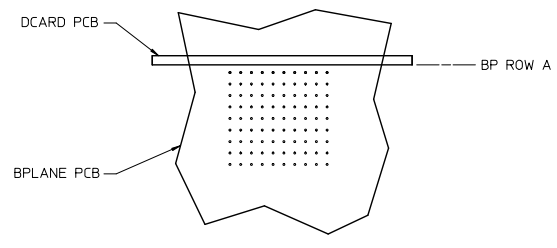

SEE SHEET 1 EC NO: UCP2014-0887 DRAWN: B INGRAM 2013/08/29 CHKD: JLAURX 2013/08/29 APPR: JLAURX 2013/09/25	QUALITY SYMBOLS ∇=0 ∇=0 ∇=0	GENERAL TOLERANCES (UNLESS SPECIFIED)		DIMENSION STYLE MM ONLY		SCALE 2:1	DESIGN UNITS METRIC	THIRD ANGLE PROJECTION	
		4 PLACES ± --- ± --- 3 PLACES ± --- ± --- 2 PLACES ± 0.13 ± --- 1 PLACE ± 0.25 ± --- 0 PLACE ± ±	mm INCH --- --- --- --- --- --- --- --- --- ---	DRAWN BY MSANDBERG	DATE 2007/06/18	TITLE IMPACT BP 3 PAIR RIGHT GUIDED ASSEMBLY SALESS DRAWING		molex	
J1	REV	DRAFT WHERE APPLICABLE MUST REMAIN WITHIN DIMENSIONS		MATERIAL NO. SEE TABLE		DOCUMENT NO. SD-76165-003		THIS DRAWING CONTAINS INFORMATION THAT IS PROPRIETARY TO MOLEX INCORPORATED AND SHOULD NOT BE USED WITHOUT WRITTEN PERMISSION	