



Distributor of CTS Electronic Components: Excellent Integrated System Limited
Datasheet of TF202P32K7680 - Crystal 32.7680kHz 20ppm 12.5pF 90 kOhm -40°C - 85°C
Surface Mount 2-SMD

Contact us: sales@integrated-circuit.com Website: www.integrated-circuit.com

Excellent Integrated System Limited

Stocking Distributor

Click to view price, real time Inventory, Delivery & Lifecycle Information:

[CTS Electronic Components](#)
[TF202P32K7680](#)

For any questions, you can email us directly:

sales@integrated-circuit.com



TF20 SERIES TUNING FORK CRYSTAL



FEATURES

- 32.7680 kHz Frequency Reference
- Package Size 2.0mm x 1.2mm
- Tuning Fork Crystal Design
- Hermetic Ceramic Package
- Frequency Tolerance, ± 20 ppm Standard
 [± 10 ppm, ± 30 ppm and ± 50 ppm available]
- Frequency Temperature Coefficient, -0.030 ppm/ $^{\circ}\text{C}^2$
- Operating Temperature, -40°C to $+85^{\circ}\text{C}$ Standard
- Tape & Reel Packaging, EAI-481-2
- **RoHS/Green Compliant (6/6)**

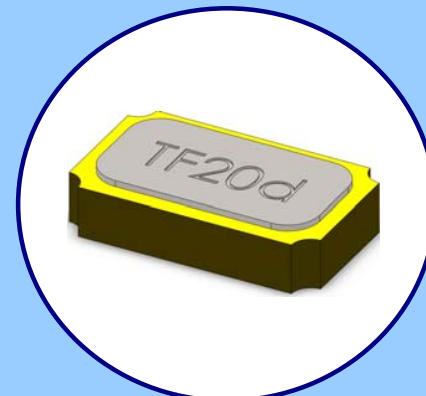

APPLICATIONS

The TF20 crystal series is ideal for use in a wide range of communication equipment, notebooks, computer peripherals, audio visual, Bluetooth and other wireless applications, USB interfaces, PDAs and automotive electronics.

ORDERING INFORMATION

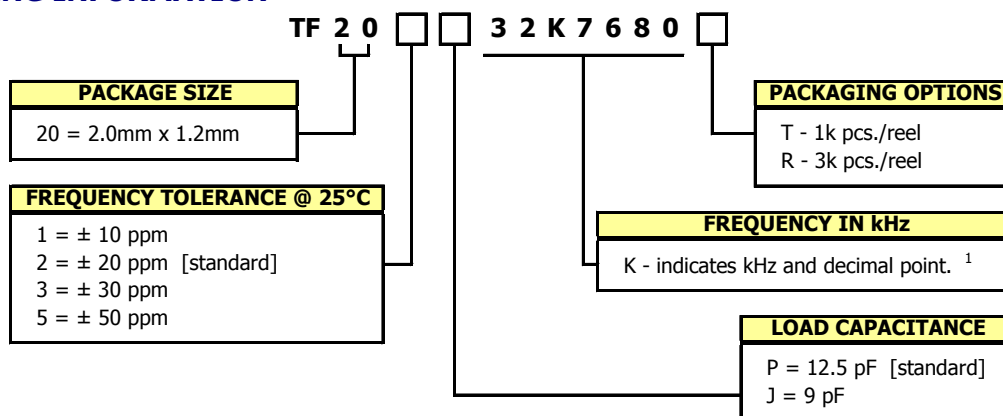

1] Frequency is recorded with two leading digits before the 'K' and 4 significant digits after the 'K' (including zeros).

**Not all performance combinations and frequencies may be available.
 Contact your local CTS Representative or CTS Customer Service for availability.**

PACKAGING INFORMATION [reference]

Factory may package reels in quantities of 1k pcs. or 3k pcs. Reel size is 180mm.
 DIMENSIONS IN MILLIMETERS

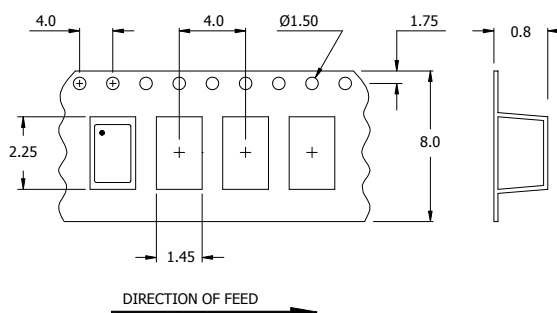

ELECTRICAL CHARACTERISTICS

	PARAMETER	SYMBOL	CONDITIONS	MIN	TYP	MAX	UNIT
ELECTRICAL PARAMETERS	Frequency	f_0			32.7680		kHz
	Operating Mode	-		Flexural Mode [Tuning Fork]			-
	Frequency Tolerance *	$\Delta f/f_0$	@+25°C	-	20	-	± ppm
	Frequency Temperature Coefficient	$\Delta f/f_M$		-0.030 ±0.01ppm/°C ²			-
	Frequency Stability			See Figure 1			
	Operating Temperature Range	T_A		-40	-	+85	°C
	Turnover Temperature	T_M	±5°C	-	+25	-	°C
	Load Capacitance *	C_L	Standard	-	12.5	-	pF
	Aging	$\Delta f/f_0$	@+25°C, 1st year	-	-	3.0	± ppm
	Drive Level	DL		-	0.1	0.5	µW
	Shunt Capacitance	C_0	@1 MHz	-	-	7.0	pF
	Motional Capacitance	C_1		-	7.0	-	fF
	Series Resistance	R_1		-	-	90	k Ohms
	Insulation Resistance	R_i	+100Vdc ±15Vdc	500	-	-	M Ohms
	Storage Temperature Range	T_{STR}		-55	-	+125	°C

* See Ordering Information for available options.

FIGURE 1

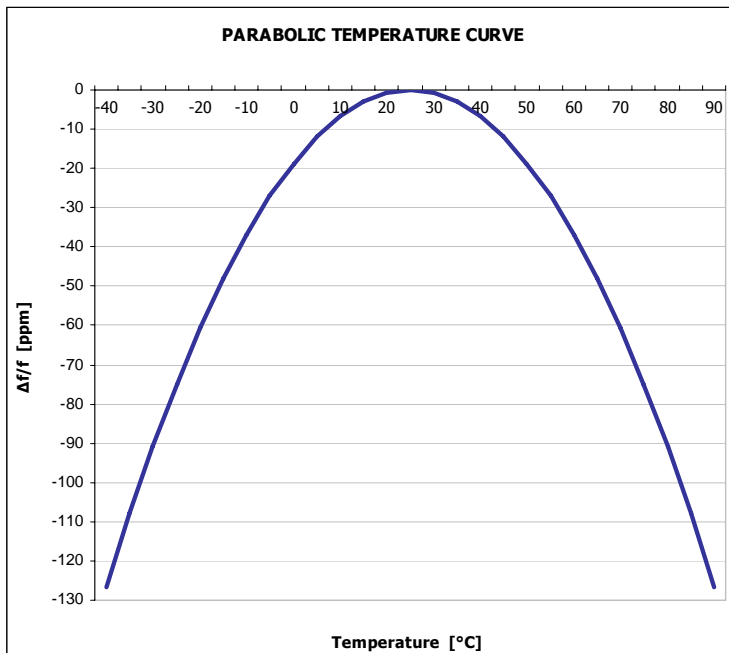

Frequency stability [ppm] is determined using parabolic curve, $\Delta f = \text{Temperature Coefficient}(T_A - T_M)^2$.

Ex. Find frequency stability at $T_A = 45^\circ\text{C}$
 $\Delta f = -0.030(45-25)^2$
 $\Delta f = -0.030(20)^2$
 $\Delta f = -12.0 \text{ ppm}$

MECHANICAL SPECIFICATIONS

TF20 PACKAGE DRAWING

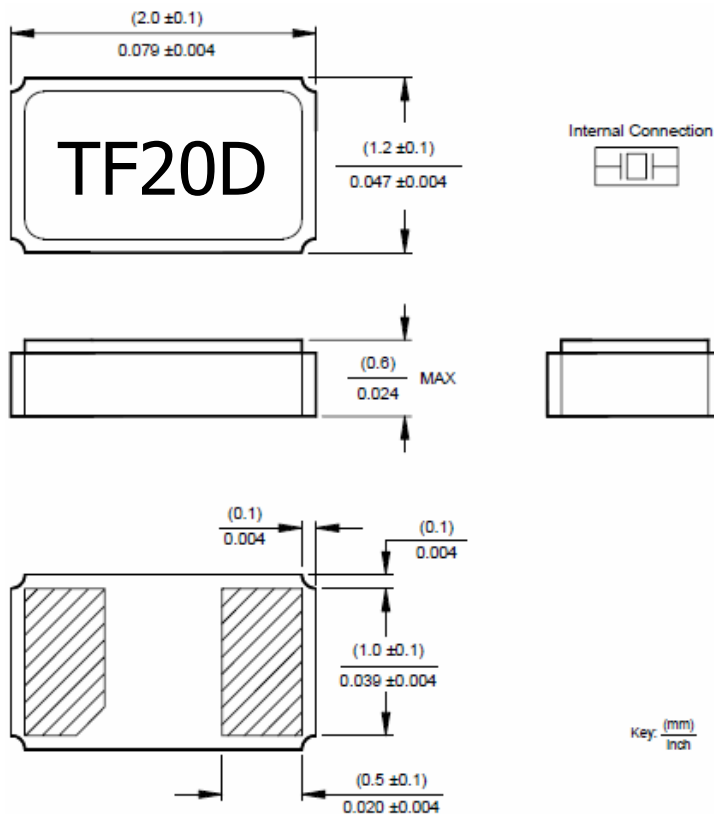

MARKING INFORMATION

1. TF20 - CTS Model Series.
2. D - Date code. See Table I for codes.

TABLE I - DATE CODE

YEAR		MONTH														
		JAN	FEB	MAR	APR	MAY	JUN	JUL	AUG	SEP	OCT	NOV	DEC			
2001	2005	2009	2013	2017	A	B	C	D	E	F	G	H	J	K	L	M
2002	2006	2010	2014	2018	N	P	Q	R	S	T	U	V	W	X	Y	Z
2003	2007	2011	2015	2019	a	b	c	d	e	f	g	h	j	k	l	m
2004	2008	2012	2016	2020	n	p	q	r	s	t	u	v	w	x	y	z

SUGGESTED SOLDER PAD GEOMETRY

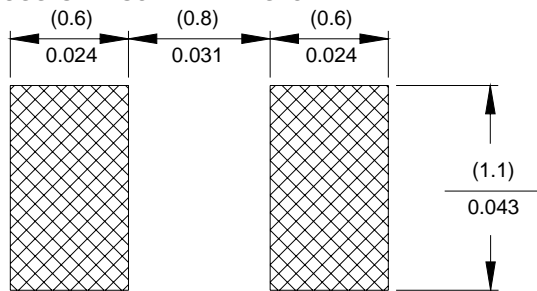

NOTES

1. Complete CTS part number, frequency value, date code and manufacturing site code information must appear on reel and carton labels.
2. Termination pads (e4); barrier plating is nickel [Ni] with gold [Au] flash plate.
3. Reflow conditions per JEDEC J-STD-020; 260°C maximum, 20 seconds.
4. MSL = 1.