

Excellent Integrated System Limited

Stocking Distributor

Click to view price, real time Inventory, Delivery & Lifecycle Information:

[Panasonic Electronic Components](#)
[LN21CALURS](#)

For any questions, you can email us directly:

sales@integrated-circuit.com

Ultra Bright GaAlAs Lamps



**Round Type
φ5.0mm Series**

Type No. Lighting Color
 LN21CAL(UQS) Red

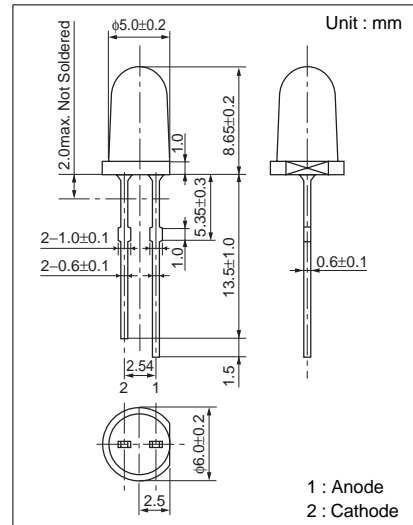

Absolute Maximum Ratings (Ta=25°C)

Lighting Color	P _D (mW)	I _F (mA)	I _{FP} (mA)*	V _R (V)	T _{opr} (°C)	T _{stg} (°C)
Red	70	30	150	3	-25 ~ +85	-30 ~ +100

* The condition of I_{FP} is duty 10%, Pulse width 1 msec

Electro-Optical Characteristics (Ta=25°C)

Type No.	Lighting Color	Lens Color	I _O		I _F	V _F		λP	Δλ	I _F	I _R	
			typ	min		typ	max	typ	typ		max	V _R
LN21CAL(UQS)	Red	Clear	1500	1000	20	1.8	2.4	660	20	20	100	3
Unit	—	—	mcd	mcd	mA	V	V	nm	nm	mA	μA	V

