

## Excellent Integrated System Limited

Stocking Distributor

Click to view price, real time Inventory, Delivery & Lifecycle Information:

[STMicroelectronics](#)

[STL66DN3LLH5](#)

For any questions, you can email us directly:

[sales@integrated-circuit.com](mailto:sales@integrated-circuit.com)



# STL66DN3LLH5

Dual N-channel 30 V, 5.9 mΩ, 20 A STripFET™ V Power MOSFET in PowerFLAT™ 5x6 double island package

Datasheet — production data

## Features

Type	V <sub>DSS</sub>	R <sub>DS(on) max</sub>	I <sub>D</sub>
STL66DN3LLH5	30 V	< 6.5 mΩ	20 A <sup>(1)</sup>

1. The value is rated according R<sub>thj-pcb</sub>

- Logic level V<sub>GS(th)</sub>
- 175 °C junction temperature

## Applications

- Switching applications
- Automotive

## Description

This device is an N-channel Power MOSFET developed using STMicroelectronics' STripFET™V technology. The device has been optimized to achieve very low on-state resistance, contributing to an FOM that is among the best in its class.



Figure 1. Internal schematic diagram

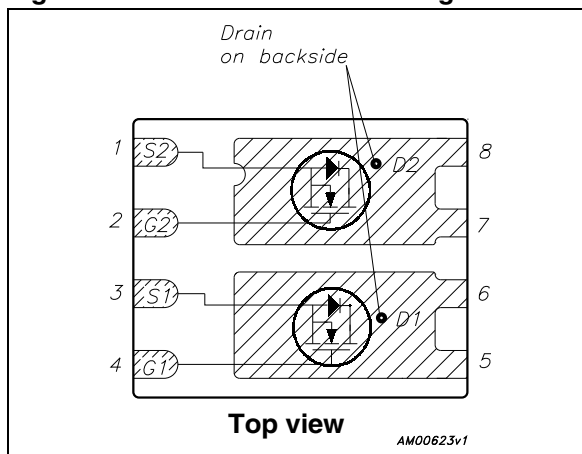

Table 1. Device summary

Order code	Marking	Package	Packaging
STL66DN3LLH5	66DN3LLH5	PowerFLAT™ 5x6 double island	Tape and reel

---

## Contents

<b>1</b>	<b>Electrical ratings</b> .....	<b>3</b>
<b>2</b>	<b>Electrical characteristics</b> .....	<b>4</b>
2.1	Electrical characteristics (curves) .....	6
<b>3</b>	<b>Test circuits</b> .....	<b>8</b>
<b>4</b>	<b>Package mechanical data</b> .....	<b>9</b>
<b>5</b>	<b>Packaging mechanical data</b> .....	<b>12</b>
<b>6</b>	<b>Revision history</b> .....	<b>14</b>

# 1 Electrical ratings

**Table 2. Absolute maximum ratings**

Symbol	Parameter	Value	Unit
$V_{DS}$	Drain-source voltage	30	V
$V_{GS}$	Gate-source voltage	$\pm 22$	V
$I_D^{(1)}$	Drain current (continuous) at $T_C = 25\text{ }^\circ\text{C}$	78.5	A
$I_D^{(1)}$	Drain current (continuous) at $T_C = 100\text{ }^\circ\text{C}$	55.5	A
$I_D$	Drain current (continuous) at $T_{pcb} = 25\text{ }^\circ\text{C}$	20	A
$I_D$	Drain current (continuous) at $T_{pcb}=100\text{ }^\circ\text{C}$	14.2	A
$I_{DM}^{(2),(3)}$	Drain current (pulsed)	80	A
$P_{TOT}$	Total dissipation at $T_C = 25\text{ }^\circ\text{C}$	72	W
$P_{TOT}$	Total dissipation at $T_{pcb} = 25\text{ }^\circ\text{C}$	4.7	W
$T_J$ $T_{stg}$	Operating junction temperature Storage temperature	-55 to 175	$^\circ\text{C}$

1. Specified by design. Not subject to production test.
2. Pulse width limited by safe operating area
3. When mounted on FR-4 board of 1inch<sup>2</sup>, 2oz Cu, t < 10 sec

**Table 3. Thermal resistance**

Symbol	Parameter	Value	Unit
$R_{thj-case}$	Thermal resistance junction-case	2.08	$^\circ\text{C/W}$
$R_{thj-pcb}^{(1)}$	Thermal resistance junction-pcb	32	$^\circ\text{C/W}$

1. When mounted on FR-4 board of 1inch<sup>2</sup>, 2oz Cu, t < 10 sec

**Table 4. Avalanche data**

Symbol	Parameter	Value	Unit
$I_{AV}$	Not-repetitive avalanche current, (pulse width limited by $T_J$ max)	18.5	A
$E_{AS}^{(1)}$	Single pulse avalanche energy (starting $T_J = 25\text{ }^\circ\text{C}$ , $I_D = I_{AV}$ , $V_{DD} = 24\text{ V}$ )	270	mJ

1. Per channel.

Electrical characteristics

STL66DN3LLH5

## 2 Electrical characteristics

(T<sub>CASE</sub>= 25 °C unless otherwise specified)

**Table 5. On/off states**

Symbol	Parameter	Test conditions	Min.	Typ.	Max.	Unit
V <sub>(BR)DSS</sub>	Drain-source breakdown voltage (V <sub>GS</sub> = 0)	I <sub>D</sub> = 250 μA	30			V
I <sub>DSS</sub>	Zero gate voltage drain current (V <sub>GS</sub> = 0)	V <sub>DS</sub> = 30 V, V <sub>DS</sub> = 30 V, T <sub>C</sub> =125 °C			1 100	μA nA
I <sub>GSS</sub>	Gate body leakage current (V <sub>DS</sub> = 0)	V <sub>GS</sub> = ± 22 V			±10	μA
V <sub>GS(th)</sub>	Gate threshold voltage	V <sub>DS</sub> = V <sub>GS</sub> , I <sub>D</sub> = 250 μA	1		3	V
R <sub>DS(on)</sub>	Static drain-source on resistance	V <sub>GS</sub> = 10 V, I <sub>D</sub> = 10 A V <sub>GS</sub> = 4.5 V, I <sub>D</sub> = 10 A		5.9 7.1	6.5 7.9	mΩ mΩ

**Table 6. Dynamic**

Symbol	Parameter	Test conditions	Min.	Typ.	Max.	Unit
C <sub>iss</sub>	Input capacitance	V <sub>DS</sub> =25 V, f=1 MHz, V <sub>GS</sub> =0	-	1500	-	pF
C <sub>oss</sub>	Output capacitance			230		pF
C <sub>rss</sub>	Reverse transfer capacitance			23		pF
Q <sub>g</sub>	Total gate charge	V <sub>DD</sub> =15 V, I <sub>D</sub> = 19 A	-	12	-	nC
Q <sub>gs</sub>	Gate-source charge	V <sub>GS</sub> =4.5 V	-	5	-	nC
Q <sub>gd</sub>	Gate-drain charge	(see Figure 14)		4.4		nC

**Table 7. Switching times**

Symbol	Parameter	Test conditions	Min.	Typ.	Max.	Unit
t <sub>d(on)</sub>	Turn-on delay time	V <sub>DD</sub> =15 V, I <sub>D</sub> = 9.5 A, R <sub>G</sub> =4.7 Ω, V <sub>GS</sub> =10 V (see Figure 13)	-	8.8	-	ns
t <sub>r</sub>	Rise time			18		ns
t <sub>d(off)</sub>	Turn-off delay time			26		ns
t <sub>f</sub>	Fall time			4		ns

**STL66DN3LLH5**

**Electrical characteristics**

**Table 8. Source drain diode**

Symbol	Parameter	Test conditions	Min.	Typ.	Max.	Unit
$I_{SD}$	Source-drain current		-		20	A
$I_{SDM}^{(1)}$	Source-drain current (pulsed)		-		80	A
$V_{SD}^{(2)}$	Forward on voltage	$I_{SD} = 19\text{ A}, V_{GS}=0$	-		1.1	V
$t_{rr}$	Reverse recovery time	$I_{SD} = 19\text{ A},$ $di/dt = 100\text{ A}/\mu\text{s},$ $V_{DD}=25\text{ V}, T_j=150\text{ }^\circ\text{C}$	-	24		ns
$Q_{rr}$	Reverse recovery charge		-	12		nC
$I_{RRM}$	Reverse recovery current		-	1.8		A

1. Pulse width limited by safe operating area.
2. Pulsed: pulse duration=300 $\mu\text{s}$ , duty cycle 1.5%

Electrical characteristics

STL66DN3LLH5

**2.1 Electrical characteristics (curves)**

**Figure 2. Safe operating area**

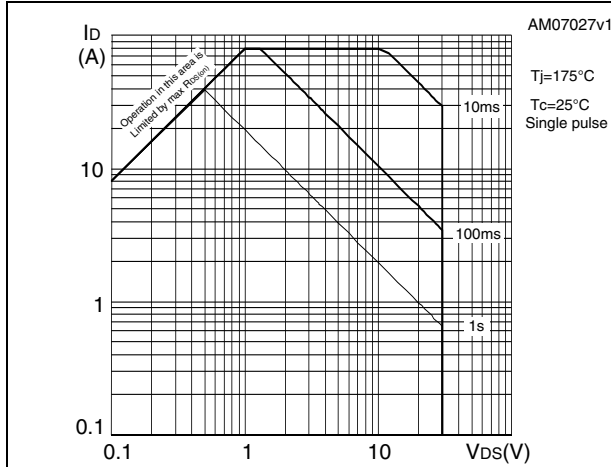

**Figure 3. Thermal impedance**

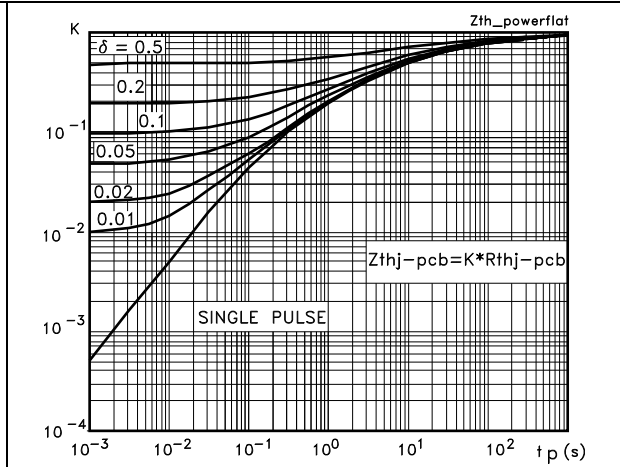

**Figure 4. Output characteristics**

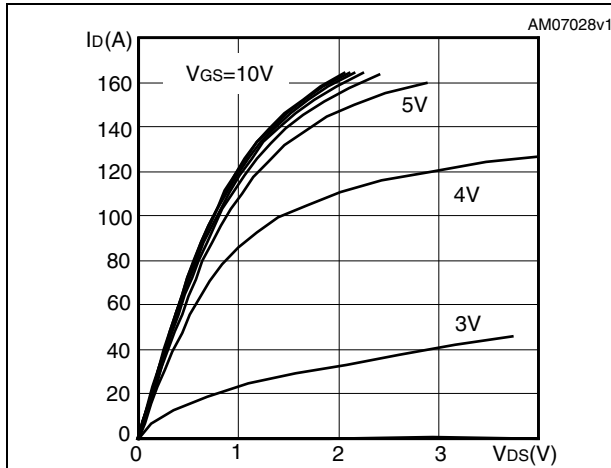

**Figure 5. Transfer characteristics**

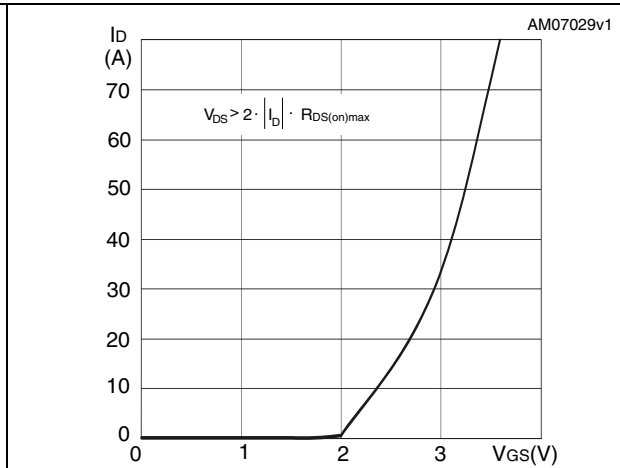

**Figure 6. Normalized  $BV_{DSS}$  vs temperature**

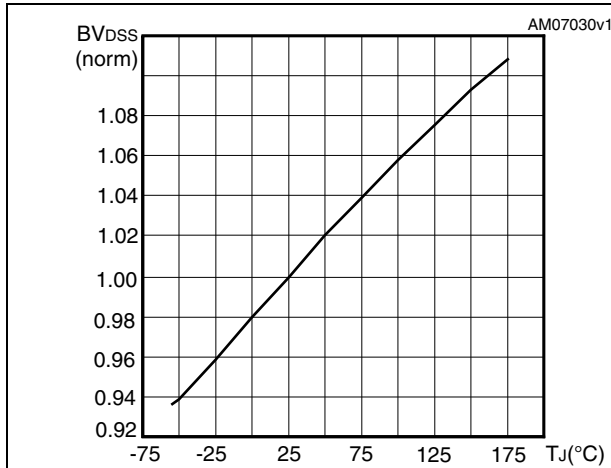

**Figure 7. Static drain-source on resistance**

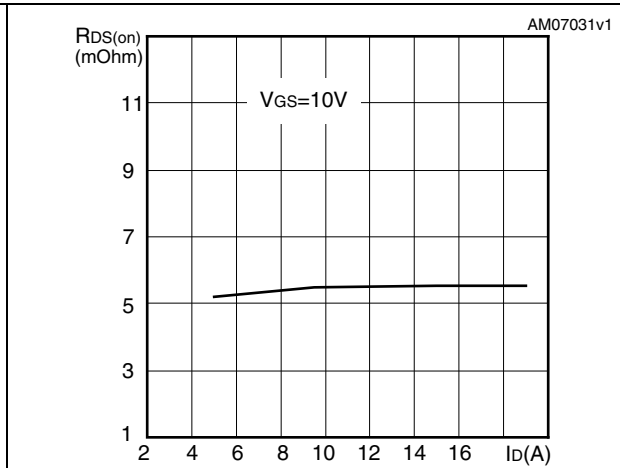

**STL66DN3LLH5**

**Electrical characteristics**

**Figure 8. Gate charge vs gate-source voltage** **Figure 9. Capacitance variations**

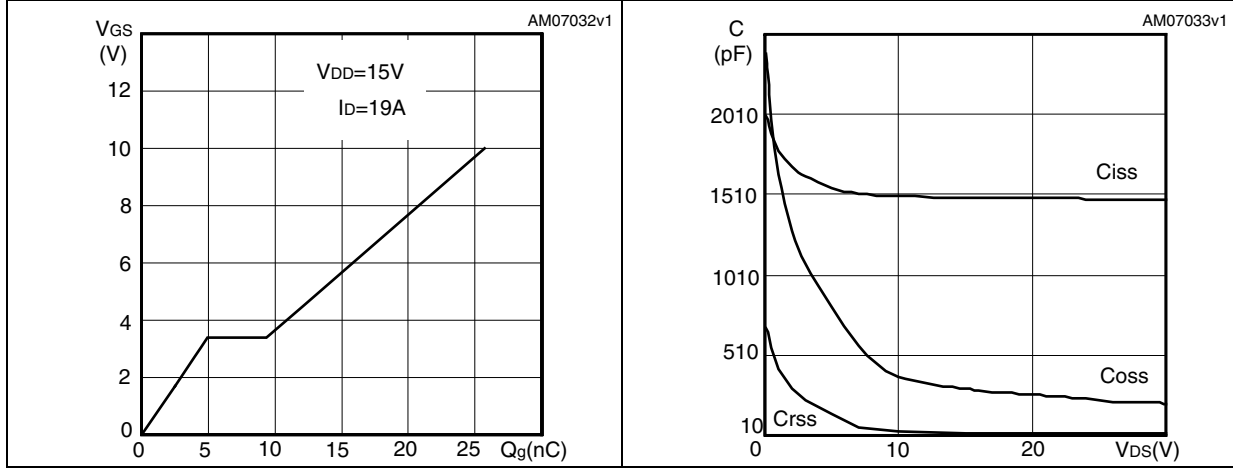

**Figure 10. Normalized gate threshold voltage vs temperature** **Figure 11. Normalized on resistance vs temperature**

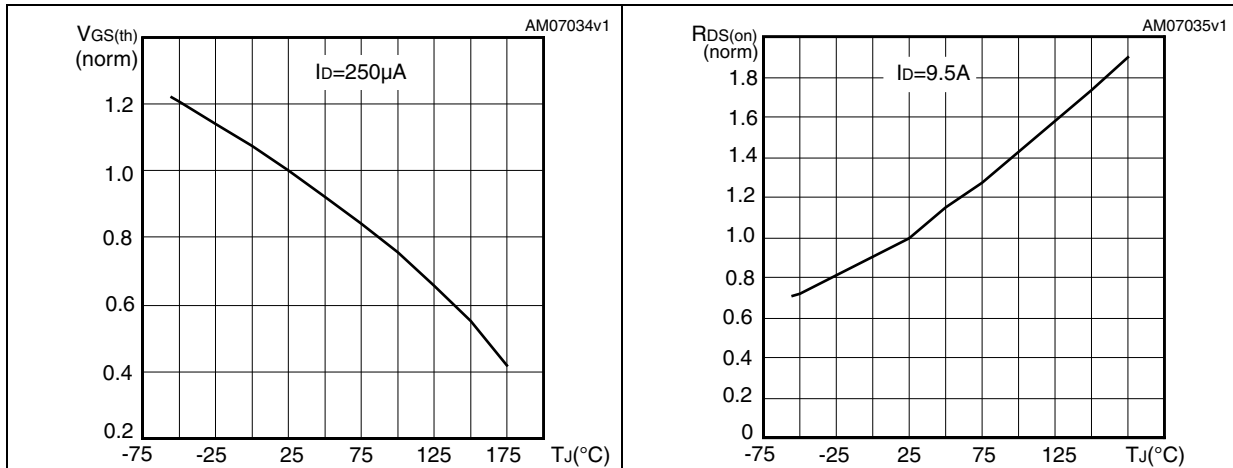

**Figure 12. Source-drain diode forward characteristics**

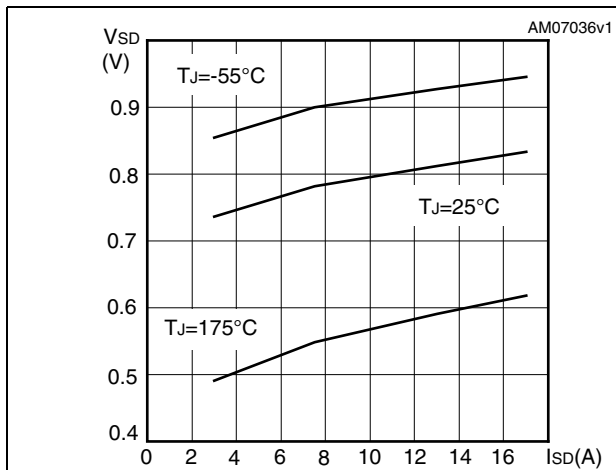



### 3 Test circuits

**Figure 13. Switching times test circuit for resistive load**

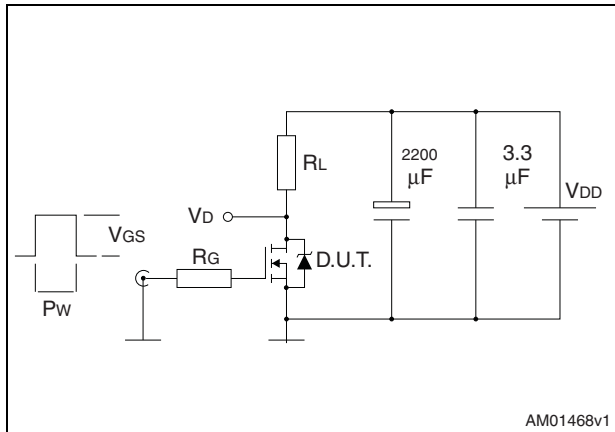

**Figure 14. Gate charge test circuit**

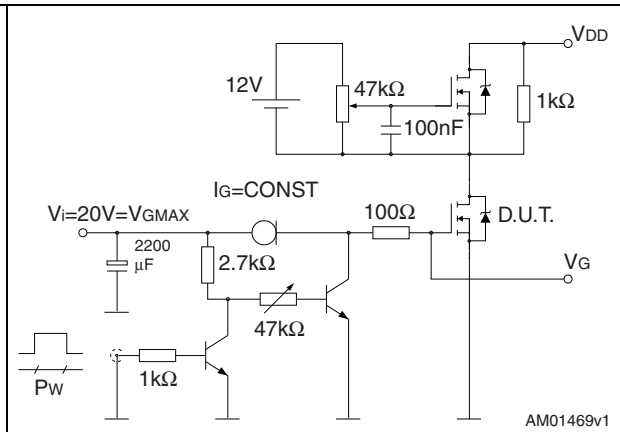

**Figure 15. Test circuit for inductive load switching and diode recovery times**

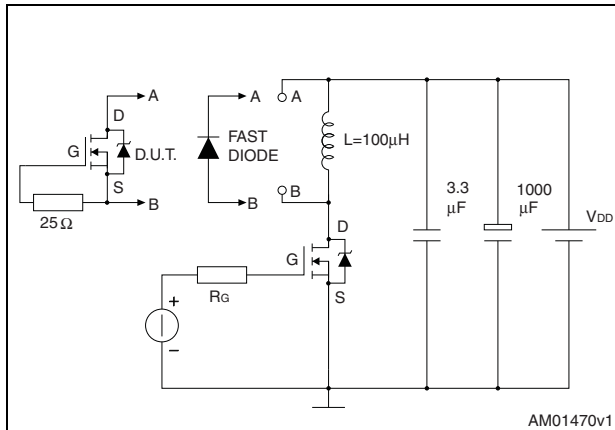

**Figure 16. Unclamped inductive load test circuit**

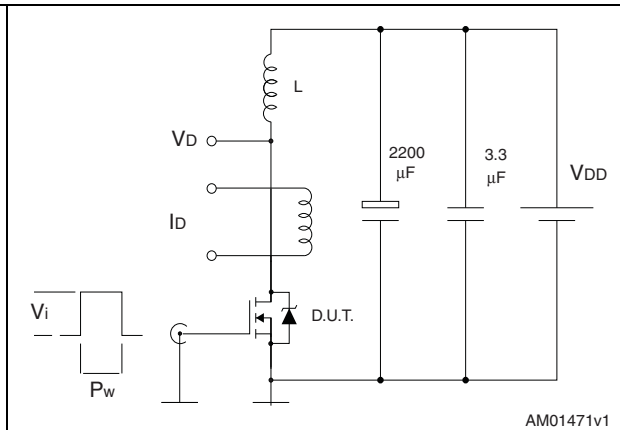

**Figure 17. Unclamped inductive waveform**

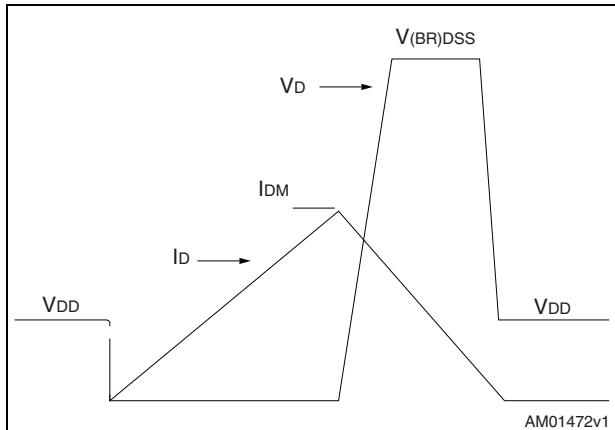

**Figure 18. Switching time waveform**

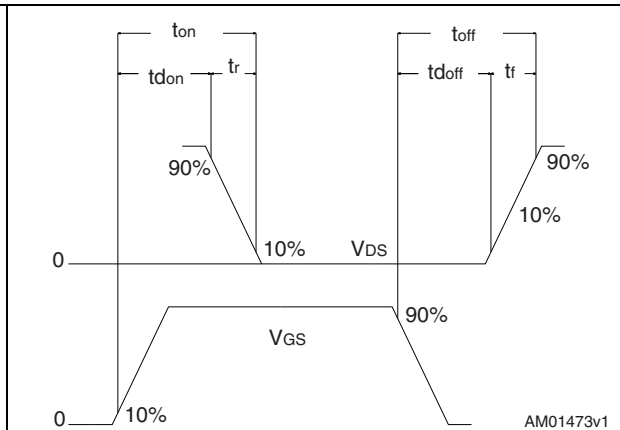

## 4 Package mechanical data

In order to meet environmental requirements, ST offers these devices in different grades of ECOPACK® packages, depending on their level of environmental compliance. ECOPACK® specifications, grade definitions and product status are available at: [www.st.com](http://www.st.com). ECOPACK is an ST trademark.

**Table 9. PowerFLAT™ 5x6 double island (clip) mechanical data**

Ref.	Dimensions (mm)		
	Min.	Typ.	Max.
A	0.80		1.00
A1	0.02		0.05
A2		0.25	
b	0.30		0.50
D		5.20	
E		6.15	
D2	1.68		1.88
E2	3.50		3.70
D3	1.68		1.88
E3	3.50		3.70
E4	0.55		0.75
e		1.27	
L	0.725		1.025
K	1.05		1.35

**Package mechanical data**

**STL66DN3LLH5**

**Figure 19. PowerFLAT™ 5x6 double island (clip) drawing**

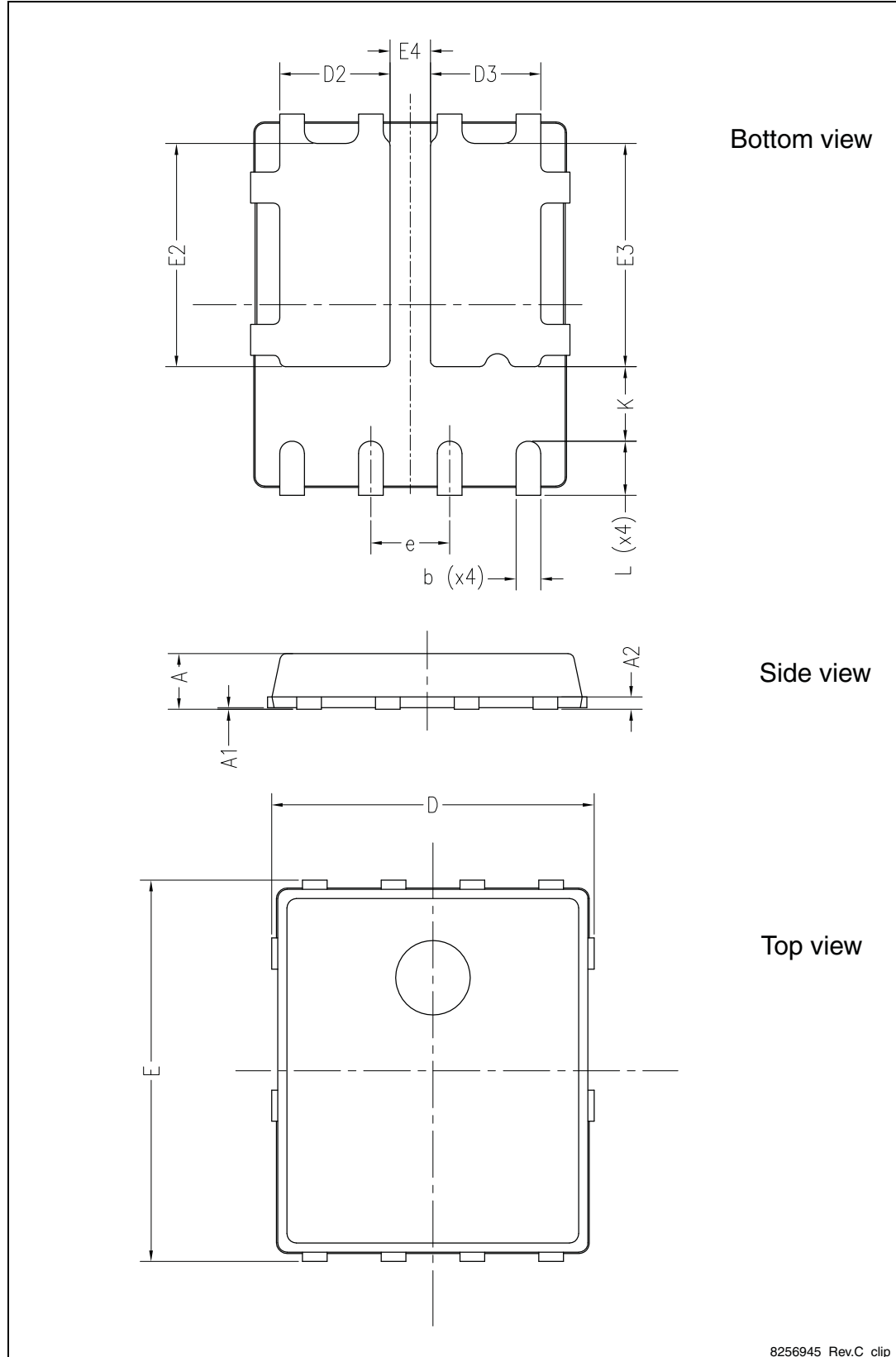

**STL66DN3LLH5**

**Package mechanical data**

**Figure 20. PowerFLAT™ 5x6 double island (clip) drawing recommended footprint (dimensions are in mm)**

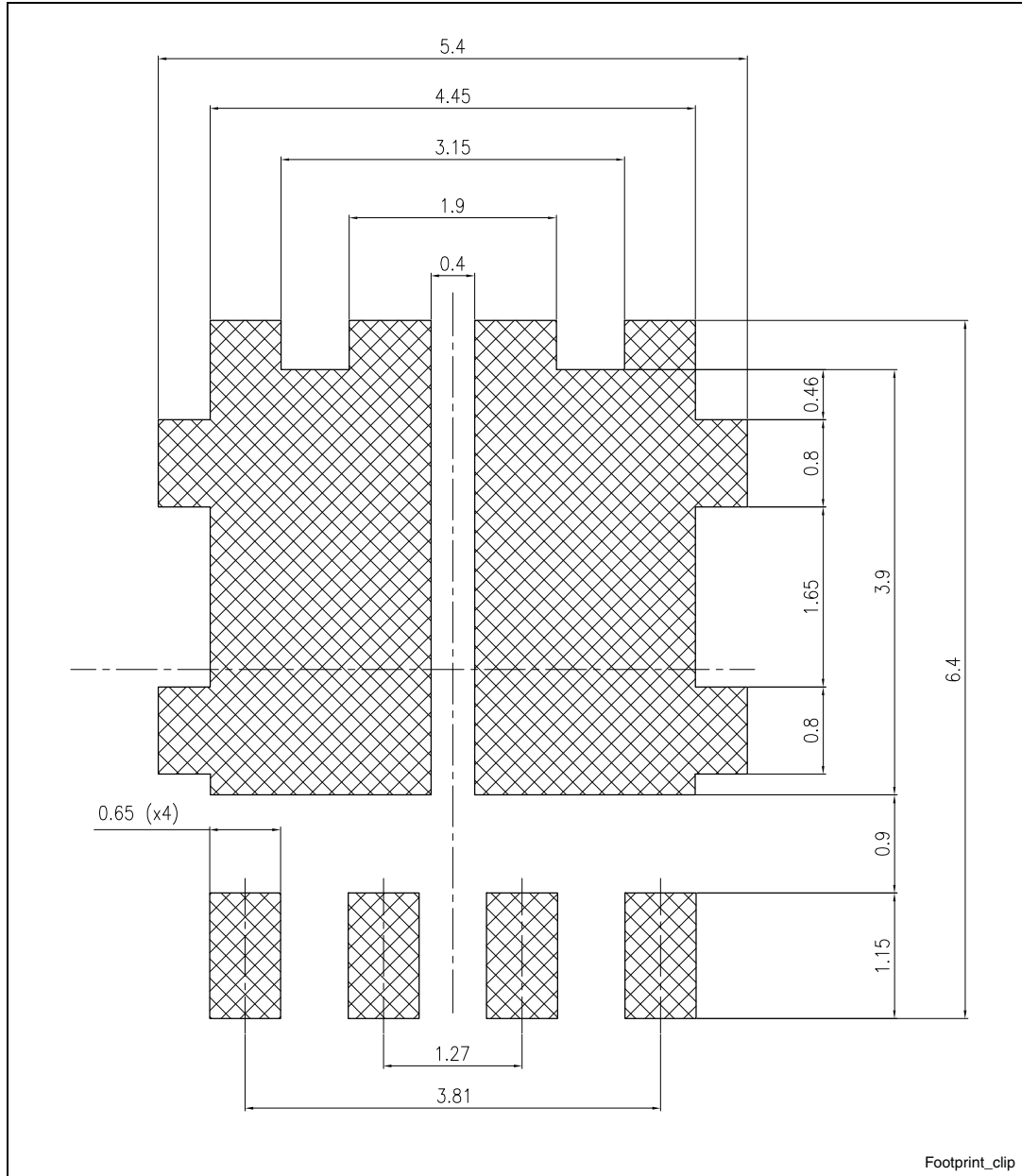

## 5 Packaging mechanical data

Figure 21. PowerFLAT™ 5x6 tape

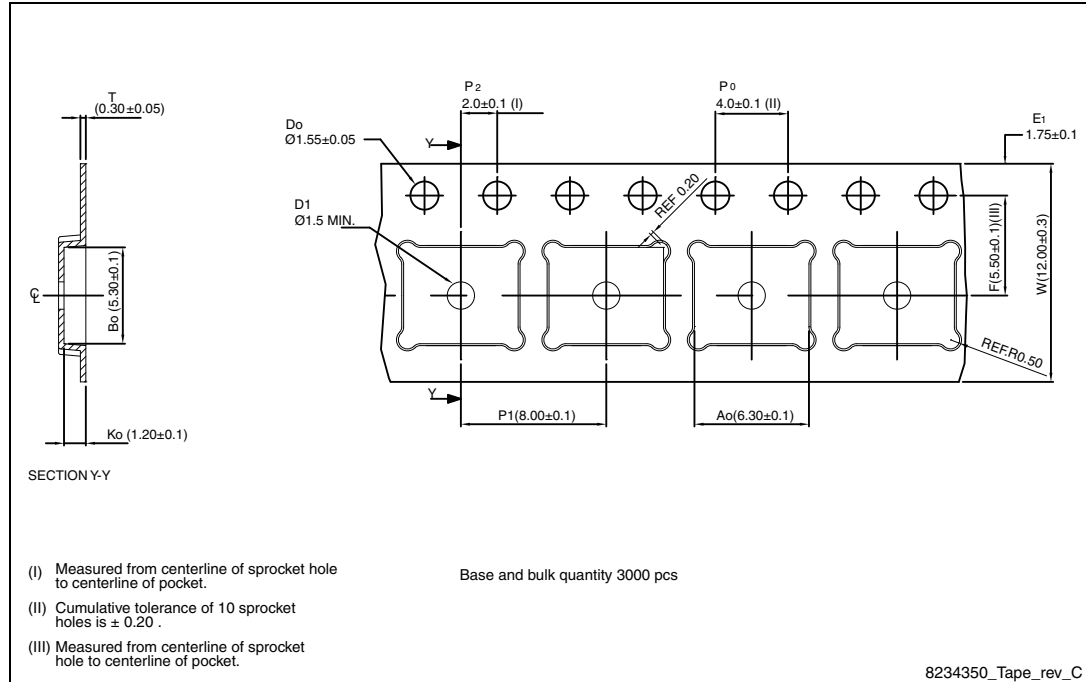
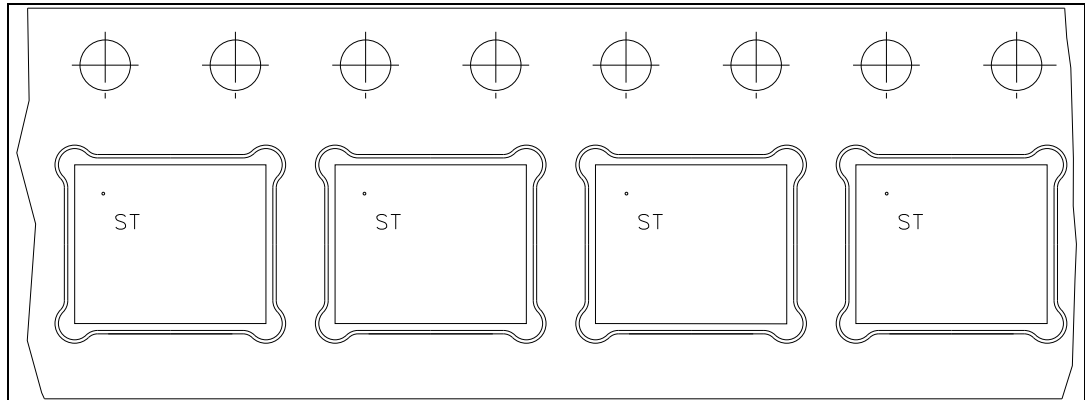

Figure 22. PowerFLAT™ 5x6 package orientation in carrier tape.



**STL66DN3LLH5**

**Packaging mechanical data**

**Figure 23. PowerFLAT™ 5x6 reel**

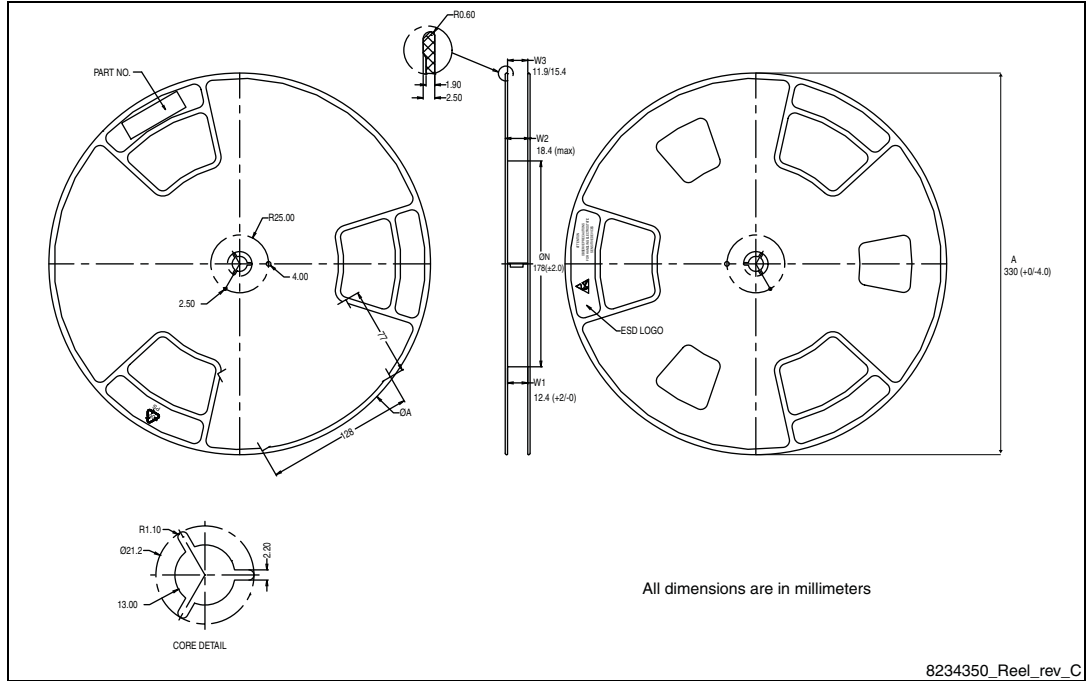

## 6 Revision history

Table 10. Document revision history

Date	Revision	Changes
12-Oct-2011	1	First release.
14-Mar-2012	2	Document status changed from preliminary data to production data. Inserted <a href="#">Section 5: Packaging mechanical data</a> . Minor text changes.

## STL66DN3LLH5

---

### **Please Read Carefully:**

Information in this document is provided solely in connection with ST products. STMicroelectronics NV and its subsidiaries ("ST") reserve the right to make changes, corrections, modifications or improvements, to this document, and the products and services described herein at any time, without notice.

All ST products are sold pursuant to ST's terms and conditions of sale.

Purchasers are solely responsible for the choice, selection and use of the ST products and services described herein, and ST assumes no liability whatsoever relating to the choice, selection or use of the ST products and services described herein.

No license, express or implied, by estoppel or otherwise, to any intellectual property rights is granted under this document. If any part of this document refers to any third party products or services it shall not be deemed a license grant by ST for the use of such third party products or services, or any intellectual property contained therein or considered as a warranty covering the use in any manner whatsoever of such third party products or services or any intellectual property contained therein.

**UNLESS OTHERWISE SET FORTH IN ST'S TERMS AND CONDITIONS OF SALE ST DISCLAIMS ANY EXPRESS OR IMPLIED WARRANTY WITH RESPECT TO THE USE AND/OR SALE OF ST PRODUCTS INCLUDING WITHOUT LIMITATION IMPLIED WARRANTIES OF MERCHANTABILITY, FITNESS FOR A PARTICULAR PURPOSE (AND THEIR EQUIVALENTS UNDER THE LAWS OF ANY JURISDICTION), OR INFRINGEMENT OF ANY PATENT, COPYRIGHT OR OTHER INTELLECTUAL PROPERTY RIGHT.**

**UNLESS EXPRESSLY APPROVED IN WRITING BY TWO AUTHORIZED ST REPRESENTATIVES, ST PRODUCTS ARE NOT RECOMMENDED, AUTHORIZED OR WARRANTED FOR USE IN MILITARY, AIR CRAFT, SPACE, LIFE SAVING, OR LIFE SUSTAINING APPLICATIONS, NOR IN PRODUCTS OR SYSTEMS WHERE FAILURE OR MALFUNCTION MAY RESULT IN PERSONAL INJURY, DEATH, OR SEVERE PROPERTY OR ENVIRONMENTAL DAMAGE. ST PRODUCTS WHICH ARE NOT SPECIFIED AS "AUTOMOTIVE GRADE" MAY ONLY BE USED IN AUTOMOTIVE APPLICATIONS AT USER'S OWN RISK.**

Resale of ST products with provisions different from the statements and/or technical features set forth in this document shall immediately void any warranty granted by ST for the ST product or service described herein and shall not create or extend in any manner whatsoever, any liability of ST.

ST and the ST logo are trademarks or registered trademarks of ST in various countries.

Information in this document supersedes and replaces all information previously supplied.

The ST logo is a registered trademark of STMicroelectronics. All other names are the property of their respective owners.

© 2012 STMicroelectronics - All rights reserved

STMicroelectronics group of companies

Australia - Belgium - Brazil - Canada - China - Czech Republic - Finland - France - Germany - Hong Kong - India - Israel - Italy - Japan - Malaysia - Malta - Morocco - Philippines - Singapore - Spain - Sweden - Switzerland - United Kingdom - United States of America

[www.st.com](http://www.st.com)