



Mini Family 110V Input

Actual size:
2.28 x 2.2 x 0.5in
57,9 x 55,9 x 12,7mm

DC-DC Converter Module

Features & Benefits

- DC input range: 66 – 154V (continuous)
- Isolated input
- Encapsulated circuitry for shock and vibration resistance
- Extended temperature range (–55 to +100°C)
- Input surge withstand: 250V for 100ms
- DC output: 3.3 – 48V
- Programmable output: 10 to 110%
- Regulation: ±0.2% no load to full load
- Efficiency: Up to 90%
- Maximum operating temp: 100°C, full load
- Power density: up to 80W per cubic inch
- Height above board: 0.43in. (10,9mm)
- Parallelable, with N+M fault tolerance
- Low noise ZCS/ZVS architecture
- RoHS Compliant (with F or G pin option)

Product Overview

These DC-DC converter modules use advanced power processing, control and packaging technologies to provide the performance, flexibility, reliability and cost effectiveness of a mature power component.

High frequency ZCS/ZVS switching provides high power density with low noise and high efficiency.

Applications

Railway/Transportation system applications including communications systems, information display, lighting, control systems, ticket machines, passenger entertainment, public address systems, door control, industrial power systems and power generation systems.

For details on proper operation please refer to the: [Design Guide & Applications Manual for Maxi, Mini, Micro Family.](#)

Absolute Maximum Ratings

Parameter	Rating	Unit	Notes
+In to –In voltage	–0.5 to +260	V _{DC}	
PC to –In voltage	–0.5 to +7.0	V _{DC}	
PR to –In voltage	–0.5 to +7.0	V _{DC}	
SC to –Out voltage	–0.5 to +1.5	V _{DC}	
–Sense to –Out voltage	1.0	V _{DC}	
Isolation voltage			
in to out	3000	V _{RMS}	Test voltage
in to base	1500	V _{RMS}	Test voltage
out to base	500	V _{RMS}	Test voltage
Operating Temperature	–55 to +100	°C	M-Grade
Storage Temperature	–65 to +125	°C	M-Grade
Pin soldering temperature	500 (260)	°F (°C)	<5 sec; wave solder
	750 (390)	°F (°C)	<7 sec; hand solder
Mounting torque	5 (0.57)	in-lbs (N-m)	6 each

Part Numbering

e.g. V110B24C200BL

V110B

Product Type
V = Standard
S = Enhanced efficiency (avail. ≤12 Vout only)

Output Voltage
3V3 = 3.3V
5 = 5V
8 = 8V
12 = 12V
15 = 15V
24 = 24V
28 = 28V
36 = 36V
48 = 48V

Product Grade Temperatures (°C)
 Grade Operating Storage
E = –10 to +100 –20 to +125
C = –20 to +100 –40 to +125
T = –40 to +100 –40 to +125
H = –40 to +100 –55 to +125
M = –55 to +100 –65 to +125

Output Power
 Vout Pout
 3.3V 75W, 100W
 5V 100W, 150W
 8V 150W
 12V 150W, 200W
 15V 150W, 200W
 24V 150W, 200W
 28V 150W, 200W
 36V 150W, 200W
 48V 150W, 200W

Pin Style
Blank: Short
L: Long
S: Short ModuMate
N: Long ModuMate
F: Short RoHS
G: Long RoHS
K: Extra Long RoHS
Finish
 Tin/Lead
 Gold
 Tin/Lead
 Gold
 Gold
 Gold
 Gold

Baseplate
Blank: Slotted
2: Threaded
3: Through-hole

Module Family Electrical Characteristics

Electrical characteristics apply over the full operating range of input voltage, output load (resistive) and baseplate temperature, unless otherwise specified. All temperatures refer to the operating temperature at the center of the baseplate.

MODULE INPUT SPECIFICATIONS

Parameter	Min	Typ	Max	Unit	Notes
Operating input voltage	66	110	154	V _{DC}	Per EN50155 and GBT-25119
Input surge withstand			250	V _{DC}	<100ms
Undervoltage turn-on		64	65.4	V _{DC}	
Undervoltage turn-off	54	56		V _{DC}	
Overvoltage turn-off/on	155.5	161.7	169.4	V _{DC}	
Disabled input current			1.3	mA	PC pin low

MODULE OUTPUT SPECIFICATIONS

Parameter	Min	Typ	Max	Unit	Notes
Output voltage setpoint			±1	% V _{out} nom.	Nominal input; full load; 25°C
Line regulation		±0.02	±0.20	%	Low line to high line; full load
Temperature regulation		±0.002	±0.005	% / °C	Over operating temperature range
Power sharing accuracy		±2	±5	%	10 to 100% of full load
Programming range	10		110	%	Of nominal output voltage. For trimming below 90% of nominal, a minimum load of 10% of maximum rated power may be required.
+Out to -Out, +Sense to -Out — Absolute Maximum Ratings					
3.3V			-0.5 to 4.7	V _{DC}	Externally applied
5V			-0.5 to 7.0	V _{DC}	Externally applied
8V			-0.5 to 10.9	V _{DC}	Externally applied
12V			-0.5 to 16.1	V _{DC}	Externally applied
15V			-0.5 to 20.0	V _{DC}	Externally applied
24V			-0.5 to 31.7	V _{DC}	Externally applied
28V			-0.5 to 36.9	V _{DC}	Externally applied
36V			-0.5 to 47.4	V _{DC}	Externally applied
48V			-0.5 to 62.9	V _{DC}	Externally applied

Note: For important information relative to applications where the converter modules are subject to continuous dynamic loading, contact Vicor applications engineering at 800-927-9474.

THERMAL RESISTANCE AND CAPACITY

Parameter	Min	Typ	Max	Unit
Baseplate to sink; flat, greased surface		0.16		°C/Watt
Baseplate to sink; thermal pad (P/N 20264)		0.14		°C/Watt
Baseplate to ambient		8.0		°C/Watt
Baseplate to ambient; 1000 LFM		1.9		°C/Watt
Thermal capacity		83		Watt-sec/°C

Module Family Electrical Characteristics (Cont.)

MODULE CONTROL SPECIFICATIONS

Parameter	Min	Typ	Max	Unit	Notes
Primary Side (PC = Primary Control; PR = Parallel)					
PC bias voltage	5.50	5.75	6.00	V _{DC}	PC current = 1.0mA PC voltage = 5.5V During normal operation
current limit	1.5	2.1	3.0	mA	
PC module disable	2.3	2.6	2.9	V _{DC}	Switch must be able to sink ≥4mA. See Fig. 2
PC module enable delay		4	7	ms	
PC module alarm			0.5	V _{avg}	UV, OV, OT, module fault. See Figs. 3 and 5
PC resistance	0.9	1.0	1.1	MΩ	See Fig. 3, converter off or fault mode
PR emitter amplitude	5.7	5.9	6.1	Volts	PR load >30Ω, <30pF
PR emitter current	150			mA	
PR receiver impedance	375	500	625	Ω	25°C
PR receiver threshold	2.4	2.5	2.6	Volts	Minimum pulse width: 20ns
PR drive capability			12	modules	Without PR buffer amplifier
Secondary Side (SC = Secondary Control)					
SC bandgap voltage	1.21	1.23	1.25	V _{DC}	Referenced to –Sense
SC resistance	990	1000	1010	Ω	
SC capacitance		0.033		μF	
SC module alarm		0		V _{DC}	With open trim; referenced to –Sense. See Fig. 7

MODULE GENERAL SPECIFICATIONS

Parameter	Min	Typ	Max	Unit	Notes
Remote sense (total drop)			0.5	V _{DC}	0.25V per leg (sense leads must be connected to respective, output terminals)
Isolation test voltage (in to out)*	3000			V _{RMS}	Complies with reinforced insulation requirements
Isolation test voltage (in to base)*	1500			V _{RMS}	Complies with basic insulation requirements
Isolation test voltage (out to base)*	500			V _{RMS}	Complies with operational insulation requirements
Isolation resistance		10		MΩ	in to out, in to baseplate, out to baseplate
Weight (E, C, T grade)	3.1 (89.3)	3.5 (100.3)	3.9 (111.3)	ounces (grams)	
Weight (H, M grade)	3.5 (99.6)	3.9 (110.6)	4.3 (121.6)	ounces (grams)	
Temperature limiting	100	115		°C	See Figs. 3 and 5. Do not operate converter >100C.
Agency approvals		cURus, cTÜVus, CE			UL60950-1, EN60950-1, CSA60950-1, IEC60950-1. With appropriate fuse in series with the +Input

* Isolation test voltage, 1 minute or less.

Note: Specifications are subject to change without notice.

MODULE SPECIFIC OPERATING SPECIFICATIONS

3.3V_{OUT}, 100W (e.g. S110B3V3C100BL, V110B3V3C100BL)

Parameter	Min	Typ	Max	Unit	Notes
Efficiency					
S110B3V3C100BL (enhanced efficiency)	83.1	86.5		%	Nominal input; full load; 25°C
V110B3V3C100BL (standard efficiency)	81.5	82.6			
Ripple and noise		80	100	mV	p-p; Nominal input; full load; 20MHz bandwidth
Output OVP setpoint	4.14	4.3	4.46	Volts	25°C; recycle input voltage or PC to restart (>100ms off)
Dissipation, standby		2.6	3.4	Watts	No load
Load regulation		±0.02	±0.2	%	No load to full load; nominal input
Load current	0		30.3	Amps	
Current limit	30.9	34.8	41	Amps	Output voltage 95% of nominal
Short circuit current	21.2	34.8	41	Amps	Output voltage <250mV

3.3V_{OUT}, 75W (e.g. S110B3V3C75BL, V110B3V3C75BL)

Parameter	Min	Typ	Max	Unit	Notes
Efficiency					
S110B3V3C75BL (enhanced efficiency)	82.2	86.0		%	Nominal input; full load; 25°C
V110B3V3C75BL (standard efficiency)	81.0	81.9			
Ripple and noise		80	100	mV	p-p; Nominal input; full load; 20MHz bandwidth
Output OVP setpoint	4.14	4.3	4.46	Volts	25°C; recycle input voltage or PC to restart (>100ms off)
Dissipation, standby		2.6	3.6	Watts	No load
Load regulation		±0.02	±0.2	%	No load to full load; nominal input
Load current	0		22.73	Amps	
Current limit	23.1	26.1	30.7	Amps	Output voltage 95% of nominal
Short circuit current	15.8	26.1	30.7	Amps	Output voltage <250mV

5V_{OUT}, 150W (e.g. S110B5C150BL, V110B5C150BL)

Parameter	Min	Typ	Max	Unit	Notes
Efficiency					
S110B5C150BL (enhanced efficiency)	85.4	88.5		%	Nominal input; full load; 25°C
V110B5C150BL (standard efficiency)	83.9	84.8			
Ripple and noise		85	107	mV	p-p; Nominal input; full load; 20MHz bandwidth
Output OVP setpoint	6.03	6.25	6.47	Volts	25°C; recycle input voltage or PC to restart (>100ms off)
Dissipation, standby		5.3	7.5	Watts	No load
Load regulation		±0.02	±0.2	%	No load to full load; nominal input
Load current	0		30	Amps	
Current limit	30.6	34.5	40.5	Amps	Output voltage 95% of nominal
Short circuit current	21	34.5	40.5	Amps	Output voltage <250mV

5V_{OUT}, 100W (e.g. S110B5C100BL, V110B5C100BL)

Parameter	Min	Typ	Max	Unit	Notes
Efficiency					
S110B5C100BL (enhanced efficiency)	83.0	86.0		%	Nominal input; full load; 25°C
V110B5C100BL (standard efficiency)	80.5	81.9			
Ripple and noise		240	300	mV	p-p; Nominal input; full load; 20MHz bandwidth
Output OVP setpoint	6.03	6.25	6.47	Volts	25°C; recycle input voltage or PC to restart (>100ms off)
Dissipation, standby		3.4	4.4	Watts	No load
Load regulation		±0.02	±0.2	%	No load to full load; nominal input
Load current	0		20	Amps	
Current limit	20.4	23	27	Amps	Output voltage 95% of nominal
Short circuit current	14	23	27	Amps	Output voltage <250mV

MODULE SPECIFIC OPERATING SPECIFICATIONS (CONT.)

8V_{OUT}, 150W (e.g. S110B8C150BL, V110B8C150BL)

Parameter	Min	Typ	Max	Unit	Notes
Efficiency					
S110B8C150BL (enhanced efficiency)	87.3	89.0		%	Nominal input; full load; 25°C
V110B8C150BL (standard efficiency)	85.5	86.8			
Ripple and noise		200	250	mV	p-p; Nominal input; full load; 20MHz bandwidth
Output OVP setpoint	9.36	9.7	10.1	Volts	25°C; recycle input voltage or PC to restart (>100ms off)
Dissipation, standby		5.2	6.4	Watts	No load
Load regulation		±0.02	±0.2	%	No load to full load; nominal input
Load current	0		18.75	Amps	
Current limit	19.1	21.6	25.4	Amps	Output voltage 95% of nominal
Short circuit current	13.1	21.6	25.4	Amps	Output voltage <250mV

12V_{OUT}, 200W (e.g. S110B12C200BL, V110B12C200BL)

Parameter	Min	Typ	Max	Unit	Notes
Efficiency					
S110B12C200BL (enhanced efficiency)	87.9	89.0		%	Nominal input; full load; 25°C
V110B12C200BL (standard efficiency)	86.0	87.2			
Ripple and noise		185	232	mV	p-p; Nominal input; full load; 20MHz bandwidth
Output OVP setpoint	13.7	14.3	14.9	Volts	25°C; recycle input voltage or PC to restart (>100ms off)
Dissipation, standby		7	8.2	Watts	No load
Load regulation		±0.02	±0.2	%	No load to full load; nominal input
Load current	0		16.67	Amps	
Current limit	17	19.2	22.6	Amps	Output voltage 95% of nominal
Short circuit current	11.6	19.2	22.6	Amps	Output voltage <250mV

12V_{OUT}, 150W (e.g. S110B12C150BL, V110B12C150BL)

Parameter	Min	Typ	Max	Unit	Notes
Efficiency					
S110B12C150BL (enhanced efficiency)	88.9	90.0		%	Nominal input; full load; 25°C
V110B12C150BL (standard efficiency)	87.0	88.0			
Ripple and noise		160	200	mV	p-p; Nominal input; full load; 20MHz bandwidth
Output OVP setpoint	13.7	14.3	14.9	Volts	25°C; recycle input voltage or PC to restart (>100ms off)
Dissipation, standby		4.7	5.8	Watts	No load
Load regulation		±0.02	±0.2	%	No load to full load; nominal input
Load current	0		12.5	Amps	
Current limit	12.7	14.4	16.9	Amps	Output voltage 95% of nominal
Short circuit current	8.75	14.4	16.9	Amps	Output voltage <250mV

15V_{OUT}, 200W (e.g. V110B15C200BL)

Parameter	Min	Typ	Max	Unit	Notes
Efficiency	87.0	88.1		%	Nominal input; full load; 25°C
Ripple and noise		240	300	mV	p-p; Nominal input; full load; 20MHz bandwidth
Output OVP setpoint	17.1	17.8	18.5	Volts	25°C; recycle input voltage or PC to restart (>100ms off)
Dissipation, standby		7.3	8.2	Watts	No load
Load regulation		±0.02	±0.2	%	No load to full load; nominal input
Load current	0		13.33	Amps	
Current limit	13.5	15.3	18	Amps	Output voltage 95% of nominal
Short circuit current	6.5	15.3	18	Amps	Output voltage <250mV

MODULE SPECIFIC OPERATING SPECIFICATIONS (CONT.)

15V_{OUT}, 150W (e.g. V110B15C150BL)

Parameter	Min	Typ	Max	Unit	Notes
Efficiency	88.0	89.1		%	Nominal input; full load; 25°C
Ripple and noise		208	260	mV	p-p; Nominal input; full load; 20MHz bandwidth
Output OVP setpoint	17.1	17.8	18.5	Volts	25°C; recycle input voltage or PC to restart (>100ms off)
Dissipation, standby		4.9	5.7	Watts	No load
Load regulation		±0.02	±0.2	%	No load to full load; nominal input
Load current	0		10	Amps	
Current limit	10.2	11.5	13.5	Amps	Output voltage 95% of nominal
Short circuit current	7	11.5	13.5	Amps	Output voltage <250mV

24V_{OUT}, 200W (e.g. V110B24C200BL)

Parameter	Min	Typ	Max	Unit	Notes
Efficiency	86.4	87.3		%	Nominal input; full load; 25°C
Ripple and noise		200	250	mV	p-p; Nominal input; full load; 20MHz bandwidth
Output OVP setpoint	27.1	28.1	29.1	Volts	25°C; recycle input voltage or PC to restart (>100ms off)
Dissipation, standby		8.3	9.7	Watts	No load
Load regulation		±0.02	±0.2	%	No load to full load; nominal input
Load current	0		8.33	Amps	
Current limit	8.49	9.58	11.3	Amps	Output voltage 95% of nominal
Short circuit current	5.83	9.58	11.3	Amps	Output voltage <250mV

24V_{OUT}, 150W (e.g. V110B24C150BL)

Parameter	Min	Typ	Max	Unit	Notes
Efficiency	88	89.2		%	Nominal input; full load; 25°C
Ripple and noise		124	155	mV	p-p; Nominal input; full load; 20MHz bandwidth
Output OVP setpoint	27.1	28.1	29.1	Volts	25°C; recycle input voltage or PC to restart (>100ms off)
Dissipation, standby		3.5	4.1	Watts	No load
Load regulation		±0.02	±0.2	%	No load to full load; nominal input
Load current	0		6.25	Amps	
Current limit	6.37	7.19	8.44	Amps	Output voltage 95% of nominal
Short circuit current	4.37	7.19	8.44	Amps	Output voltage <250mV

28V_{OUT}, 200W (e.g. V110B28C200BL)

Parameter	Min	Typ	Max	Unit	Notes
Efficiency	86.5	87.5		%	Nominal input; full load; 25°C
Ripple and noise		240	300	mV	p-p; Nominal input; full load; 20MHz bandwidth
Output OVP setpoint	31.5	32.7	33.9	Volts	25°C; recycle input voltage or PC to restart (>100ms off)
Dissipation, standby		8.6	9.4	Watts	No load
Load regulation		±0.02	±0.2	%	No load to full load; nominal input
Load current	0		7.14	Amps	
Current limit	7.28	8.21	9.64	Amps	Output voltage 95% of nominal
Short circuit current	4.99	8.21	9.64	Amps	Output voltage <250mV

MODULE SPECIFIC OPERATING SPECIFICATIONS (CONT.)

28V_{OUT}, 150W (e.g. V110B28C150BL)

Parameter	Min	Typ	Max	Unit	Notes
Efficiency	87.9	89.2		%	Nominal input; full load; 25°C
Ripple and noise		180	225	mV	p-p; Nominal input; full load; 20MHz bandwidth
Output OVP setpoint	31.5	32.7	33.9	Volts	25°C; recycle input voltage or PC to restart (>100ms off)
Dissipation, standby		4.5	5.5	Watts	No load
Load regulation		±0.02	±0.2	%	No load to full load; nominal input
Load current	0		5.36	Amps	
Current limit	5.46	6.16	7.24	Amps	Output voltage 95% of nominal
Short circuit current	3.75	6.16	7.24	Amps	Output voltage <250mV

36V_{OUT}, 200W (e.g. V110B36C200BL)

Parameter	Min	Typ	Max	Unit	Notes
Efficiency	88.0	88.7		%	Nominal input; full load; 25°C
Ripple and noise		200	250	mV	p-p; Nominal input; full load; 20MHz bandwidth
Output OVP setpoint	40.4	41.9	43.4	Volts	25°C; recycle input voltage or PC to restart (>100ms off)
Dissipation, standby		6.8	7.8	Watts	No load
Load regulation		±0.02	±0.2	%	No load to full load; nominal input
Load current	0		5.56	Amps	
Current limit	5.67	6.39	7.51	Amps	Output voltage 95% of nominal
Short circuit current	3.89	6.39	7.51	Amps	Output voltage <250mV

36V_{OUT}, 150W (e.g. V110B36C150BL)

Parameter	Min	Typ	Max	Unit	Notes
Efficiency	85.5	87.0		%	Nominal input; full load; 25°C
Ripple and noise		160	200	mV	p-p; Nominal input; full load; 20MHz bandwidth
Output OVP setpoint	40.4	41.9	43.4	Volts	25°C; recycle input voltage or PC to restart (>100ms off)
Dissipation, standby		7	9.7	Watts	No load
Load regulation		±0.02	±0.2	%	No load to full load; nominal input
Load current	0		4.17	Amps	
Current limit	4.25	4.8	5.63	Amps	Output voltage 95% of nominal
Short circuit current	2.91	4.8	5.63	Amps	Output voltage <250mV

48V_{OUT}, 200W (e.g. V110B48C200BL)

Parameter	Min	Typ	Max	Unit	Notes
Efficiency	86.8	87.7		%	Nominal input; full load; 25°C
Ripple and noise		80	100	mV	p-p; Nominal input; full load; 20MHz bandwidth
Output OVP setpoint	53.7	55.7	57.7	Volts	25°C; recycle input voltage or PC to restart (>100ms off)
Dissipation, standby		7.7	12.4	Watts	No load
Load regulation		±0.02	±0.2	%	No load to full load; nominal input
Load current	0		4.17	Amps	
Current limit	4.25	4.8	5.63	Amps	Output voltage 95% of nominal
Short circuit current	2.91	4.8	5.63	Amps	Output voltage <250mV

MODULE SPECIFIC OPERATING SPECIFICATIONS (CONT.)

48V_{OUT}, 150W (e.g. V110B48C150BL)

Parameter	Min	Typ	Max	Unit	Notes
Efficiency	85.9	86.9		%	Nominal input; full load; 25°C
Ripple and noise		120	336	mVpp	p-p; Nominal input; full load; 20MHz bandwidth
Output OVP setpoint	53.7	55.7	57.7	Volts	25°C; recycle input voltage or PC to restart (>100ms off)
Dissipation, standby		6.1	6.9	Watts	No load
Load regulation		±0.02	±0.2	%	No load to full load; nominal input
Load current	0		3.13	Amps	
Current limit	3.19	3.6	4.23	Amps	Output voltage 95% of nominal
Short circuit current	2.19	3.6	4.53	Amps	Output voltage <250mV

Basic Module Operation

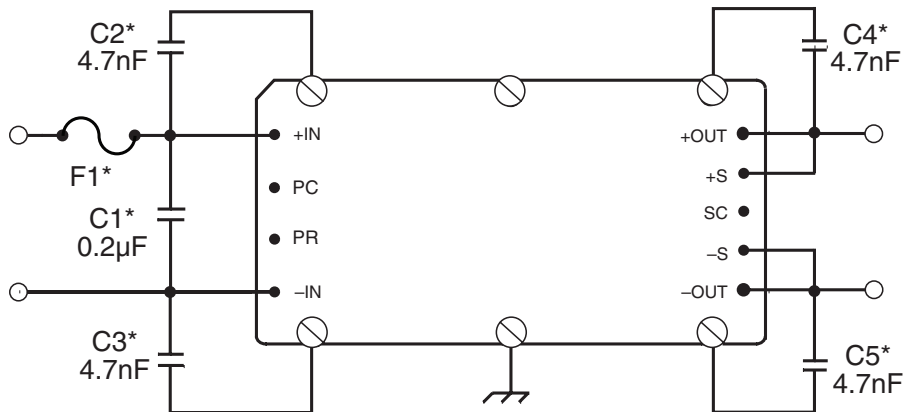

For C1 – C5, keep leads and connections short.

Figure 1 — Basic module operation requires fusing, grounding, bypassing capacitors.* See Maxi, Mini, Micro Design Guide.

Comprehensive Online Application Information



The Design Guide and Applications Manual includes:

- Application circuits
- Design requirements
- EMC considerations
- Current sharing in power arrays
- Thermal performance information
- Recommended soldering methods
- Accessory modules – filtering, rectification, front-ends
- Mounting options
- ...and more.

[CLICK HERE TO VIEW DESIGN GUIDE](#)

Also at vicorpower.com

- PowerBench online configurators
- Over 20 Application Notes
- Online calculators – thermal, trimming, hold-up
- PDF data sheets for ALL Vicor products

Primary Control - PC PIN

Module Enable/Disable

The module may be disabled by pulling PC to 0V (2.3V max) with respect to the -Input. This may be done with an open collector transistor, relay, or optocoupler. Converters may be disabled with a single transistor or relay either directly or via "OR'ing" diodes for 2 or more converters. See Figure 2.

Primary Auxiliary Supply

During normal operation only, the PC Pin can source 5.7V @ 1.5mA. In the example shown in Figure 4, PC powers a module enabled LED.

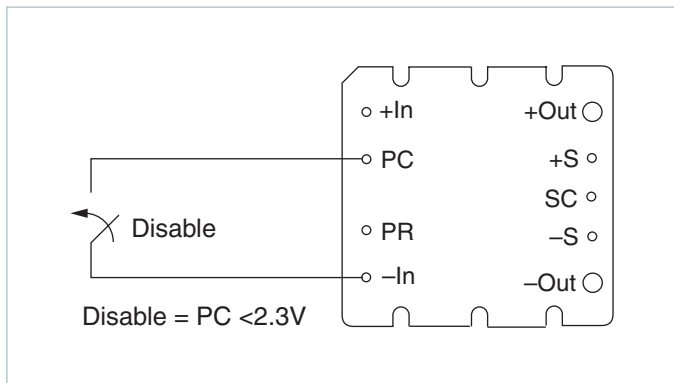

Figure 2 — Module enable/disable

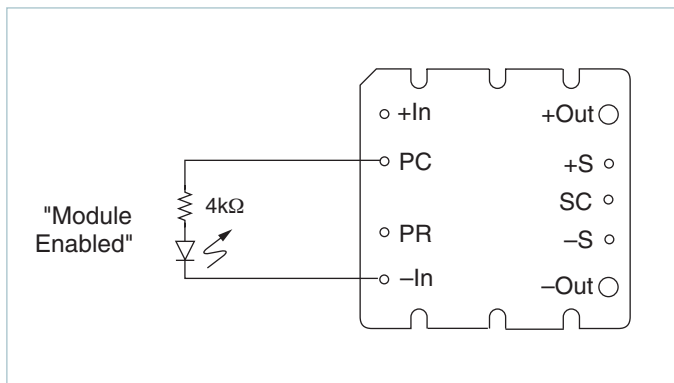

Figure 4 — LED on-state indicator

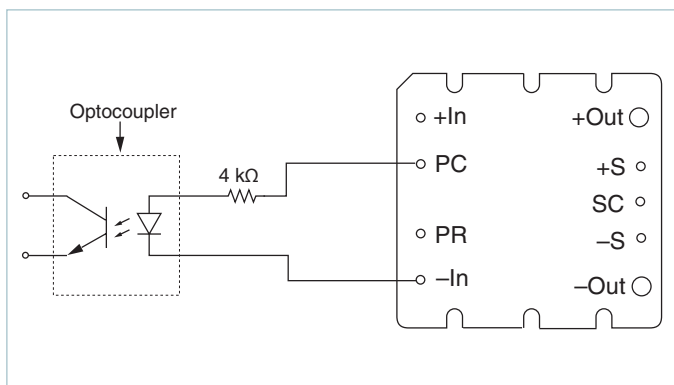

Figure 6 — Isolated on-state indicator

Module Alarm

The module contains "watchdog" circuitry which monitors input voltage, operating temperature and internal operating parameters. In the event that any of these parameters are outside of their allowable operating range, the module will shut down and PC will go low. PC will periodically go high and the module will check to see if the fault (as an example, Input Undervoltage) has cleared. If the fault has not been cleared, PC will go low again and the cycle will restart. The SC pin will go low in the event of a fault and return to its normal state after the fault has been cleared. See Figures 3 and 5.

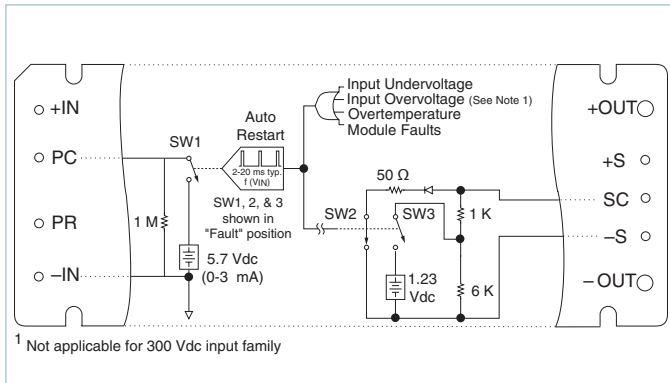

Figure 3 — PC/SC module alarm logic

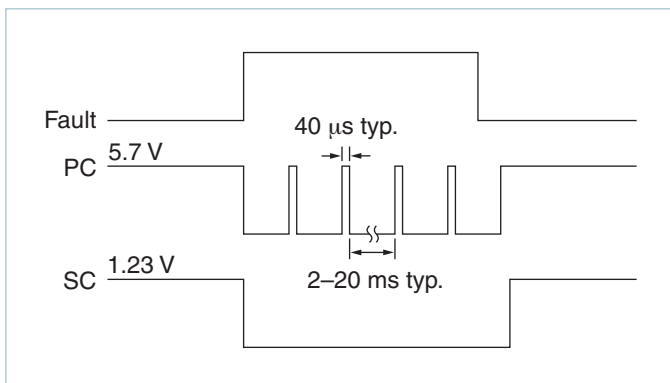

Figure 5 — PC/SC module alarm timing

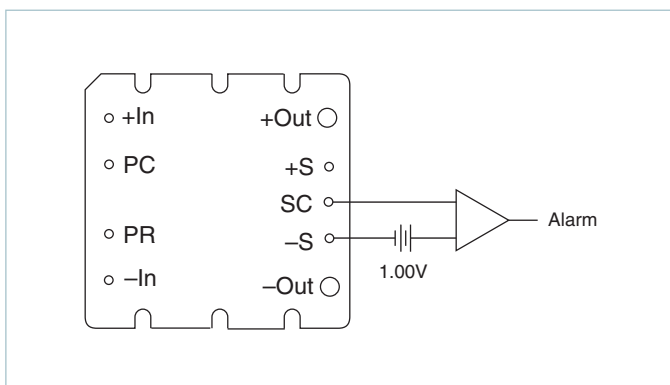

Figure 7 — Secondary side on-state indicator

Secondary Control - SC PIN

Output Voltage Programming

The output voltage of the converter can be adjusted or programmed via fixed resistors, potentiometers or voltage DACs. See Figure 8.

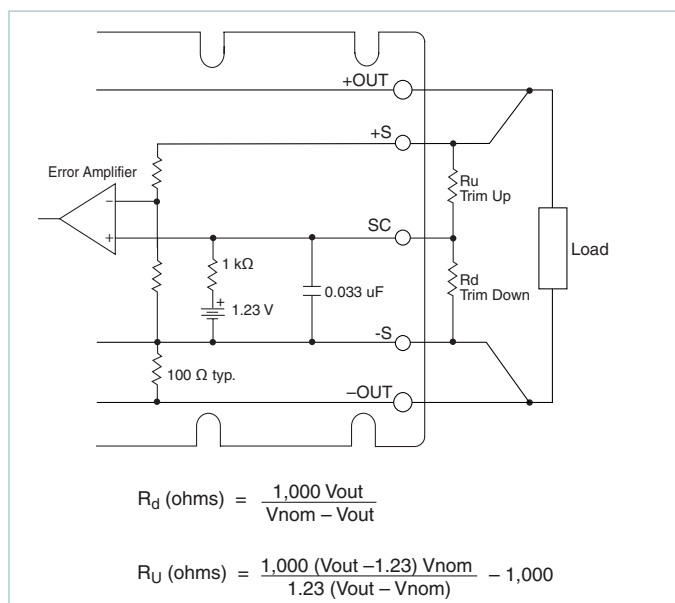

Figure 8 — Output voltage trim down and trim up circuit

Trim Down

1. This converter is not a constant power device – it has a constant current limit. Hence, available output power is reduced by the same percentage that output voltage is trimmed down. Do not exceed maximum rated output current.
2. The trim down resistor must be connected between the SC and -S pins. Do not bypass the SC pin directly with a capacitor.

Trim Up

1. The converter is rated for a maximum delivered power. To ensure that maximum rated power is not exceeded, reduce maximum output current by the same percentage increase in output voltage.
2. The trim up resistor must be connected between the SC and +S pins. Do not bypass the SC pin directly with a capacitor.
3. Do not trim the converter above maximum trim range (typically +10%) or the output over voltage protection circuitry may be activated..

Trim resistor values calculated automatically:

On-line calculators for trim resistor values are available on the vicor website at:

asp.vicorpower.com/calculators/calculators.asp?calc=1
Resistor values can be calculated for fixed trim up, fixed trim down and for variable trim up or down.

Parallel Bus - PR PIN

Parallel Operation

The PR pin supports paralleling for increased power with N+1 (N+M) redundancy. Modules of the same input voltage, output voltage, and power level will current share if all PR pins are suitably interfaced.

Compatible interface architectures include the following:

AC coupled single-wire interface. All PR pins are connected to a single communication bus through 0.001μF (500V) capacitors. This interface supports current sharing and is fault tolerant except for the communication bus. Up to three converters may be paralleled by this method. See Figure 9.

Transformer coupled interface. For paralleling four or more converters a transformer coupled interface is required. See Figure 10.

For details on parallel operation please refer to the

[Design Guide & Applications Manual for Maxi, Mini, Micro Family.](#)

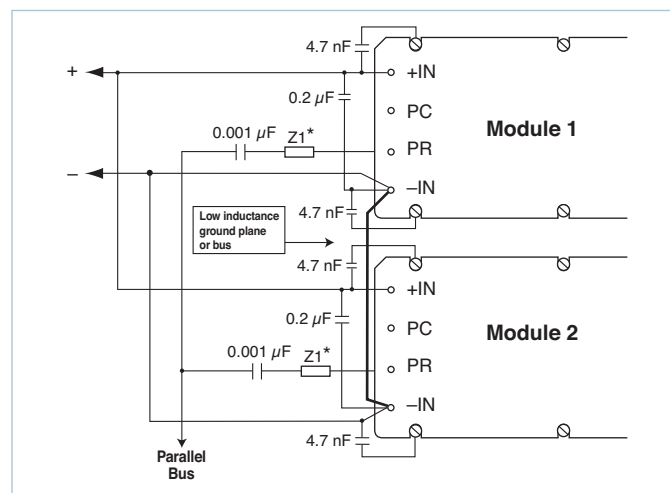

Figure 9 — AC coupled single-wire interface

* See Maxi, Mini, Micro Design Guide

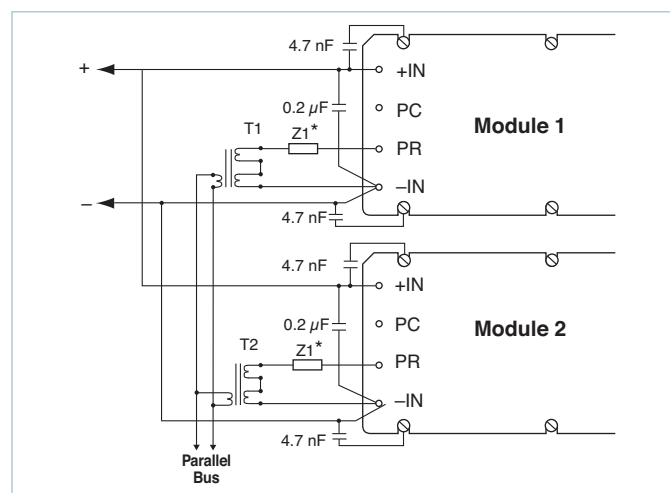
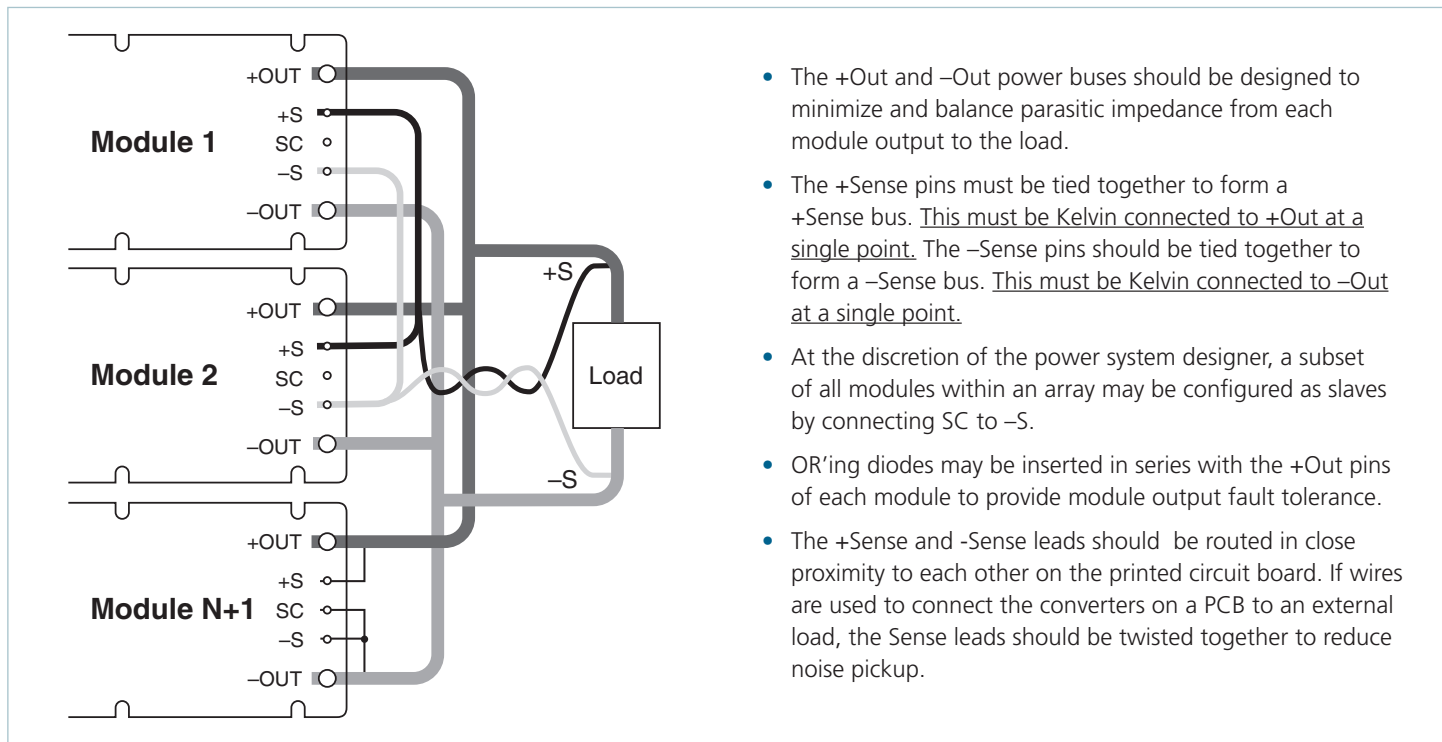

Figure 10 — Transformer-coupled interface.

Parallel Bus Output



- The +Out and –Out power buses should be designed to minimize and balance parasitic impedance from each module output to the load.
- The +Sense pins must be tied together to form a +Sense bus. This must be Kelvin connected to +Out at a single point. The –Sense pins should be tied together to form a –Sense bus. This must be Kelvin connected to –Out at a single point.
- At the discretion of the power system designer, a subset of all modules within an array may be configured as slaves by connecting SC to –S.
- OR’ing diodes may be inserted in series with the +Out pins of each module to provide module output fault tolerance.
- The +Sense and -Sense leads should be routed in close proximity to each other on the printed circuit board. If wires are used to connect the converters on a PCB to an external load, the Sense leads should be twisted together to reduce noise pickup.

Figure 11 — N+1 module array output connections

PIN STYLES*

Designator	Description	Finish	Notes
(None)	Short	Tin/Lead	Requires in-board, mounting
L	Long	Tin/Lead	On-board mounting for 0.065" boards
S	Short ModuMate	Gold	SurfMate or in-board socket mounting
N	Long ModuMate	Gold	On-board socket mounting
F	Short RoHS	Gold	Select for RoHS compliant in-board solder, socket, or SurfMate mounting
G	Long RoHS	Gold	Select for RoHS compliant on-board solder or socket mounting
K	Extra Long RoHS	Gold	Select for RoHS compliance on-board mounting for thicker PCBs (not intended for socket or Surfmate mounting)

* Pin style designator follows the "B" after the output power and precedes the baseplate designator.
 Ex. V110B12T200BN2 — Long ModuMate Pins

Mechanical Drawings

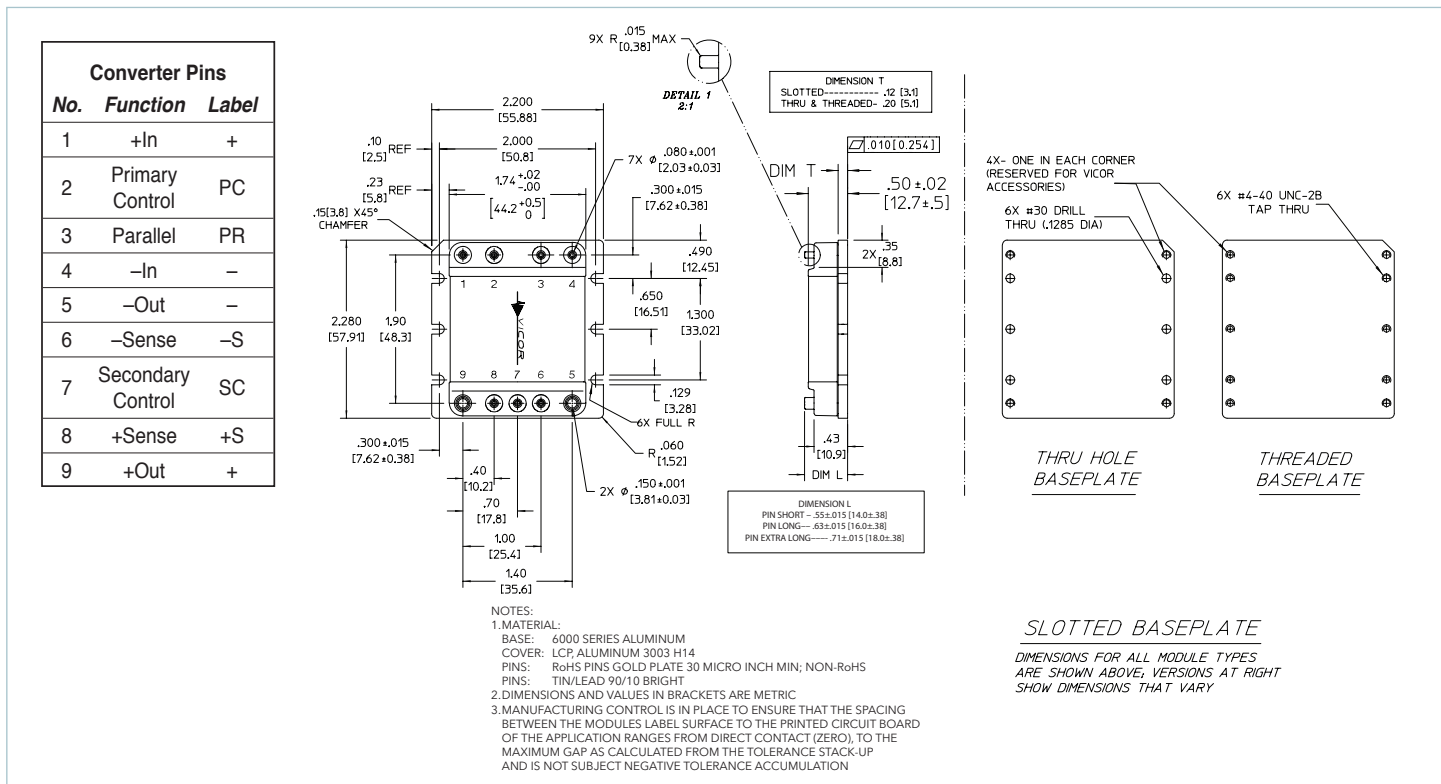

Figure 12 — Module outline

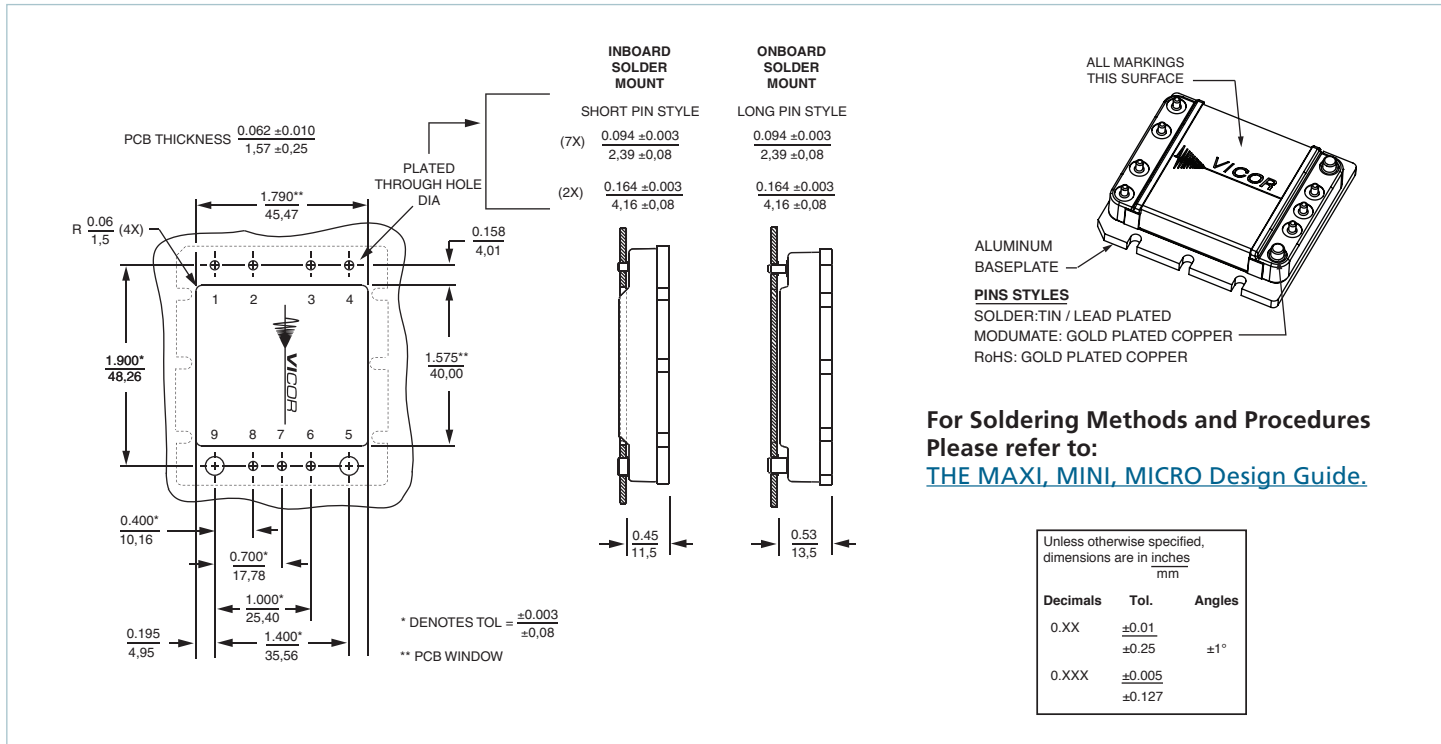

Figure 13 — PCB mounting specifications

Vicor's comprehensive line of power solutions includes high density AC-DC and DC-DC modules and accessory components, fully configurable AC-DC and DC-DC power supplies, and complete custom power systems.

Information furnished by Vicor is believed to be accurate and reliable. However, no responsibility is assumed by Vicor for its use. Vicor makes no representations or warranties with respect to the accuracy or completeness of the contents of this publication. Vicor reserves the right to make changes to any products, specifications, and product descriptions at any time without notice. Information published by Vicor has been checked and is believed to be accurate at the time it was printed; however, Vicor assumes no responsibility for inaccuracies. Testing and other quality controls are used to the extent Vicor deems necessary to support Vicor's product warranty. Except where mandated by government requirements, testing of all parameters of each product is not necessarily performed.

Specifications are subject to change without notice.

Vicor's Standard Terms and Conditions

All sales are subject to Vicor's Standard Terms and Conditions of Sale, which are available on Vicor's webpage or upon request.

Product Warranty

In Vicor's standard terms and conditions of sale, Vicor warrants that its products are free from non-conformity to its Standard Specifications (the "Express Limited Warranty"). This warranty is extended only to the original Buyer for the period expiring two (2) years after the date of shipment and is not transferable.

UNLESS OTHERWISE EXPRESSLY STATED IN A WRITTEN SALES AGREEMENT SIGNED BY A DULY AUTHORIZED VICOR SIGNATORY, VICOR DISCLAIMS ALL REPRESENTATIONS, LIABILITIES, AND WARRANTIES OF ANY KIND (WHETHER ARISING BY IMPLICATION OR BY OPERATION OF LAW) WITH RESPECT TO THE PRODUCTS, INCLUDING, WITHOUT LIMITATION, ANY WARRANTIES OR REPRESENTATIONS AS TO MERCHANTABILITY, FITNESS FOR PARTICULAR PURPOSE, INFRINGEMENT OF ANY PATENT, COPYRIGHT, OR OTHER INTELLECTUAL PROPERTY RIGHT, OR ANY OTHER MATTER.

This warranty does not extend to products subjected to misuse, accident, or improper application, maintenance, or storage. Vicor shall not be liable for collateral or consequential damage. Vicor disclaims any and all liability arising out of the application or use of any product or circuit and assumes no liability for applications assistance or buyer product design. Buyers are responsible for their products and applications using Vicor products and components. Prior to using or distributing any products that include Vicor components, buyers should provide adequate design, testing and operating safeguards.

Vicor will repair or replace defective products in accordance with its own best judgment. For service under this warranty, the buyer must contact Vicor to obtain a Return Material Authorization (RMA) number and shipping instructions. Products returned without prior authorization will be returned to the buyer. The buyer will pay all charges incurred in returning the product to the factory. Vicor will pay all reshipment charges if the product was defective within the terms of this warranty.

Life Support Policy

VICOR'S PRODUCTS ARE NOT AUTHORIZED FOR USE AS CRITICAL COMPONENTS IN LIFE SUPPORT DEVICES OR SYSTEMS WITHOUT THE EXPRESS PRIOR WRITTEN APPROVAL OF THE CHIEF EXECUTIVE OFFICER AND GENERAL COUNSEL OF VICOR CORPORATION. As used herein, life support devices or systems are devices which (a) are intended for surgical implant into the body, or (b) support or sustain life and whose failure to perform when properly used in accordance with instructions for use provided in the labeling can be reasonably expected to result in a significant injury to the user. A critical component is any component in a life support device or system whose failure to perform can be reasonably expected to cause the failure of the life support device or system or to affect its safety or effectiveness. Per Vicor Terms and Conditions of Sale, the user of Vicor products and components in life support applications assumes all risks of such use and indemnifies Vicor against all liability and damages.

Intellectual Property Notice

Vicor and its subsidiaries own Intellectual Property (including issued U.S. and Foreign Patents and pending patent applications) relating to the products described in this data sheet. No license, whether express, implied, or arising by estoppel or otherwise, to any intellectual property rights is granted by this document. Interested parties should contact Vicor's Intellectual Property Department.

Vicor Corporation

25 Frontage Road
Andover, MA, USA 01810
Tel: 800-735-6200
Fax: 978-475-6715

email

Customer Service: custserv@vicorpower.com
Technical Support: apps@vicorpower.com