

Excellent Integrated System Limited

Stocking Distributor

Click to view price, real time Inventory, Delivery & Lifecycle Information:

[Hammond Manufacturing](#)
[1551GBK](#)

For any questions, you can email us directly:

sales@integrated-circuit.com

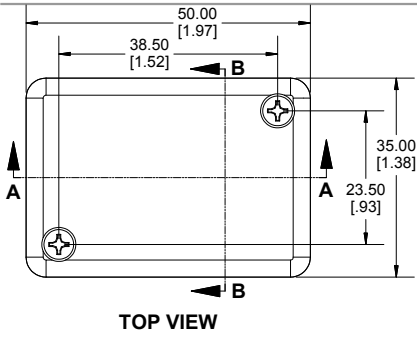

TOP VIEW

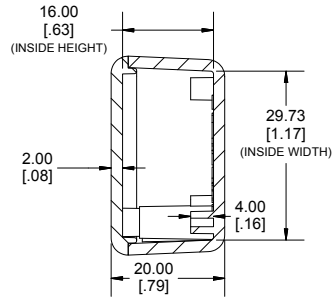

END VIEW SECTION B-B

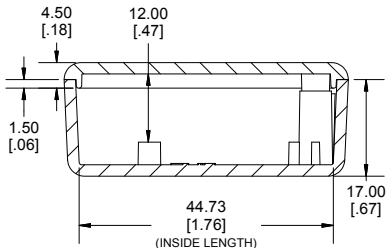
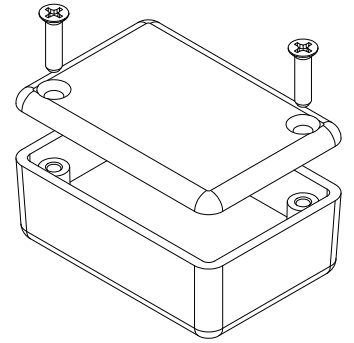

SIDE VIEW SECTION A-A

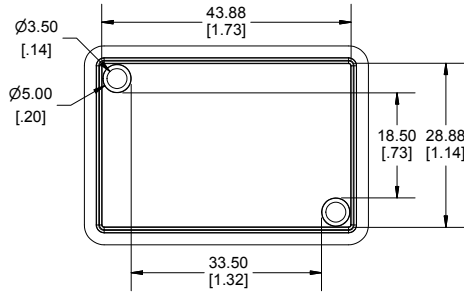

INSIDE LID

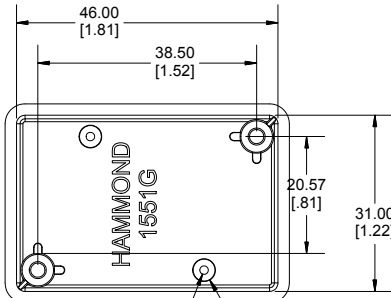

INSIDE BOX

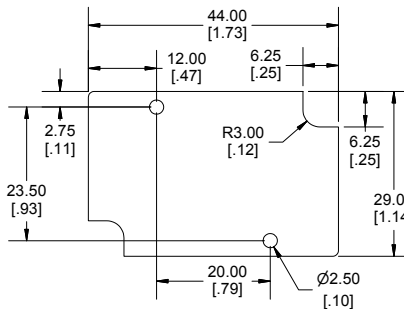

MAXIMUM P.C. BOARD SIZE

Enclosures can be Factory Modified (Milling, Drilling, Printing etc.)
Contact Factory mjm@hammondmfg.com for quotes
Solid models of this enclosure available in STEP or IGES.
(Part number and text placement/orientation on our products are subject to change, we do not recommend using them as a locating reference for modification purposes)

NOTE	
Purchased assembly includes box, lid, 2 cover screws.	
Enclosure molded from general purpose ABS Plastic.	
Other materials / colours available consult factory.	
Recommended Torque : (35-43) Ozf.in / (25-30) cN.m	
PART NUMBERS	
1551G Enclosure	
Black Enclosure - Ral 9011 - UL94 - HB	1551GBK
Gray Enclosure - RAL 7035 - UL94 - HB	1551GGY
Tranlucent Blue - UL94 - HB	1551GTBU
ACCESSORIES	
Black Cover Screws #4 X 1/2" Self-Tapping	1591TS100BK (Pkg 100)
Plated Cover Screws #4 X 1/2" Self-Tapping	1591TS100 (Pkg 100)
P.C. Board Screws	1551ATS50 (Pkg 50)
#2 x 3/16" self-Tapping (4.8mm)	1551ATS100 (Pkg 100)

HAMMOND MANUFACTURING

1551G

www.hammondmfg.com

Dimensions:
mm
[inches]