

Excellent Integrated System Limited

Stocking Distributor

Click to view price, real time Inventory, Delivery & Lifecycle Information:

[On-Shore Technology, Inc.](#)
[ED4100/2](#)

For any questions, you can email us directly:

sales@integrated-circuit.com

Ratings:
 Current 10A
 Voltage 300 V
 Wire Size 20-14AWG
 Test Voltage 2.0 kV

Rated Cross Section:
 Single Wire (solid) 2.5mm²
 Stranded Wire (flexible) on request
 Stranded Wire with Ferrules on request

Dimensions:
 Spacing 5.0mm
 PCB Hole Diameter 1.0mm
 Stripped Length 9.0mm

Materials:
 Insulating Material PA
 Flammability UL94V-0
 Temperature -30°C/+105°C
 Tension Spring Stainless Steel
 Contact Cu
 Color Slade Gray

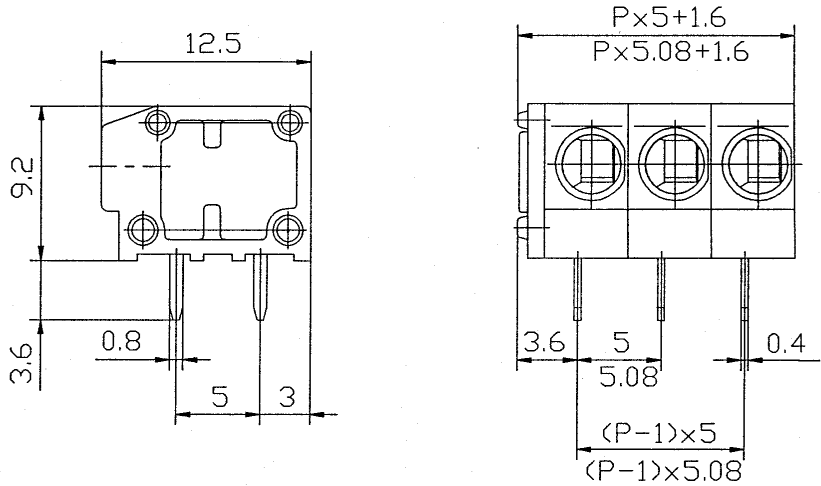

Part Number
ED(Z)4100/[*][*]
 * - NUMBER OF POSITIONS

Units	Drawing	Reviewed	Approved	Date
mm				3/23/99
				Sheet 1 of 1
				Rev. A