

## **Excellent Integrated System Limited**

Stocking Distributor

Click to view price, real time Inventory, Delivery & Lifecycle Information:

[Texas Instruments](#)

[TLV62065TDSGRQ1](#)

For any questions, you can email us directly:

[sales@integrated-circuit.com](mailto:sales@integrated-circuit.com)

## TLV62065-Q1 3-MHz 2-A Step-Down Converter in 2-mm x 2-mm WSON Package

### 1 Features

- Qualified for Automotive Applications
- AEC-Q100 Test Guidance With the Following Results:
  - Device Temperature Grade 2: –40°C to 105°C Ambient Operating Temperature Range
  - Device HBM ESD Classification Level 2
  - Device CDM ESD Classification Level C4B
- $V_{IN}$  Range from 2.9 to 5.5 V
- Up to 97% Efficiency
- Power-Save Mode or Fixed Frequency PWM Mode
- Output Voltage Accuracy in PWM Mode  $\pm 2\%$
- Output Capacitor Discharge Function
- Typical 18- $\mu$ A Quiescent Current
- 100% Duty Cycle for Lowest Dropout
- Available in a 2-mm x 2-mm x 0.75-mm WSON

### 2 Applications

- Automotive Infotainment and Cluster
- Advanced Driver Assistance System (ADAS)
- Automotive Display

### 3 Description

The TLV62065-Q1 device is a highly-efficient synchronous step-down DC-DC converter with adjustable output voltage. The device operates at a switching frequency of 3 MHz and provides up to 2 A of output current.

With an input voltage range of 2.9 to 5.5 V, the device is a perfect fit for power conversion from a 5-V or 3.3-V system supply rail. The TLV62065-Q1 device enters power-save mode operation at light-load currents to maintain high efficiency over the entire load current range. For low-noise applications, the TLV62065-Q1 device can be forced into fixed-frequency PWM mode by pulling the MODE pin high.

In the shutdown mode, the current consumption is reduced to less than 1  $\mu$ A and an internal circuit discharges the output capacitor.

The TLV62065-Q1 device operates with a 1- $\mu$ H inductor and 10- $\mu$ F output capacitor.

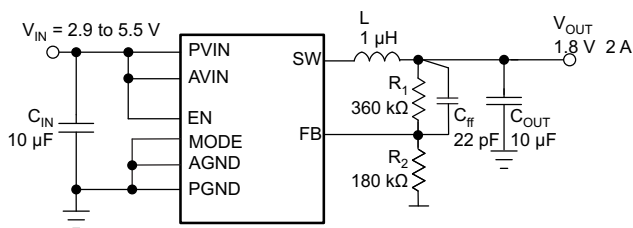
The TLV62065-Q1 device is available in a small 2-mm x 2-mm x 0.75-mm 8-pin WSON package.

#### Device Information<sup>(1)</sup>

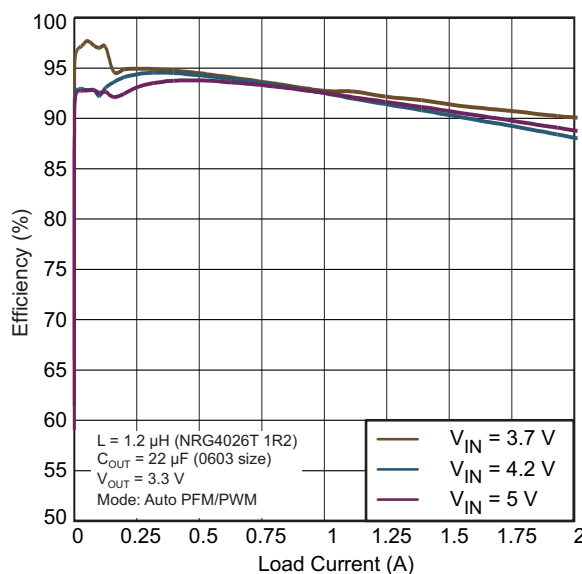
PART NUMBER	PACKAGE	BODY SIZE (NOM)
TLV62065-Q1	WSON (8)	2.00 mm x 2.00 mm

(1) For all available packages, see the orderable addendum at the end of the datasheet.

#### Typical Application Circuit



#### Efficiency vs. Load Current



**TLV62065-Q1**

SLVSB92B – JANUARY 2012 – REVISED JUNE 2015

www.ti.com

**Table of Contents**

<b>1 Features</b> .....	<b>1</b>	7.3 Feature Description .....	<b>12</b>
<b>2 Applications</b> .....	<b>1</b>	7.4 Device Functional Modes .....	<b>13</b>
<b>3 Description</b> .....	<b>1</b>	<b>8 Application and Implementation</b> .....	<b>15</b>
<b>4 Revision History</b> .....	<b>2</b>	8.1 Application Information .....	<b>15</b>
<b>5 Pin Configuration and Functions</b> .....	<b>3</b>	8.2 Typical Application .....	<b>15</b>
<b>6 Specifications</b> .....	<b>4</b>	<b>9 Power Supply Recommendations</b> .....	<b>18</b>
6.1 Absolute Maximum Ratings .....	<b>4</b>	<b>10 Layout</b> .....	<b>18</b>
6.2 ESD Ratings .....	<b>4</b>	10.1 Layout Guidelines .....	<b>18</b>
6.3 Recommended Operating Conditions .....	<b>4</b>	10.2 Layout Example .....	<b>19</b>
6.4 Thermal Information .....	<b>4</b>	<b>11 Device and Documentation Support</b> .....	<b>19</b>
6.5 Electrical Characteristics .....	<b>5</b>	11.1 Documentation Support .....	<b>19</b>
6.6 Switching Characteristics .....	<b>6</b>	11.2 Community Resource .....	<b>19</b>
6.7 Typical Characteristics .....	<b>6</b>	11.3 Trademarks .....	<b>19</b>
<b>7 Detailed Description</b> .....	<b>11</b>	11.4 Electrostatic Discharge Caution .....	<b>20</b>
7.1 Overview .....	<b>11</b>	11.5 Glossary .....	<b>20</b>
7.2 Functional Block Diagram .....	<b>11</b>	<b>12 Mechanical, Packaging, and Orderable Information</b> .....	<b>20</b>

**4 Revision History**

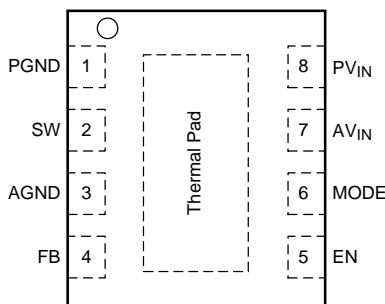
NOTE: Page numbers for previous revisions may differ from page numbers in the current version.

<b>Changes from Revision A (March 2012) to Revision B</b>	<b>Page</b>
• Changed the <i>Description</i> section to state that the TLV62065-Q1 device has an adjustable output voltage. ....	<b>1</b>
• Added the <i>Pin Configuration and Functions</i> section, <i>ESD Ratings</i> table, <i>Feature Description</i> section, <i>Device Functional Modes</i> , <i>Application and Implementation</i> section, <i>Power Supply Recommendations</i> section, <i>Layout</i> section, <i>Device and Documentation Support</i> section, and <i>Mechanical, Packaging, and Orderable Information</i> section .....	<b>1</b>
• Changed the <i>Thermal Information</i> values .....	<b>4</b>
• Deleted the <i>Parameter Measurement Information</i> section because the circuit is similar to the application circuit in the <i>Typical Application</i> section .....	<b>11</b>
• Changed $f_c$ to $f_z$ and $R_2$ to $R_1$ in the feed-forward capacitor equations in the <i>Output Voltage Setting</i> section .....	<b>15</b>
• Deleted the <i>List of Inductors</i> and <i>List of Capacitors</i> tables .....	<b>16</b>

<b>Changes from Original (January 2012) to Revision A</b>	<b>Page</b>
• Update automotive qualification description and add temperature grade .....	<b>1</b>
• Update Absolute Maximum Ratings .....	<b>4</b>
• Update Electrical Characteristics - Shutdown current max rating .....	<b>5</b>

## 5 Pin Configuration and Functions

DSG Package  
 8-Pin WSON With Exposed Thermal Pad  
 Top View



Pin Functions

PIN		TYPE	DESCRIPTION
NAME	NO.		
AGND	3	IN	Analog GND supply pin for the control circuit.
AV <sub>IN</sub>	7	IN	Analog V <sub>IN</sub> power supply for the control circuit. This pin must be connected to the PV <sub>IN</sub> pin and the input capacitor.
EN	5	IN	EN is the enable pin of the device. Pulling this pin low forces the device into shutdown mode. Pulling this pin high enables the device. This pin must be terminated.
FB	4	IN	Feedback pin for the internal regulation loop. Connect the external resistor divider to this pin. In the case of fixed output voltage option, connect this pin directly to the output capacitor.
MODE	6	IN	When the MODE pin is high, the device is forced to operate in fixed-frequency PWM mode. When the MODE pin is low, the device enters the power-save mode with automatic transition from PFM mode to fixed-frequency PWM mode. This pin must be terminated.
PGND	1	PWR	GND supply pin for the output stage
PV <sub>IN</sub>	8	PWR	V <sub>IN</sub> power-supply pin for the output stage
SW	2	OUT	SW is the switch pin and is connected to the internal MOSFET switches. Connect the external inductor between this pin and the output capacitor.
Thermal pad		—	For good thermal performance, this pad must be soldered to the land pattern on the PCB. This pad should be used as device GND.

**TLV62065-Q1**

SLVSB92B – JANUARY 2012 – REVISED JUNE 2015

[www.ti.com](http://www.ti.com)

## 6 Specifications

### 6.1 Absolute Maximum Ratings

 over operating free-air temperature range (unless otherwise noted)<sup>(1)</sup>

		MIN	MAX	UNIT
Voltage range <sup>(2)</sup>	AVIN, PVIN	−0.3	7	V
	EN, MODE, FB	−0.3	$V_{IN} + 0.3 < 7$	
	SW	−0.3	7	
Current (source)	Peak output	Internally limited		A
Junction temperature, T <sub>J</sub>		−40	140	°C
Storage temperature, T <sub>stg</sub>		−65	150	°C

(1) Stresses beyond those listed under *Absolute Maximum Ratings* may cause permanent damage to the device. These are stress ratings only, and functional operation of the device at these or any other conditions beyond those indicated under *Recommended Operating Conditions* is not implied. Exposure to absolute-maximum-rated conditions for extended periods may affect device reliability.

(2) All voltage values are with respect to the network ground pin.

### 6.2 ESD Ratings

		VALUE	UNIT	
V <sub>(ESD)</sub> Electrostatic discharge	Human body model (HBM), per AEC Q100-002 <sup>(1)</sup>	±2000	V	
	Charged device model (CDM), per AEC Q100-011	Corner pins (1, 4, 5, and 8)		±750
		Other pins		±500

(1) AEC Q100-002 indicates HBM stressing is done in accordance with the ANSI/ESDA/JEDEC JS-001 specification.

### 6.3 Recommended Operating Conditions

		MIN	NOM	MAX	UNIT
AV <sub>IN</sub> , PV <sub>IN</sub>	Supply voltage	2.9		5.5	V
	Output current capability			2000	mA
	Output voltage range for adjustable voltage	0.8		V <sub>IN</sub>	V
L	Effective inductance range	0.7	1	1.6	μH
C <sub>OUT</sub>	Effective output-capacitance range	4.5	10	22	μF
T <sub>A</sub>	Operating ambient temperature <sup>(1)</sup>	−40		105	°C
T <sub>J</sub>	Operating junction temperature	−40		140	°C

(1) In applications where high power dissipation, poor package thermal resistance, or both are present, the maximum ambient temperature may have to be derated. Maximum ambient temperature (T<sub>A(max)</sub>) is dependent on the maximum operating junction temperature (T<sub>J(max)</sub>), the maximum power dissipation of the device in the application (P<sub>D(max)</sub>), and the junction-to-ambient thermal resistance of the device or package in the application (R<sub>θJA</sub>), as given by the following equation:  $T_{A(max)} = T_{J(max)} - (R_{\theta JA} \times P_{D(max)})$

### 6.4 Thermal Information

THERMAL METRIC <sup>(1)</sup>		TLV62065-Q1	UNIT
		DSG (WSON)	
		8 PINS	
R <sub>θJA</sub>	Junction-to-ambient thermal resistance	58.1	°C/W
R <sub>θJC(top)</sub>	Junction-to-case(top) thermal resistance	67.4	°C/W
R <sub>θJB</sub>	Junction-to-board thermal resistance	29.2	°C/W
ψ <sub>JT</sub>	Junction-to-top characterization parameter	1.1	°C/W
ψ <sub>JB</sub>	Junction-to-board characterization parameter	29.8	°C/W
R <sub>θJC(bot)</sub>	Junction-to-case(bottom) thermal resistance	7.2	°C/W

(1) For more information about traditional and new thermal metrics, see the *Semiconductor and IC Package Thermal Metrics* application report, [SPRA953](#).

## 6.5 Electrical Characteristics

Over full operating ambient temperature range, typical values are at  $T_A = 25^\circ\text{C}$ . Unless otherwise noted, specifications apply for condition  $V_{IN} = EN = 3.6\text{ V}$ . External components  $C_{IN} = 10\ \mu\text{F}$  0603,  $C_{OUT} = 10\ \mu\text{F}$  0603,  $L = 1\ \mu\text{H}$

PARAMETER		TEST CONDITIONS	MIN	TYP	MAX	UNIT
<b>SUPPLY</b>						
$V_{IN}$	Input voltage range		2.9		5.5	V
$I_Q$	Operating quiescent current	$I_{OUT} = 0\text{ mA}$ , device operating in PFM mode and not device not switching		18		$\mu\text{A}$
$I_{SD}$	Shutdown current	$EN = \text{GND}$ , current into AVIN and PVIN combined		0.1	5	$\mu\text{A}$
$V_{UVLO}$	Undervoltage lockout threshold	Falling	1.73	1.78	1.83	V
		Rising	1.9	1.95	1.99	
<b>ENABLE, MODE</b>						
$V_{IH}$	High-level input voltage	$2.9\text{ V} \leq V_{IN} \leq 5.5\text{ V}$	1		5.5	V
$V_{IL}$	Low-level input voltage	$2.9\text{ V} \leq V_{IN} \leq 5.5\text{ V}$	0		0.4	V
$I_{IN}$	Input bias current	$EN, \text{MODE}$ tied to GND or AVIN		0.01	1	$\mu\text{A}$
<b>POWER SWITCH</b>						
$r_{DS(on)}$	High-side MOSFET on-resistance	$V_{IN} = 3.6\text{ V}^{(1)}$		120	180	$\text{m}\Omega$
		$V_{IN} = 5\text{ V}^{(1)}$		95	150	
$r_{DS(on)}$	Low-side MOSFET on-resistance	$V_{IN} = 3.6\text{ V}^{(1)}$		90	130	$\text{m}\Omega$
		$V_{IN} = 5\text{ V}^{(1)}$		75	100	
$I_{LIMF}$	Forward current limit MOSFET high-side and low-side	$3\text{ V} \leq V_{IN} \leq 3.6\text{ V}$	2300	2750		mA
$T_{SD}$	Thermal shutdown	Increasing junction temperature		150		$^\circ\text{C}$
	Thermal shutdown hysteresis	Decreasing junction temperature		10		
<b>OUTPUT</b>						
$V_{ref}$	Reference voltage			600		mV
$V_{FB(PWM)}$	Feedback voltage, PWM mode	PWM operation, $\text{MODE} = V_{IN}$ , $2.9\text{ V} \leq V_{IN} \leq 5.5\text{ V}$ , 0-mA load	-2%	0%	2%	
$V_{FB(PFM)}$	Feedback voltage, PFM mode, voltage positioning	Device in PFM mode, voltage positioning active <sup>(2)</sup>		1%		
$V_{FB}$	Load regulation			-0.5		%/A
	Line regulation			0		%/V
$R_{(Discharge)}$	Internal discharge resistor	Activated with $EN = \text{GND}$ , $2.9\text{ V} \leq V_{IN} \leq 5.5\text{ V}$ , $0.8\text{ V} \leq V_{OUT} \leq 3.6\text{ V}$		200		$\Omega$

(1) Maximum value applies for  $T_J = 85^\circ\text{C}$ .

(2) In PFM mode, the internal reference voltage is set to typ.  $1.01 \times V_{ref}$ . See the [Application and Implementation](#) section.

**TLV62065-Q1**

SLVSB92B – JANUARY 2012 – REVISED JUNE 2015

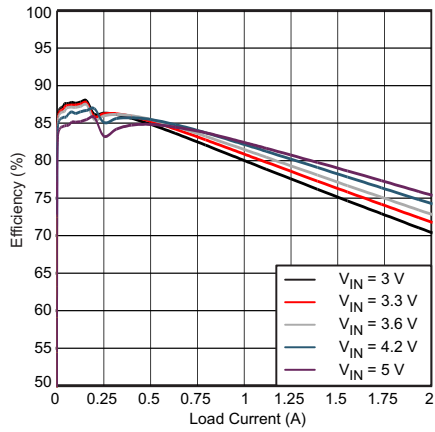
[www.ti.com](http://www.ti.com)
**6.6 Switching Characteristics**

over operating free-air temperature range (unless otherwise noted)

PARAMETER	TEST CONDITIONS	MIN	TYP	MAX	UNIT
<b>OSCILLATOR</b>					
$f_{SW}$ Oscillator frequency	$2.9\text{ V} \leq V_{IN} \leq 5.5\text{ V}$	2.6	3	3.4	MHz
<b>OUTPUT</b>					
$t_{START}$ Startup time	Time from active EN to reach 95% of $V_{OUT}$		500		$\mu\text{s}$

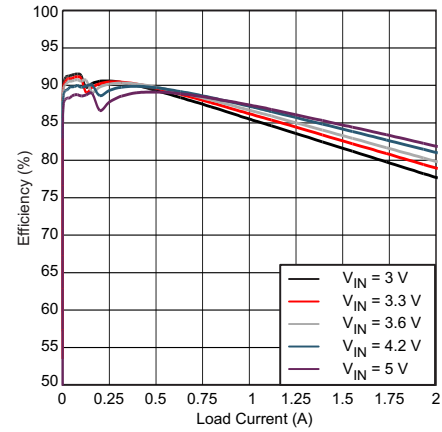
**6.7 Typical Characteristics**
**Table 1. Table of Graphs**

		FIGURE
$\eta$ Efficiency	Load Current, $V_{OUT} = 1.2\text{ V}$ , Auto PFM/PWM Mode, Linear Scale	<a href="#">Figure 1</a>
	Load Current, $V_{OUT} = 1.8\text{ V}$ , Auto PFM/PWM Mode, Linear Scale	<a href="#">Figure 2</a>
	Load Current, $V_{OUT} = 3.3\text{ V}$ , PFM/PWM Mode, Linear Scale	<a href="#">Figure 3</a>
	Load Current, $V_{OUT} = 1.8\text{ V}$ , Auto PFM/PWM Mode vs. Forced PWM Mode, Logarithmic Scale	<a href="#">Figure 4</a>
Output Voltage Accuracy	Load Current, $V_{OUT} = 1.8\text{ V}$ , Auto PFM/PWM Mode	<a href="#">Figure 5</a>
	Load Current, $V_{OUT} = 1.8\text{ V}$ , Forced PWM Mode	<a href="#">Figure 6</a>
Shutdown Current	Input Voltage and Ambient Temperature	<a href="#">Figure 7</a>
Quiescent Current	Input Voltage	<a href="#">Figure 8</a>
Oscillator Frequency	Input Voltage	<a href="#">Figure 9</a>
Static Drain-Source On-State Resistance	Input Voltage, Low-Side Switch	<a href="#">Figure 10</a>
	Input Voltage, High-Side Switch	<a href="#">Figure 11</a>
$R_{DISCHARGE}$	Input Voltage vs. $V_{OUT}$	<a href="#">Figure 12</a>
Typical Operation	PWM Mode, $V_{IN} = 3.6\text{ V}$ , $V_{OUT} = 1.8\text{ V}$ , 500 mA, $L = 1.2\text{ }\mu\text{H}$ , $C_{OUT} = 10\text{ }\mu\text{F}$	<a href="#">Figure 13</a>
	PFM Mode, $V_{IN} = 3.6\text{ V}$ , $V_{OUT} = 1.8\text{ V}$ , 20 mA, $L = 1.2\text{ }\mu\text{H}$ , $C_{OUT} = 10\text{ }\mu\text{F}$	<a href="#">Figure 14</a>
Load Transient	PWM Mode, $V_{IN} = 3.6\text{ V}$ , $V_{OUT} = 1.2\text{ V}$ , 0.2 mA to 1 A	<a href="#">Figure 15</a>
	PFM Mode, $V_{IN} = 3.6\text{ V}$ , $V_{OUT} = 1.2\text{ V}$ , 20 mA to 250 mA	<a href="#">Figure 16</a>
	$V_{IN} = 3.6\text{ V}$ , $V_{OUT} = 1.8\text{ V}$ , 200 mA to 1500 mA	<a href="#">Figure 17</a>
Line Transient	PWM Mode, $V_{IN} = 3.6\text{ V}$ to 4.2 V, $V_{OUT} = 1.8\text{ V}$ , 500 mA	<a href="#">Figure 18</a>
	PFM Mode, $V_{IN} = 3.6\text{ V}$ to 4.2 V, $V_{OUT} = 1.8\text{ V}$ , 500 mA	<a href="#">Figure 19</a>
Startup into Load	$V_{IN} = 3.6\text{ V}$ , $V_{OUT} = 1.8\text{ V}$ , Load = 2.2- $\Omega$	<a href="#">Figure 20</a>
Output Discharge	$V_{IN} = 3.6\text{ V}$ , $V_{OUT} = 1.8\text{ V}$ , No Load	<a href="#">Figure 21</a>



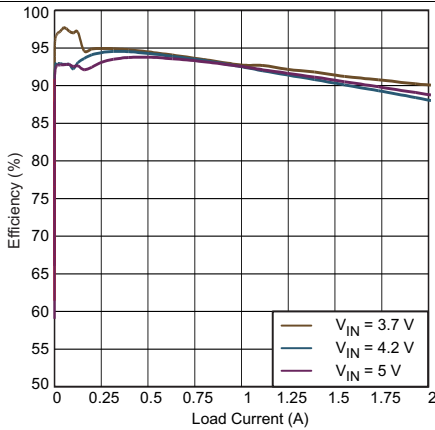
$V_{OUT} = 1.2\text{ V}$  Linear Scale  
 $L = 1.2\ \mu\text{H}$  (NRG4026T 1R2)  $C_{OUT} = 10\ \mu\text{F}$  (0603 size)

**Figure 1. Efficiency vs Load Current  
Auto PFM and PWM MODE**



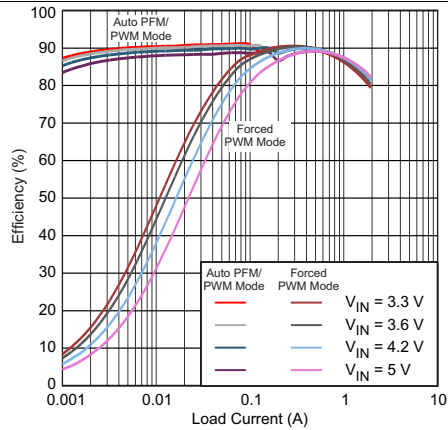
$V_{OUT} = 1.8\text{ V}$  Linear Scale  
 $L = 1.2\ \mu\text{H}$  (NRG4026T 1R2)  $C_{OUT} = 10\ \mu\text{F}$  (0603 size)

**Figure 2. Efficiency vs Load Current  
Auto PFM and PWM MODE**



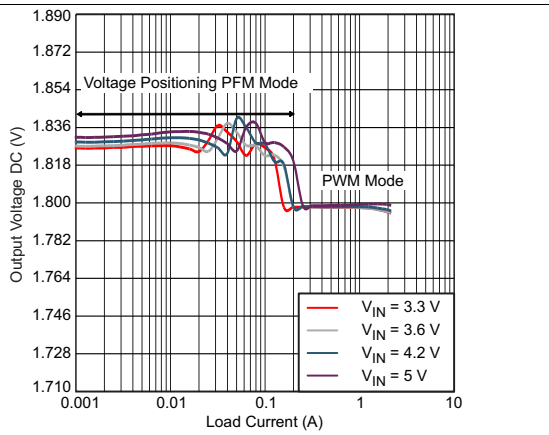
$V_{OUT} = 3.3\text{ V}$  Linear Scale  
 $L = 1.2\ \mu\text{H}$  (NRG4026T 1R2)  $C_{OUT} = 22\ \mu\text{F}$  (0603 size)

**Figure 3. Efficiency vs Load Current  
Auto PFM and PWM MODE**



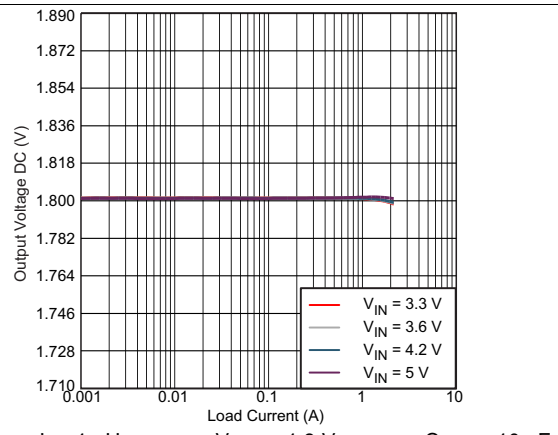
$V_{OUT} = 1.8\text{ V}$  Logarithmic Scale  
 $C_{OUT} = 10\ \mu\text{F}$  (0603 size)  $L = 1.2\ \mu\text{H}$  (NRG4026T 1R2)

**Figure 4. Efficiency vs Load Current  
Auto PFM and PWM Mode vs. Forced PWM Mode**



$L = 1\ \mu\text{H}$   $V_{OUT} = 1.8\text{ V}$   $C_{OUT} = 10\ \mu\text{F}$

**Figure 5. Output Voltage Accuracy vs Load Current  
Auto PFM and PWM MODE**



$L = 1\ \mu\text{H}$   $V_{OUT} = 1.8\text{ V}$   $C_{OUT} = 10\ \mu\text{F}$

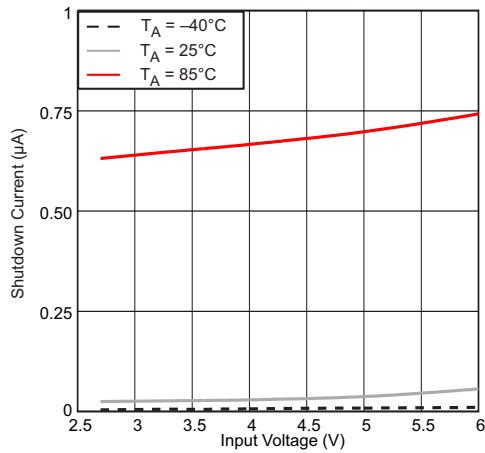
**Figure 6. Output Voltage Accuracy vs Load Current  
Forced PWM MODE**



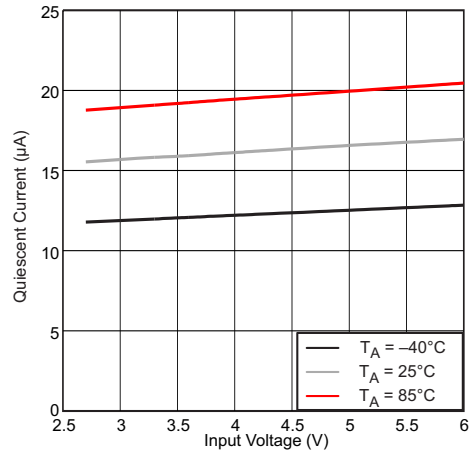
**TLV62065-Q1**

SLVSB92B – JANUARY 2012 – REVISED JUNE 2015

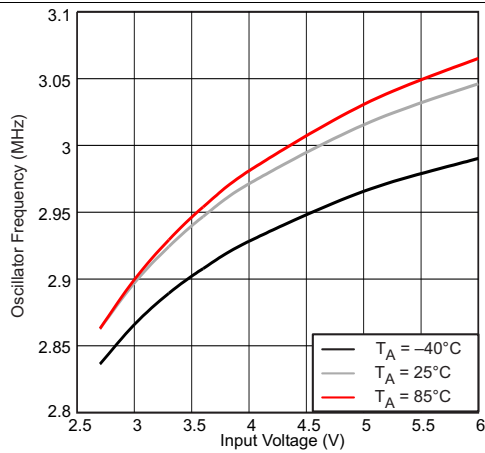
www.ti.com



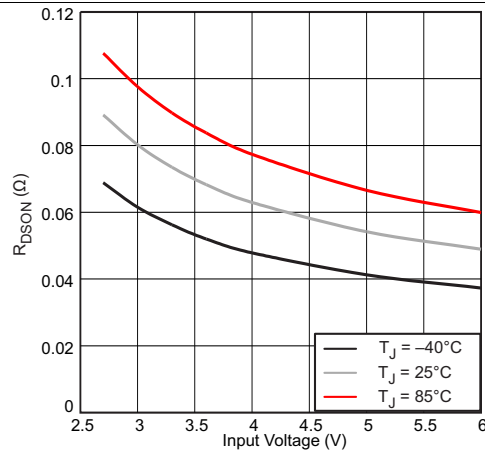
**Figure 7. Shutdown Current vs Input Voltage and Ambient Temperature**



**Figure 8. Quiescent Current vs Input Voltage**

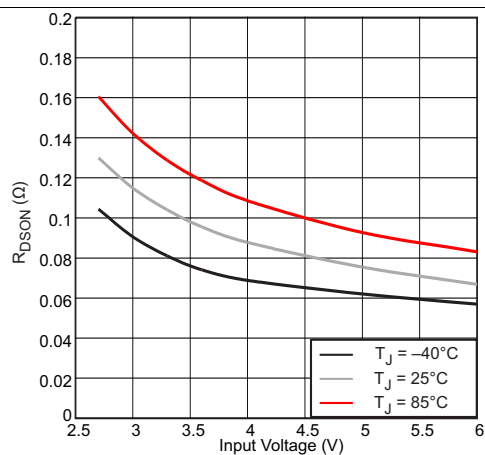


**Figure 9. Oscillator Frequency vs Input Voltage**



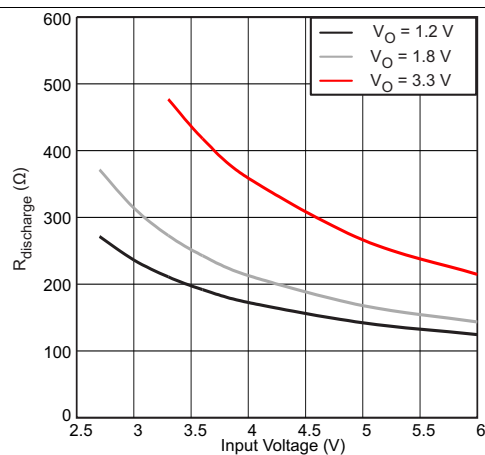
Low-Side Switch

**Figure 10. Static Drain-Source On-State Resistance vs Input Voltage**

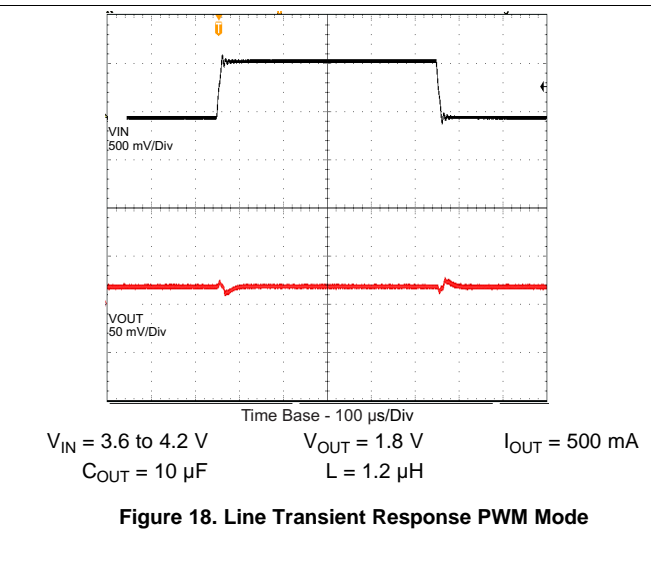
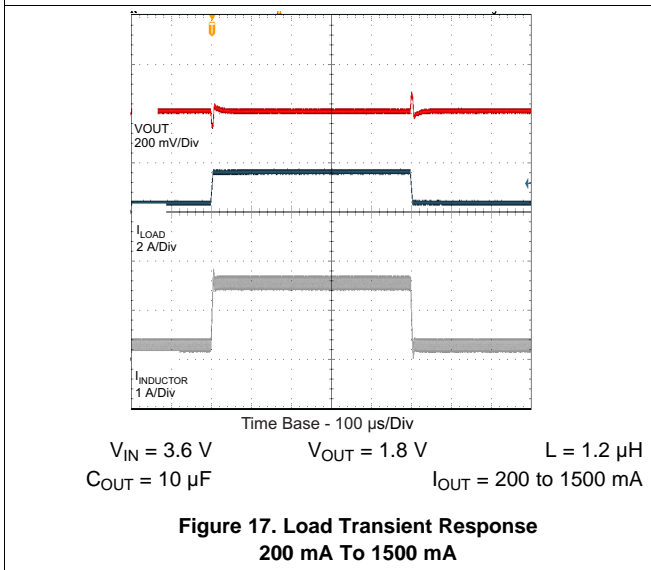
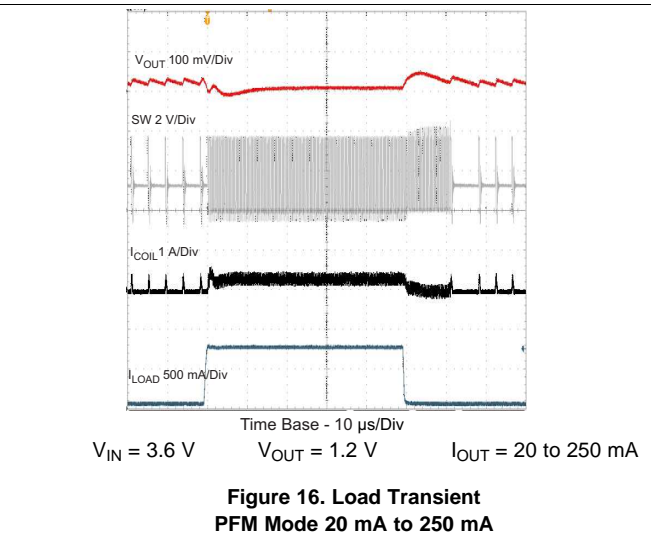
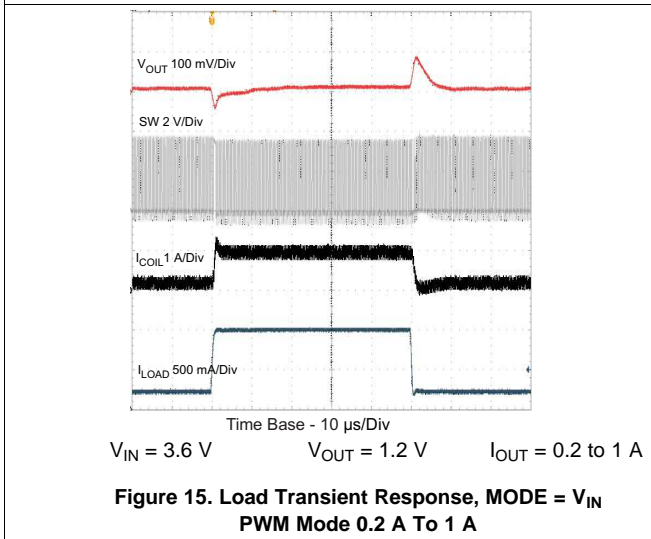
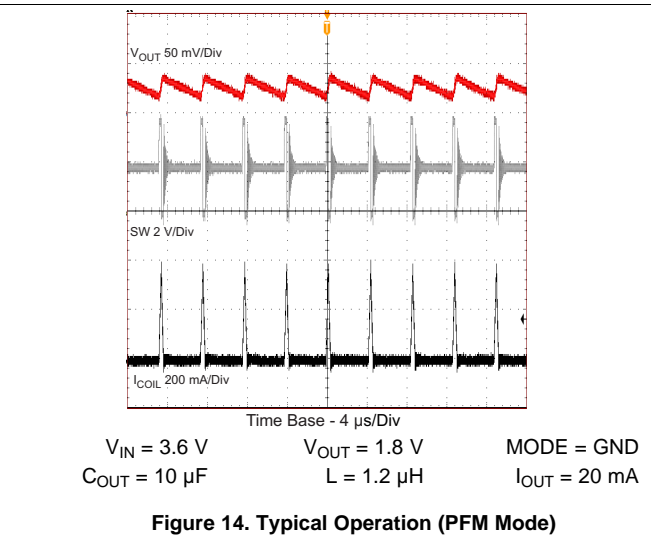
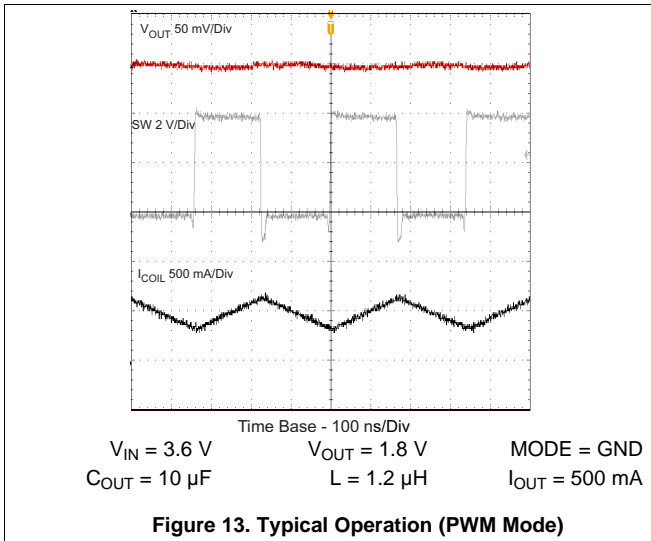


High-Side Switch

**Figure 11. Static Drain-Source On-State Resistance vs Input Voltage**



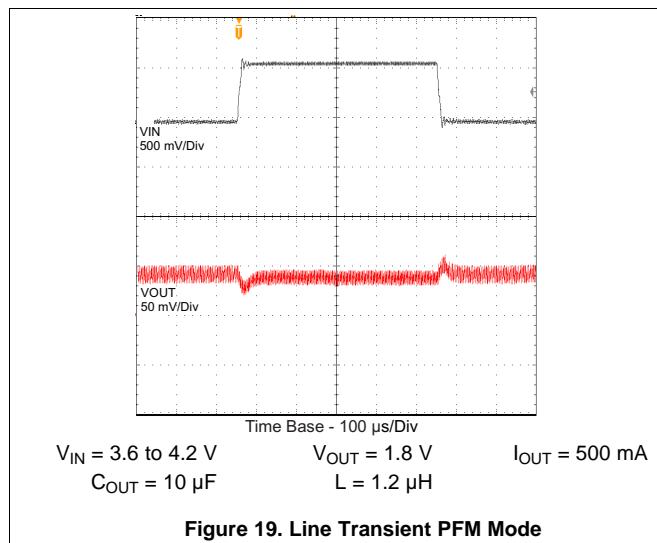
**Figure 12. RDISCHARGE vs Input Voltage**



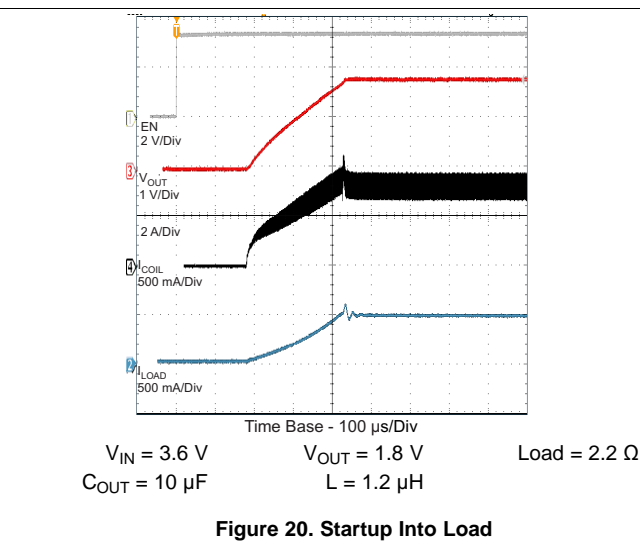
**TLV62065-Q1**

SLVSB92B – JANUARY 2012 – REVISED JUNE 2015

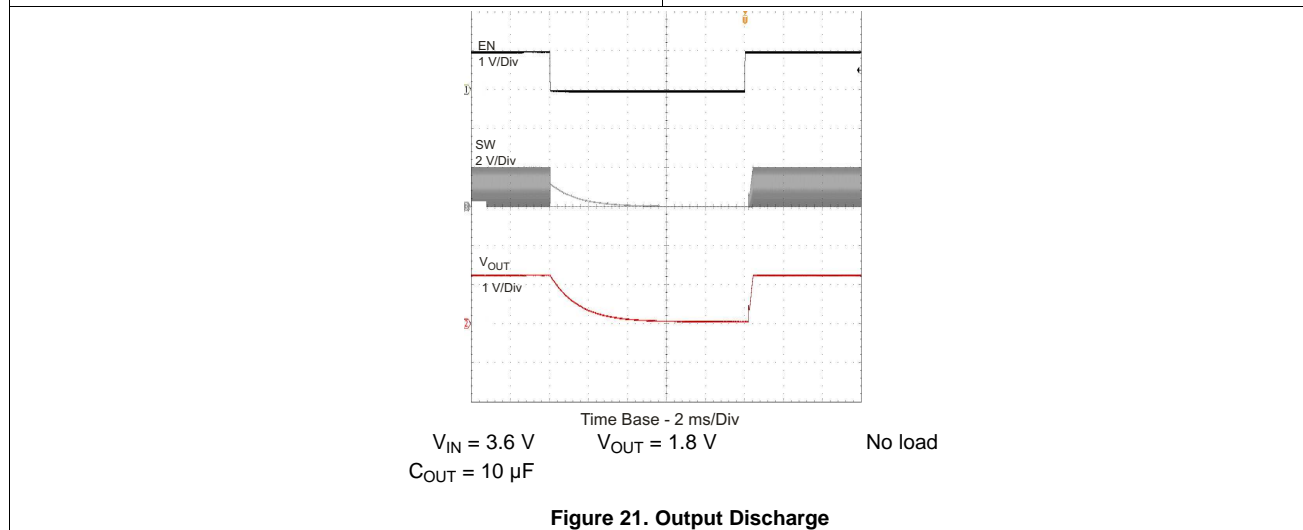
www.ti.com



**Figure 19. Line Transient PFM Mode**



**Figure 20. Startup Into Load**



**Figure 21. Output Discharge**

## 7 Detailed Description

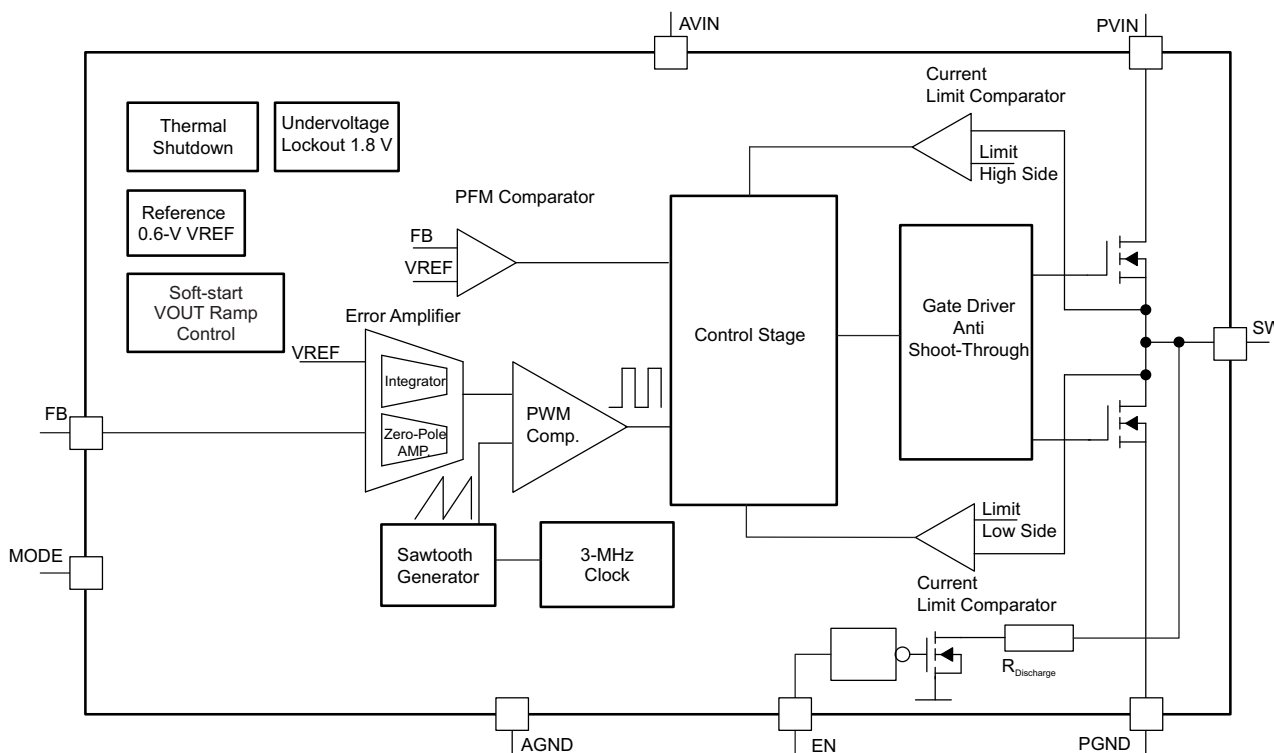
### 7.1 Overview

The TLV62065-Q1 step-down converter operates with a typical 3-MHz fixed-frequency pulse-width modulation (PWM) at moderate to heavy load currents. At light load currents, the converter can automatically enter power-save mode, and then operates in pulse-frequency mode (PFM).

During PWM operation, the converter uses a unique fast-response voltage-mode controller scheme with input voltage feed-forward to achieve good line and load regulation, allowing the use of small ceramic input and output capacitors. At the beginning of each clock cycle initiated by the clock signal, the high-side MOSFET switch is turned on. The current now flows from the input capacitor through the high-side MOSFET switch through the inductor to the output capacitor and load. During this phase, the current ramps up until the PWM comparator trips and the control logic turns off the switch. The current-limit comparator also turns off the switch in case the current-limit of the high-side MOSFET switch is exceeded. After a dead time preventing shoot-through current, the low-side MOSFET rectifier is turned on and the inductor current ramps down. The current now flows from the inductor to the output capacitor and to the load. The current returns back to the inductor through the low-side MOSFET rectifier.

The next cycle is initiated by the clock signal again turning off the low-side MOSFET rectifier and turning on the high-side MOSFET switch.

### 7.2 Functional Block Diagram



**TLV62065-Q1**

SLVSB92B – JANUARY 2012 – REVISED JUNE 2015

[www.ti.com](http://www.ti.com)
**7.3 Feature Description**
**7.3.1 Enable**

The device is enabled by setting the EN pin high. At first, the internal reference is activated and the internal analog circuits are settled. Afterwards, the soft start is activated and the output voltage is ramped up. The output voltages reaches 95% of the nominal value within  $t_{START}$  of typically 500  $\mu$ s after the device has been enabled. The EN input can be used to control power sequencing in a system with various DC-DC converters. To drive the EN pin high and get a sequencing of supply rails, connect the EN pin to the output of another converter. With EN = GND, the device enters shutdown mode. In this mode, all circuits are disabled and the SW pin is connected to PGND through an internal resistor to discharge the output.

**7.3.2 Mode Selection**

The MODE pin allows mode selection between forced PWM mode and power-save mode.

Connecting this pin to GND enables the power-save mode with automatic transition between PWM and PFM mode. Pulling the MODE pin high forces the converter to operate in fixed-frequency PWM mode even at light load currents which allows simple filtering of the switching frequency for noise-sensitive applications. In this mode, the efficiency is lower compared to the power-save mode during light loads.

The condition of the MODE pin can be changed during operation and allows efficient power management by adjusting the operation mode of the converter to the specific system requirements.

**7.3.3 Soft-Start Functionality**

The TLV62065-Q1 device has an internal soft-start circuit that controls the ramp-up of the output voltage. When the converter is enabled and the input voltage is above the undervoltage lockout threshold,  $V_{UVLO}$ , the output voltage ramps up from 5% to 95% of the nominal value within a  $t_{Ramp}$  of 250  $\mu$ s (typical).

This ramping limits the inrush current in the converter during startup and prevents possible input-voltage drops when a battery or high-impedance power source is used.

During soft start, the switch current limit is reduced to 1/3 of the nominal value,  $I_{LIMF}$ , until the output voltage reaches 1/3 of the nominal value. When the output voltage trips this threshold, the device operates with the nominal current-limit,  $I_{LIMF}$ .

**7.3.4 Internal Current-Limit and Foldback Current-Limit For Short-Circuit Protection**

During normal operation, the high-side and low-side MOSFET switches are protected by the current limits,  $I_{LIMF}$ . When the high-side MOSFET switch reaches the current limit, it is turned off and the low-side MOSFET switch is turned on. The high-side MOSFET switch can only turn on again when the current in the low-side MOSFET switch decreases below the current-limit,  $I_{LIMF}$ . The device is capable of providing peak inductor currents up to the internal-current limit  $I_{LIMF}$ .

As soon as the switch-current limits are hit and the output voltage falls below 1/3 of the nominal output voltage because of an overload or short-circuit condition, the foldback current limit is enabled. In this case, the switch-current limit is reduced to 1/3 of the nominal value,  $I_{LIMF}$ .

Because the short-circuit protection is enabled during startup, the device does not deliver more than 1/3 of the nominal current-limit,  $I_{LIMF}$ , until the output voltage exceeds 1/3 of the nominal output voltage. This must be considered when a load which acts as a current sink is connected to the output of the converter.

## Feature Description (continued)

### 7.3.5 100% Duty Cycle Low-Dropout Operation

The device begins to enter 100% duty cycle mode as the input voltage comes close to the nominal output voltage. In order to maintain the output voltage, the high-side MOSFET switch is turned on 100% for one or more cycles.

With further decreasing  $V_{IN}$ , the high-side MOSFET switch is turned on completely. In this case, the converter offers a low input-to-output voltage differential. This differential voltage is particularly useful in battery-powered applications to achieve longest operation time by taking full advantage of the whole battery voltage range.

The minimum input voltage to maintain regulation depends on the load current and output voltage, and is calculated using Equation 1.

$$V_{INmin} = V_{Omax} + I_{Omax} \times (R_{DS(on)max} + R_L)$$

where

- $I_{Omax}$  = maximum output current
- $R_{DS(on)max}$  = maximum P-channel switch  $R_{DS(on)}$
- $R_L$  = DC resistance of the inductor
- $V_{Omax}$  = nominal output voltage plus maximum output voltage tolerance (1)

### 7.3.6 Undervoltage Lockout

The undervoltage lockout (UVLO) circuit prevents the device from malfunctioning at low input voltages and from excessive discharge of the battery. The UVLO circuit disables the output stage of the converter once the falling  $V_{IN}$  trips the undervoltage lockout threshold  $V_{UVLO}$ . The undervoltage lockout threshold  $V_{UVLO}$  for falling  $V_{IN}$  is typically 1.78 V. The device begins operation when the rising  $V_{IN}$  trips the undervoltage lockout threshold  $V_{UVLO}$  again at 1.95 V (typical).

### 7.3.7 Output Capacitor Discharge

With  $EN = GND$ , the device enters shutdown mode and disables all internal circuits. An internal resistor connects the SW pin is to PGND to discharge the output capacitor. This feature ensures startup with a discharged output capacitor when the converter is enabled again and prevents a *floating* charge on the output capacitor. The output voltage ramps up monotonic, starting from 0 V.

### 7.3.8 Thermal Shutdown

As soon as the junction temperature,  $T_J$ , exceeds 150°C (typical) the device goes into thermal shutdown. In this mode, the high-side and low-side MOSFETs are turned off. The device continues operation with a soft-start when the junction temperature falls below the thermal shutdown hysteresis.

## 7.4 Device Functional Modes

### 7.4.1 Power Save Mode

Pulling the TLV62065-Q1 MODE pin low enables power-save mode. If the load current decreases, the converter enters power-save mode operation automatically. In power-save mode, the converter skips switching and operates with reduced frequency in the PFM mode with a minimum quiescent current to maintain high efficiency. The converter positions the output voltage 1% (typical) above the nominal output voltage. This voltage-positioning feature minimizes voltage drops caused by a sudden load step.

The transition from PWM mode to PFM mode occurs when the inductor current in the low-side MOSFET switch becomes zero, which indicates discontinuous conduction mode.

In power-save mode, a PFM comparator monitors the output voltage. As the output voltage falls below the PFM comparator threshold of  $V_{OUTnominal} + 1\%$ , the device begins a PFM current pulse. For this pulse, the high-side MOSFET switch turns on and the inductor current ramps up. After the on-time expires, the switch is turned off and the low-side MOSFET switch is turned on until the inductor current becomes zero.

The converter effectively delivers a current to the output capacitor and the load. If the load is below the delivered current, the output voltage rises. If the output voltage is equal to or higher than the PFM comparator threshold, the device stops switching and enters a sleep mode with 18- $\mu$ A current consumption (typical).

**TLV62065-Q1**

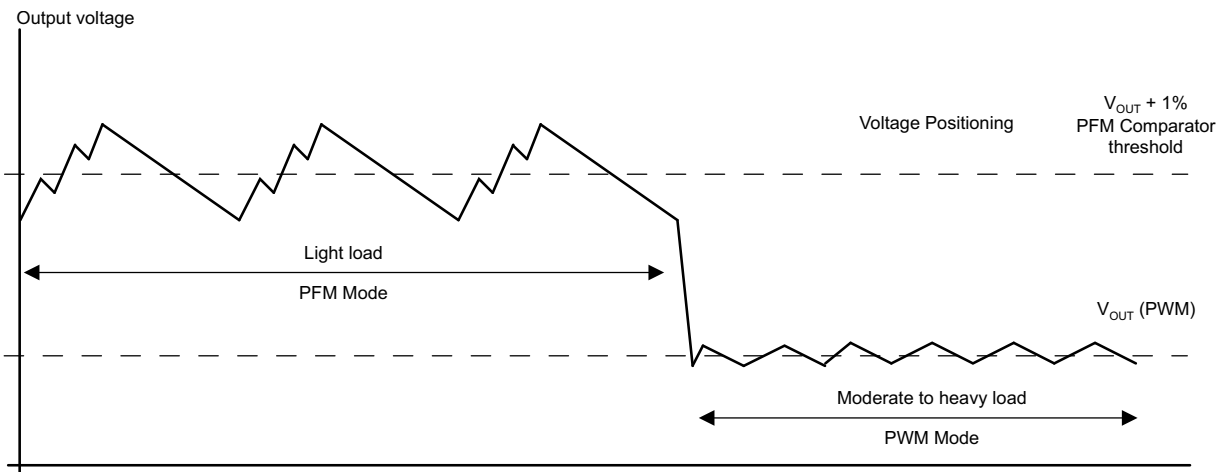
SLVSB92B – JANUARY 2012 – REVISED JUNE 2015

www.ti.com

**Device Functional Modes (continued)**

In case the output voltage is still below the PFM comparator threshold, further PFM current pulses are generated until the PFM comparator threshold is reached. The converter begins switching again when the output voltage drops below the PFM comparator threshold because of the load current.

The device leaves PFM mode and goes to PWM mode in case the output current can no longer be supported in PFM mode.



**Figure 22. Power Save Mode Operation With Automatic Mode Transition**



## 8 Application and Implementation

### NOTE

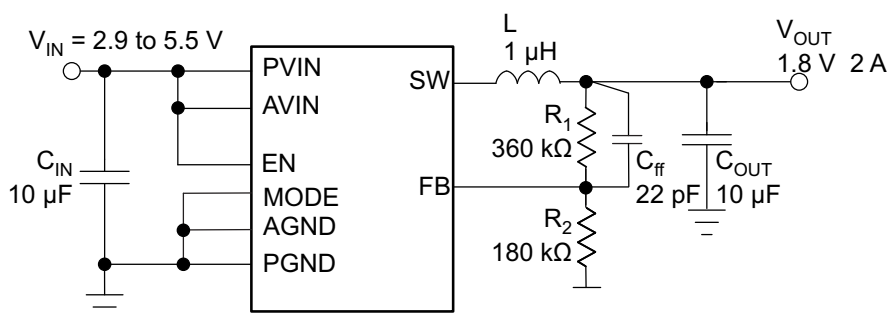
Information in the following applications sections is not part of the TI component specification, and TI does not warrant its accuracy or completeness. TI's customers are responsible for determining suitability of components for their purposes. Customers should validate and test their design implementation to confirm system functionality.

### 8.1 Application Information

The TLV62065-Q1 device is a highly efficient, synchronous step-down, DC-DC converter with an adjustable output voltage and an output current of up to 2 A. The device can be used in buck converter applications with an input range from 2.9 to 5.5 V.

### 8.2 Typical Application

The typical application circuit (see [Figure 23](#)) is optimized for an output voltage of 1.8 V and a load current of 2 A maximum for an input voltage from 2.9 to 5.5 V.



**Figure 23. TLV62065-Q1 1.8-V Adjustable Output Voltage Configuration**

#### 8.2.1 Design Requirements

The input voltage for this device must be from 2.9 V to 5.5 V. The output voltage must be set using an external voltage divider. The internal compensation network of the device is optimized for an LC output filter that is composed of a 1-µH inductor and a 10-µF ceramic capacitor with a suitable external feed-forward capacitor calculated based on the voltage divider resistor. The [Recommended Operating Conditions](#) table specifies the allowed range for input voltages, output voltages, output current, inductance, and capacitance. The values listed in this table must be followed when designing the regulator. Low-ESR ceramic capacitors should be used at the input and output for better filtering and ripple performance. The [Detailed Design Procedure](#) section provides the necessary equations and guidelines for selecting external components for this regulator.

#### 8.2.2 Detailed Design Procedure

##### 8.2.2.1 Output Voltage Setting

Use [Equation 2](#) to calculate the output voltage.

$$V_{OUT} = V_{REF} \times \left( 1 + \frac{R_1}{R_2} \right) \quad (2)$$

A typical internal reference voltage,  $V_{REF}$ , is 0.6 V.

To minimize the current through the feedback divider network,  $R_2$  should be within the range of 120 kΩ to 360 kΩ. To keep the network robust against noise the sum of  $R_1$  and  $R_2$  should not exceed approximately 1 MΩ. An external feed-forward capacitor,  $C_{ff}$ , is required for optimum regulation performance. Lower resistor values can be used.  $R_1$  and  $C_{ff}$  place a zero in the loop. Use [Equation 4](#) to calculate the value of  $C_{ff}$ .



**TLV62065-Q1**

SLVSB92B – JANUARY 2012 – REVISED JUNE 2015

[www.ti.com](http://www.ti.com)
**Typical Application (continued)**

$$f_z = \frac{1}{2 \times \pi \times R_1 \times C_{ff}} = 25 \text{ kHz} \quad (3)$$

$$C_{ff} = \frac{1}{2 \times \pi \times R_1 \times 25 \text{ kHz}} \quad (4)$$

**8.2.2.2 Output Filter Design (inductor And Output Capacitor)**

The internal compensation network of the TLV62065-Q1 device is optimized for an LC output filter with a corner frequency that is calculated with [Equation 5](#)

$$f_c = \frac{1}{2 \times \pi \times \sqrt{(1 \mu\text{H} \times 10 \mu\text{F})}} = 50 \text{ kHz} \quad (5)$$

The device operates with nominal inductors of 1  $\mu\text{H}$  to 1.2  $\mu\text{H}$  and with 10  $\mu\text{F}$  to 22  $\mu\text{F}$  small X5R and X7R ceramic capacitors. The device is optimized for a 1- $\mu\text{H}$  inductor and 10- $\mu\text{F}$  output capacitor.

**8.2.2.2.1 Inductor Selection**

The inductor value has a direct effect on the ripple current. The selected inductor must be rated for the DC resistance and saturation current. The inductor ripple current ( $\Delta I_L$ ) decreases with higher inductance and increases with higher  $V_{IN}$  or  $V_{OUT}$ .

Use [Equation 6](#) to calculate the maximum inductor current in PWM mode under static load conditions. The saturation current of the inductor should be rated higher than the maximum inductor current as calculated with [Equation 7](#). This value is recommended because during heavy load transients the inductor current rises above the calculated value.

$$\Delta I_L = V_{OUT} \times \frac{1 - \frac{V_{OUT}}{V_{IN}}}{L \times f}$$

where

- $\Delta I_L$  = Peak-to-peak inductor ripple current
  - L = Inductor value
  - f = Switching frequency (3 MHz typical)
- (6)

$$I_{Lmax} = I_{OUTmax} + \frac{\Delta I_L}{2}$$

where

- $I_{Lmax}$  = Maximum inductor current
- (7)

A more conservative approach is to select the inductor current rating just for the switch-current limit  $I_{LIMF}$  of the converter.

The total losses of the coil have a strong impact on the efficiency of the DC-DC conversion and consist of both the losses in the DC resistance  $R_{(DC)}$  and the following frequency-dependent components:

- The losses in the core material (magnetic hysteresis loss, especially at high switching frequencies)
- Additional losses in the conductor from the skin effect (current displacement at high frequencies)
- Magnetic field losses of the neighboring windings (proximity effect)
- Radiation losses

## Typical Application (continued)

### 8.2.2.2.2 Output Capacitor Selection

The advanced fast-response voltage-mode control scheme of the TLV62065-Q1 device allows the use of tiny ceramic capacitors. Ceramic capacitors with low ESR values have the lowest output-voltage ripple and are recommended. The output capacitor requires either an X7R or X5R dielectric. Y5V- and Z5U-dielectric capacitors, aside from a wide variation in capacitance over temperature, become resistive at high frequencies and may not be used. For most applications, a nominal 10- $\mu$ F or 22- $\mu$ F capacitor is suitable. In small ceramic capacitors, the DC-bias effect decreases the effective capacitance. Therefore a 22- $\mu$ F capacitor can be used for output voltages higher than 2 V.

In case additional ceramic capacitors in the supplied system are connected to the output of the DC-DC converter, the output capacitor  $C_{OUT}$  must be decreased in order not to exceed the recommended effective capacitance range. In this case, a loop-stability analysis must be performed as described in the [Checking Loop Stability](#) section.

Use [Equation 8](#) to calculate the RMS ripple current at the nominal load current and while the device is in PWM mode.

$$I_{RMSOut} = V_{OUT} \times \frac{1 - \frac{V_{OUT}}{V_{IN}}}{L \times f} \times \frac{1}{2 \times \sqrt{3}} \quad (8)$$

### 8.2.2.2.3 Input Capacitor Selection

Because of the nature of the buck converter having a pulsating input current, a low-ESR input capacitor is required for best input voltage filtering and minimizing interference with other circuits caused by high input voltage spikes. For most applications a 10- $\mu$ F ceramic capacitor is recommended. The input capacitor can be increased without any limit for better input voltage filtering.

Take care when using only small ceramic input capacitors. When a ceramic capacitor is used at the input and the power is being supplied through long wires, such as from a wall adapter, a load step at the output or  $V_{IN}$  step on the input can induce ringing at the  $V_{IN}$  pin. This ringing can couple to the output and be mistaken as loop instability, or could even damage the part by exceeding the maximum ratings.

### 8.2.2.3 Checking Loop Stability

The first step of circuit and stability evaluation is to look at the following signals from a steady-state perspective:

- Switching node, SW
- Inductor current,  $I_L$
- Output ripple voltage,  $V_{OUT(AC)}$

These signals are the basic signals that must be measured when evaluating a switching converter. When the switching waveform shows large duty cycle jitter, or the output voltage or inductor current shows oscillations, the regulation loop may be unstable. This instability is often a result of board layout, wrong L-C output filter combinations, or both. As a next step in the evaluation of the regulation loop, the transient response of the load is tested. During the time between the application of the load transient and the turnon of the P-channel MOSFET, the output capacitor must supply all of the current required by the load.  $V_{OUT}$  immediately shifts by an amount equal to  $\Delta I_{(LOAD)} \times ESR$ , where ESR is the effective series resistance of  $C_{OUT}$ .  $\Delta I_{(LOAD)}$  begins to charge or discharge  $C_O$ , generating a feedback error signal used by the regulator to return  $V_{OUT}$  to its steady-state value. The results are most easily interpreted when the device operates in PWM mode at medium-to-high load currents.

During this recovery time,  $V_{OUT}$  can be monitored for settling time, overshoot, or ringing; that helps evaluate stability of the converter. Without any ringing, the loop has usually more than 45° of phase margin.

## TLV62065-Q1

SLVSB92B – JANUARY 2012 – REVISED JUNE 2015

www.ti.com

### Typical Application (continued)

#### 8.2.3 Application Curves

For the application curves, see the graphs listed in [Table 2](#).

**Table 2. Table of Graphs**

		FIGURE
Output Voltage Accuracy	Load Current, $V_{OUT} = 1.8\text{ V}$ , Auto PFM/PWM Mode	<a href="#">Figure 5</a>
	Load Current, $V_{OUT} = 1.8\text{ V}$ , Forced PWM Mode	<a href="#">Figure 6</a>

## 9 Power Supply Recommendations

The TLV62065-Q1 device is designed to operate from an input voltage up to 5.5 V. For the input pins (PVIN and AVIN), a small ceramic capacitor with a typical value of 10  $\mu\text{F}$  is recommended for most applications. Capacitance derating for aging, temperature, and DC bias must be taken into account while determining the capacitor value.

## 10 Layout

### 10.1 Layout Guidelines

As for all switching power supplies, the layout is an important step in the design. Proper function of the device demands careful attention to PCB layout. Care must be taken in board layout to get the specified performance. If the layout is not carefully done, the regulator could show poor line regulator, load regulation or both and have stability issues as well as EMI and thermal problems. Providing a low-inductance, low-impedance ground path is critical. Therefore, use wide and short traces for the main current paths. The input capacitor as well as the inductor and output capacitor should be placed as close as possible to the IC pins.

Connect the AGND and PGND pins of the device to the thermal pad land of the PCB and use this pad as a star point. To minimize the effects of ground noise use a common power node (PGND), and a different node (AGND) for the signal. The FB divider network should be connected directly to the output capacitor and the FB line must be routed away from noisy components and traces (for example, the SW line).

Because of the small package of this converter and the overall small solution size, the thermal performance of the PCB layout is important. For good thermal performance, PCB design of at least four layers is recommended. The thermal pad of the IC must be soldered on the power pad area on the PCB to achieve proper thermal connection. Additionally, for good thermal performance, the thermal pad on the PCB must be connected to an inner GND plane with sufficient via connections.

## 10.2 Layout Example

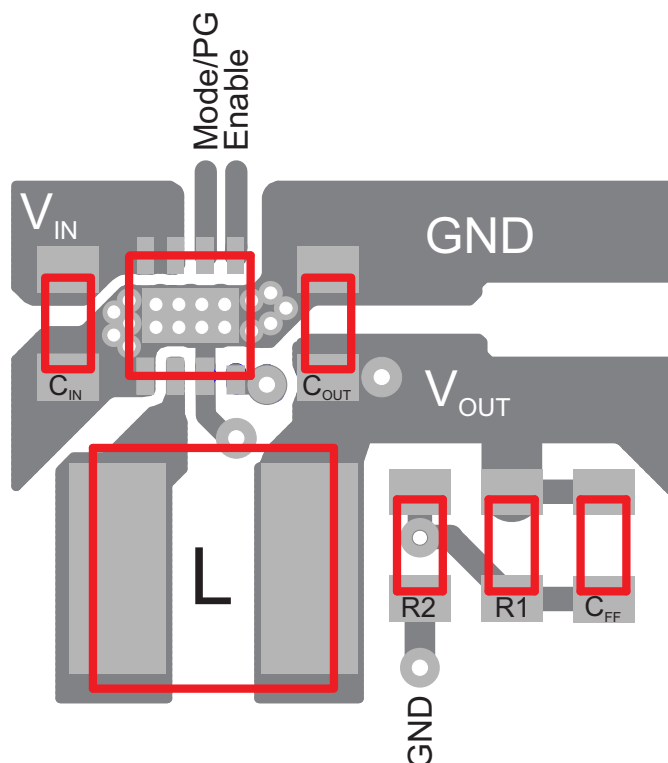


Figure 24. PCB Layout

## 11 Device and Documentation Support

### 11.1 Documentation Support

#### 11.1.1 Related Documentation

For related documentation see the following:

[TLV62065EVM-719 User's Guide \(SLVU424\)](#)

### 11.2 Community Resource

The following links connect to TI community resources. Linked contents are provided "AS IS" by the respective contributors. They do not constitute TI specifications and do not necessarily reflect TI's views; see TI's [Terms of Use](#).

**TI E2E™ Online Community** *TI's Engineer-to-Engineer (E2E) Community*. Created to foster collaboration among engineers. At e2e.ti.com, you can ask questions, share knowledge, explore ideas and help solve problems with fellow engineers.

**Design Support** *TI's Design Support* Quickly find helpful E2E forums along with design support tools and contact information for technical support.

### 11.3 Trademarks

E2E is a trademark of Texas Instruments.

All other trademarks are the property of their respective owners.

**TLV62065-Q1**

SLVSB92B – JANUARY 2012 – REVISED JUNE 2015

[www.ti.com](http://www.ti.com)**11.4 Electrostatic Discharge Caution**

These devices have limited built-in ESD protection. The leads should be shorted together or the device placed in conductive foam during storage or handling to prevent electrostatic damage to the MOS gates.

**11.5 Glossary**[SLYZ022](#) — *TI Glossary*.

This glossary lists and explains terms, acronyms, and definitions.

**12 Mechanical, Packaging, and Orderable Information**

The following pages include mechanical, packaging, and orderable information. This information is the most current data available for the designated devices. This data is subject to change without notice and revision of this document. For browser-based versions of this data sheet, refer to the left-hand navigation.



PACKAGING INFORMATION

Orderable Device	Status (1)	Package Type	Package Drawing	Pins	Package Qty	Eco Plan (2)	Lead/Ball Finish (6)	MSL Peak Temp (3)	Op Temp (°C)	Device Marking (4/5)	Samples
TLV62065TDSGRQ1	ACTIVE	WS0N	DSG	8	3000	Green (RoHS & no Sb/Br)	CU NIPDAU	Level-2-260C-1 YEAR	-40 to 105	SCD	

(1) The marketing status values are defined as follows:

**ACTIVE:** Product device recommended for new designs.

**LIFEBUY:** TI has announced that the device will be discontinued, and a lifetime-buy period is in effect.

**NRND:** Not recommended for new designs. Device is in production to support existing customers, but TI does not recommend using this part in a new design.

**PREVIEW:** Device has been announced but is not in production. Samples may or may not be available.

**OBSELETE:** TI has discontinued the production of the device.

(2) Eco Plan - The planned eco-friendly classification: Pb-Free (RoHS), Pb-Free (RoHS Exempt), or Green (RoHS & no Sb/Br) - please check <http://www.ti.com/productcontent> for the latest availability information and additional product content details.

**TBD:** The Pb-Free/Green conversion plan has not been defined.

**Pb-Free (RoHS):** TI's terms "Lead-Free" or "Pb-Free" mean semiconductor products that are compatible with the current RoHS requirements for all 6 substances, including the requirement that lead not exceed 0.1% by weight in homogeneous materials. Where designed to be soldered at high temperatures, TI Pb-Free products are suitable for use in specified lead-free processes.

**Pb-Free (RoHS Exempt):** This component has a RoHS exemption for either 1) lead-based flip-chip solder bumps used between the die and package, or 2) lead-based die adhesive used between the die and leadframe. The component is otherwise considered Pb-Free (RoHS compatible) as defined above.

**Green (RoHS & no Sb/Br):** TI defines "Green" to mean Pb-Free (RoHS compatible), and free of Bromine (Br) and Antimony (Sb) based flame retardants (Br or Sb do not exceed 0.1% by weight in homogeneous material)

(3) MSL, Peak Temp. - The Moisture Sensitivity Level rating according to the JEDEC industry standard classifications, and peak solder temperature.

(4) There may be additional marking, which relates to the logo, the lot trace code information, or the environmental category on the device.

(5) Multiple Device Markings will be inside parentheses. Only one Device Marking contained in parentheses and separated by a "-" will appear on a device. If a line is indented then it is a continuation of the previous line and the two combined represent the entire Device Marking for that device.

(6) Lead/Ball Finish - Orderable Devices may have multiple material finish options. Finish options are separated by a vertical ruled line. Lead/Ball Finish values may wrap to two lines if the finish value exceeds the maximum column width.

**Important Information and Disclaimer:** The information provided on this page represents TI's knowledge and belief as of the date that it is provided. TI bases its knowledge and belief on information provided by third parties, and makes no representation or warranty as to the accuracy of such information. Efforts are underway to better integrate information from third parties. TI has taken and continues to take reasonable steps to provide representative and accurate information but may not have conducted destructive testing or chemical analysis on incoming materials and chemicals. TI and TI suppliers consider certain information to be proprietary, and thus CAS numbers and other limited information may not be available for release.

In no event shall TI's liability arising out of such information exceed the total purchase price of the TI part(s) at issue in this document sold by TI to Customer on an annual basis.



**Distributor of Texas Instruments: Excellent Integrated System Limited**

Datasheet of TLV62065TDSGRQ1 - IC REG BUCK ADJ 2A SYNC 8WSON

Contact us: [sales@integrated-circuit.com](mailto:sales@integrated-circuit.com) Website: [www.integrated-circuit.com](http://www.integrated-circuit.com)

**PACKAGE OPTION ADDENDUM**

---

[www.ti.com](http://www.ti.com)

14-Aug-2014

---

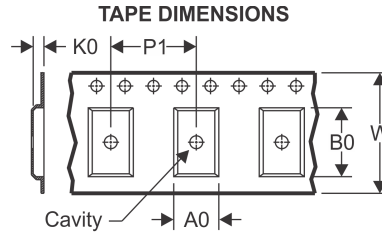
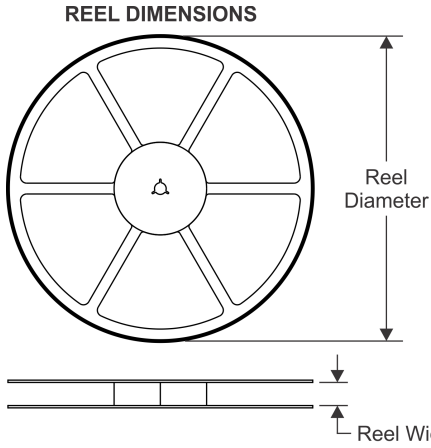
**OTHER QUALIFIED VERSIONS OF TLV62065-Q1 :**

- Catalog: [TLV62065](#)

**NOTE: Qualified Version Definitions:**

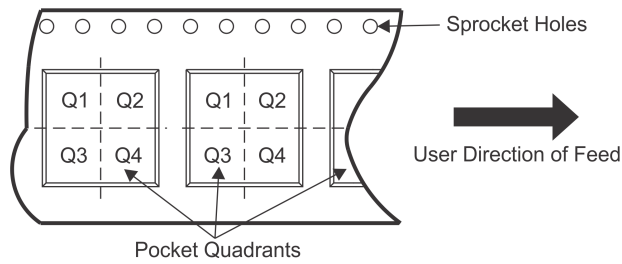
- Catalog - TI's standard catalog product

**TAPE AND REEL INFORMATION**



A0	Dimension designed to accommodate the component width
B0	Dimension designed to accommodate the component length
K0	Dimension designed to accommodate the component thickness
W	Overall width of the carrier tape
P1	Pitch between successive cavity centers

**QUADRANT ASSIGNMENTS FOR PIN 1 ORIENTATION IN TAPE**

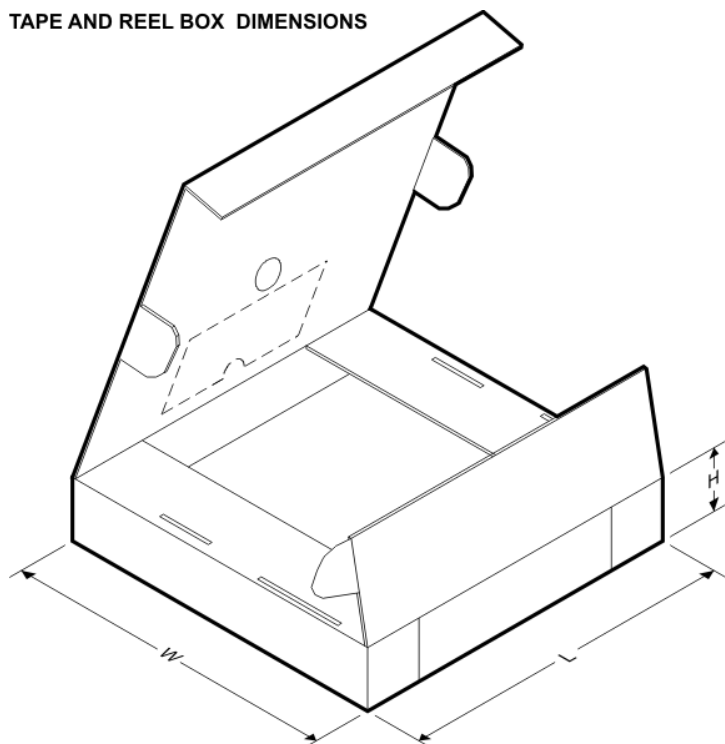


\*All dimensions are nominal

Device	Package Type	Package Drawing	Pins	SPQ	Reel Diameter (mm)	Reel Width W1 (mm)	A0 (mm)	B0 (mm)	K0 (mm)	P1 (mm)	W (mm)	Pin1 Quadrant
TLV62065TDSGRQ1	WSON	DSG	8	3000	179.0	8.4	2.2	2.2	1.2	4.0	8.0	Q2



**TAPE AND REEL BOX DIMENSIONS**



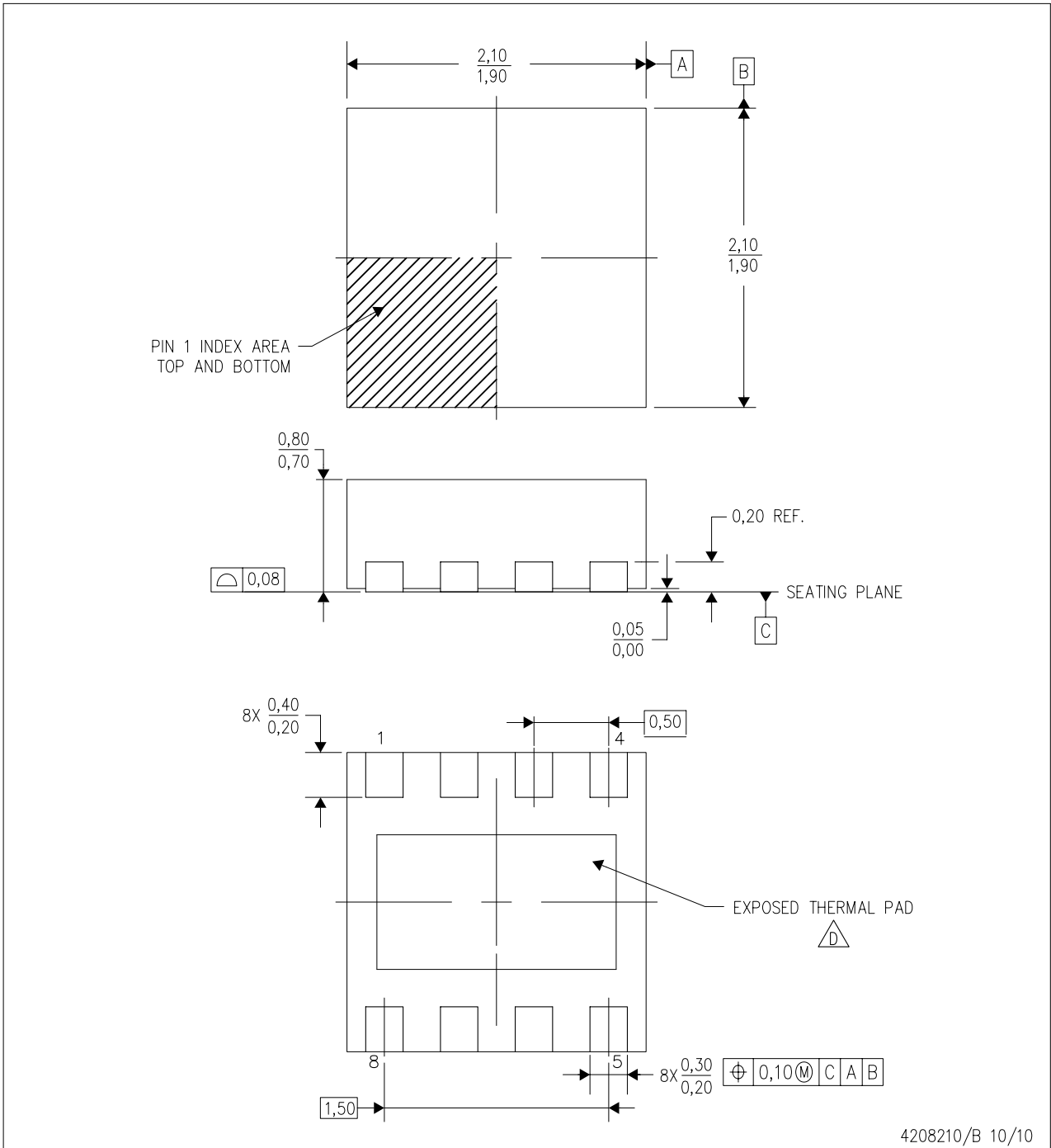
\*All dimensions are nominal


Device	Package Type	Package Drawing	Pins	SPQ	Length (mm)	Width (mm)	Height (mm)
TLV62065TDSGRQ1	WSON	DSG	8	3000	195.0	200.0	45.0

**MECHANICAL DATA**

DSG (S-PWSON-N8)

PLASTIC SMALL OUTLINE NO-LEAD



- NOTES:
- A. All linear dimensions are in millimeters. Dimensioning and tolerancing per ASME Y14.5M-1994.
  - B. This drawing is subject to change without notice.
  - C. Quad Flatpack, No-Leads (QFN) package configuration.
  -  The package thermal pad must be soldered to the board for thermal and mechanical performance. See the Product Data Sheet for details regarding the exposed thermal pad dimensions.
  - E. Falls within JEDEC MO-229.

**THERMAL PAD MECHANICAL DATA**

DSG (S-PWSON-N8)

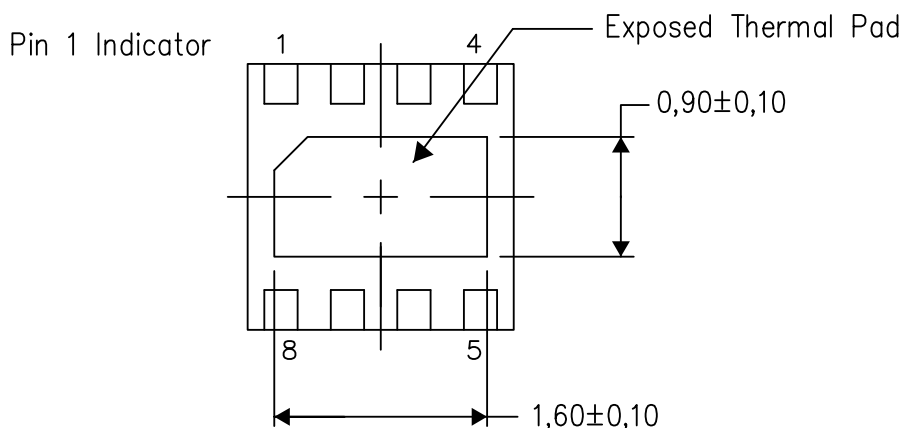
PLASTIC SMALL OUTLINE NO-LEAD

**THERMAL INFORMATION**

This package incorporates an exposed thermal pad that is designed to be attached directly to an external heatsink. The thermal pad must be soldered directly to the printed circuit board (PCB). After soldering, the PCB can be used as a heatsink. In addition, through the use of thermal vias, the thermal pad can be attached directly to the appropriate copper plane shown in the electrical schematic for the device, or alternatively, can be attached to a special heatsink structure designed into the PCB. This design optimizes the heat transfer from the integrated circuit (IC).

For information on the Quad Flatpack No-Lead (QFN) package and its advantages, refer to Application Report, QFN/SON PCB Attachment, Texas Instruments Literature No. SLUA271. This document is available at www.ti.com.

The exposed thermal pad dimensions for this package are shown in the following illustration.



Bottom View

Exposed Thermal Pad Dimensions

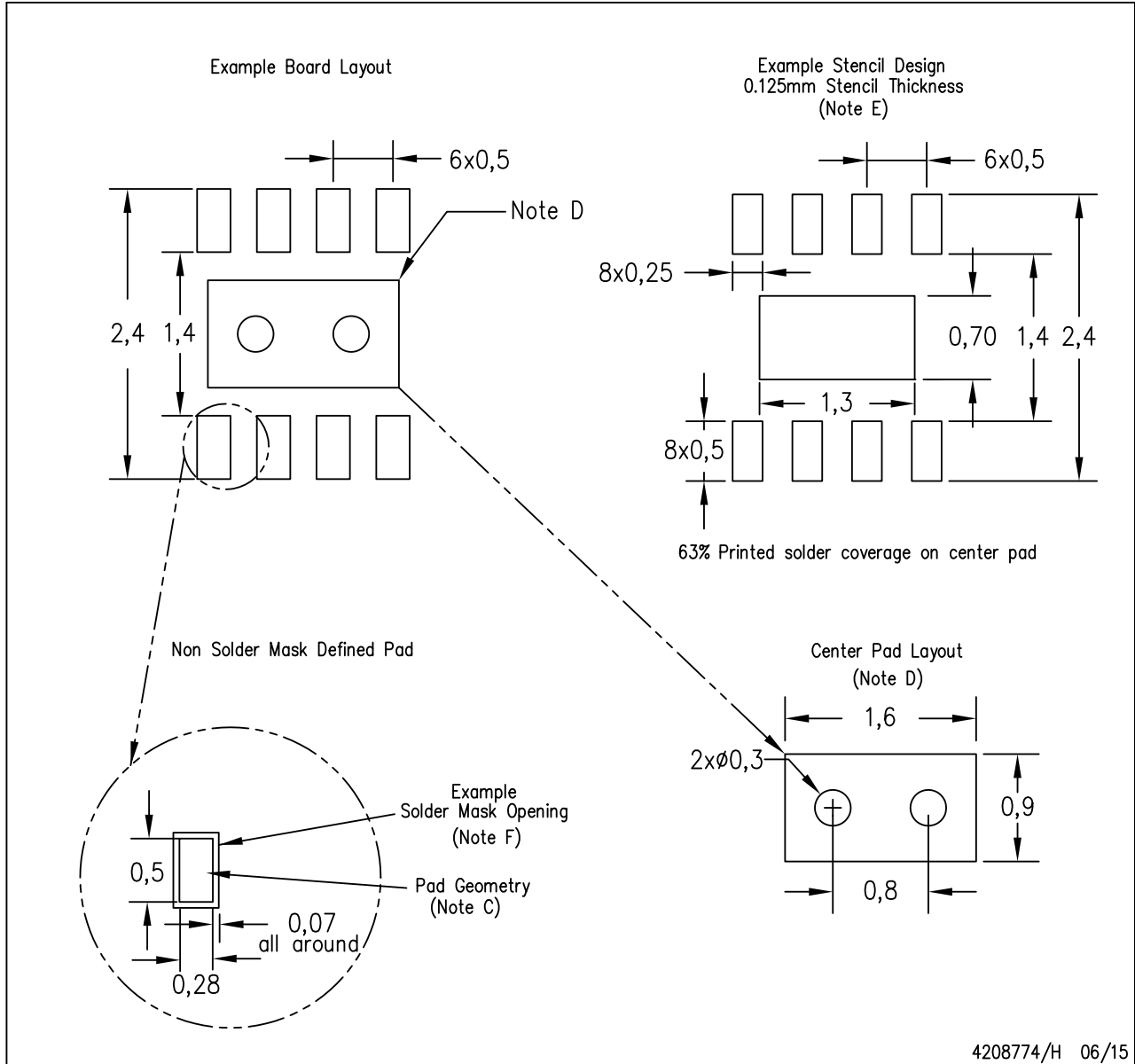
4208347/1 06/15

NOTE: All linear dimensions are in millimeters

**LAND PATTERN DATA**

DSG (S-PWSON-N8)

PLASTIC SMALL OUTLINE NO-LEAD



- NOTES:
- All linear dimensions are in millimeters.
  - This drawing is subject to change without notice.
  - Publication IPC-7351 is recommended for alternate designs.
  - This package is designed to be soldered to a thermal pad on the board. Refer to Application Note, QFN/SON PCB Attachment, Texas Instruments Literature No. SLUA271, and also the Product Data Sheets for specific thermal information, via requirements, and recommended board layout. These documents are available at [www.ti.com](http://www.ti.com) <<http://www.ti.com>>.
  - Laser cutting apertures with trapezoidal walls and also rounding corners will offer better paste release. Customers should contact their board assembly site for stencil design recommendations. Refer to IPC 7525 for stencil design considerations.
  - Customers should contact their board fabrication site for solder mask tolerances.

## IMPORTANT NOTICE

Texas Instruments Incorporated and its subsidiaries (TI) reserve the right to make corrections, enhancements, improvements and other changes to its semiconductor products and services per JESD46, latest issue, and to discontinue any product or service per JESD48, latest issue. Buyers should obtain the latest relevant information before placing orders and should verify that such information is current and complete. All semiconductor products (also referred to herein as “components”) are sold subject to TI’s terms and conditions of sale supplied at the time of order acknowledgment.

TI warrants performance of its components to the specifications applicable at the time of sale, in accordance with the warranty in TI’s terms and conditions of sale of semiconductor products. Testing and other quality control techniques are used to the extent TI deems necessary to support this warranty. Except where mandated by applicable law, testing of all parameters of each component is not necessarily performed.

TI assumes no liability for applications assistance or the design of Buyers’ products. Buyers are responsible for their products and applications using TI components. To minimize the risks associated with Buyers’ products and applications, Buyers should provide adequate design and operating safeguards.

TI does not warrant or represent that any license, either express or implied, is granted under any patent right, copyright, mask work right, or other intellectual property right relating to any combination, machine, or process in which TI components or services are used. Information published by TI regarding third-party products or services does not constitute a license to use such products or services or a warranty or endorsement thereof. Use of such information may require a license from a third party under the patents or other intellectual property of the third party, or a license from TI under the patents or other intellectual property of TI.

Reproduction of significant portions of TI information in TI data books or data sheets is permissible only if reproduction is without alteration and is accompanied by all associated warranties, conditions, limitations, and notices. TI is not responsible or liable for such altered documentation. Information of third parties may be subject to additional restrictions.

Resale of TI components or services with statements different from or beyond the parameters stated by TI for that component or service voids all express and any implied warranties for the associated TI component or service and is an unfair and deceptive business practice. TI is not responsible or liable for any such statements.

Buyer acknowledges and agrees that it is solely responsible for compliance with all legal, regulatory and safety-related requirements concerning its products, and any use of TI components in its applications, notwithstanding any applications-related information or support that may be provided by TI. Buyer represents and agrees that it has all the necessary expertise to create and implement safeguards which anticipate dangerous consequences of failures, monitor failures and their consequences, lessen the likelihood of failures that might cause harm and take appropriate remedial actions. Buyer will fully indemnify TI and its representatives against any damages arising out of the use of any TI components in safety-critical applications.

In some cases, TI components may be promoted specifically to facilitate safety-related applications. With such components, TI’s goal is to help enable customers to design and create their own end-product solutions that meet applicable functional safety standards and requirements. Nonetheless, such components are subject to these terms.

No TI components are authorized for use in FDA Class III (or similar life-critical medical equipment) unless authorized officers of the parties have executed a special agreement specifically governing such use.

Only those TI components which TI has specifically designated as military grade or “enhanced plastic” are designed and intended for use in military/aerospace applications or environments. Buyer acknowledges and agrees that any military or aerospace use of TI components which have **not** been so designated is solely at the Buyer’s risk, and that Buyer is solely responsible for compliance with all legal and regulatory requirements in connection with such use.

TI has specifically designated certain components as meeting ISO/TS16949 requirements, mainly for automotive use. In any case of use of non-designated products, TI will not be responsible for any failure to meet ISO/TS16949.

### Products

Audio	<a href="http://www.ti.com/audio">www.ti.com/audio</a>
Amplifiers	<a href="http://amplifier.ti.com">amplifier.ti.com</a>
Data Converters	<a href="http://dataconverter.ti.com">dataconverter.ti.com</a>
DLP® Products	<a href="http://www.dlp.com">www.dlp.com</a>
DSP	<a href="http://dsp.ti.com">dsp.ti.com</a>
Clocks and Timers	<a href="http://www.ti.com/clocks">www.ti.com/clocks</a>
Interface	<a href="http://interface.ti.com">interface.ti.com</a>
Logic	<a href="http://logic.ti.com">logic.ti.com</a>
Power Mgmt	<a href="http://power.ti.com">power.ti.com</a>
Microcontrollers	<a href="http://microcontroller.ti.com">microcontroller.ti.com</a>
RFID	<a href="http://www.ti-rfid.com">www.ti-rfid.com</a>
OMAP Applications Processors	<a href="http://www.ti.com/omap">www.ti.com/omap</a>
Wireless Connectivity	<a href="http://www.ti.com/wirelessconnectivity">www.ti.com/wirelessconnectivity</a>

### Applications

Automotive and Transportation	<a href="http://www.ti.com/automotive">www.ti.com/automotive</a>
Communications and Telecom	<a href="http://www.ti.com/communications">www.ti.com/communications</a>
Computers and Peripherals	<a href="http://www.ti.com/computers">www.ti.com/computers</a>
Consumer Electronics	<a href="http://www.ti.com/consumer-apps">www.ti.com/consumer-apps</a>
Energy and Lighting	<a href="http://www.ti.com/energy">www.ti.com/energy</a>
Industrial	<a href="http://www.ti.com/industrial">www.ti.com/industrial</a>
Medical	<a href="http://www.ti.com/medical">www.ti.com/medical</a>
Security	<a href="http://www.ti.com/security">www.ti.com/security</a>
Space, Avionics and Defense	<a href="http://www.ti.com/space-avionics-defense">www.ti.com/space-avionics-defense</a>
Video and Imaging	<a href="http://www.ti.com/video">www.ti.com/video</a>

### TI E2E Community

[e2e.ti.com](http://e2e.ti.com)