

Excellent Integrated System Limited

Stocking Distributor

Click to view price, real time Inventory, Delivery & Lifecycle Information:

[Bivar, Inc.](#)
[CP-00 BK](#)



For any questions, you can email us directly:
sales@integrated-circuit.com

REV.	DESCRIPTION	DATE	APPROVED
B	Engineering Update w/o Changes	02/24/04	M. C.
C	Added Note 4 & Color Options Sheet #2	05/16/16	J. C.

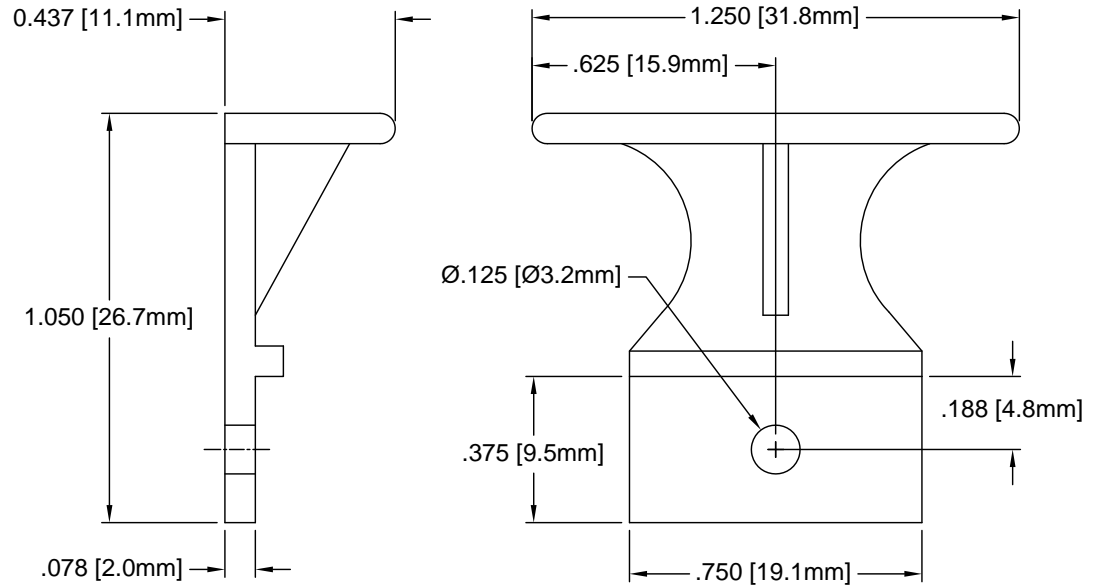
PART NO.	COLOR
CP-00 NT	NATURAL
CP-00 WE	WHITE
CP-00 XX	SEE S.#2



- 3. MATERIAL: NYLON 6/6, 94V-2, NATURAL.
- 2. MATERIAL: NYLON 6/6, 94V-2, WHITE.
- 1. GENERAL SPECIFICATIONS: BIVAR MOLDED COMPONENT SPECIFICATION BV00-E101.

STANDARD TOLERANCE (UNLESS OTHERWISE SPECIFIED)		 4 THOMAS, IRVINE, CA. 92618 TEL: (949) 951-8808 FAX: (949) 951-3974		
DECIMALS	ANGULAR			
.X ±.1	X° ± 1°	TITLE: CIRCUIT BOARD CARD EJECTOR		
.XX ±.01				
.XXX ±.005			PART NO: CP-00	REVISION: C
DESIGNED: S. Irving	DATE: 02/23/99	CAGE CODE : 32559 SHEET # 1 OF 2		
CHECKED: D. Green	DATE: 02/24/04	<small>CAD GENERATED DOCUMENT, DO NOT MEASURE DRAWING.</small>		



OTHER AVAILABLE COLORS

* SEE TABLE FOR ORDERING INFORMATION



REV.	DESCRIPTION	DATE	APPROVED
	SEE SHEET #1		

CP-00 --

CP SERIES

ORDER CODE	COLOR
AA	AQUA
BK	BLACK
BE	BLUE
BN	BROWN
FG	FOREST GREEN
GY	GRAY
GN	GREEN
LE	LIME
OE	ORANGE
PK	PINK
RD	RED
VT	VIOLET
YW	YELLOW

4. PARTS ARE DYED TO COLOR UPON REQUEST.

STANDARD TOLERANCE (UNLESS OTHERWISE SPECIFIED) DECIMALS ANGULAR		 4 THOMAS, IRVINE, CA. 92618 TEL: (949) 951-8808 FAX: (949) 951-3974	
		 TITLE: CIRCUIT BOARD CARD EJECTOR	
DESIGNED: S. Irving	DATE: 02/23/99	PART NO: CP-00	REVISION: C
CHECKED: D. Green	DATE: 02/24/04	CAGE CODE : 32559	SHEET # 2 OF 2
CAD GENERATED DOCUMENT. DO NOT MEASURE DRAWING.			