



Excellent Integrated System Limited

Stocking Distributor

Click to view price, real time Inventory, Delivery & Lifecycle Information:

[Bivar, Inc.](#)
[N-250-2-CI](#)

For any questions, you can email us directly:
sales@integrated-circuit.com



Distributor of Bivar, Inc.: Excellent Integrated System Limited

Datasheet of N-250-2-CI - CARD GUIDE NAR 2.5X0.078" NAT

Contact us: sales@integrated-circuit.com Website: www.integrated-circuit.com

ITEM	QTY	PART NUMBER	PART DESCRIPTION
1	1	N-XXX-X	NARROW PRESS-IN CARD GUIDE
2	1	CS-600-F XX.XX	CONDUCTIVE INSERT

REV.	DESCRIPTION	DATE	APPROVED
B	Eco#388, Engineering Update.	05/01/03	M. C.
C	CI Length (.15" max) Update.	10/06/09	T. Y.
D	Engineering Update w/o Changes.	05/17/16	J. C.

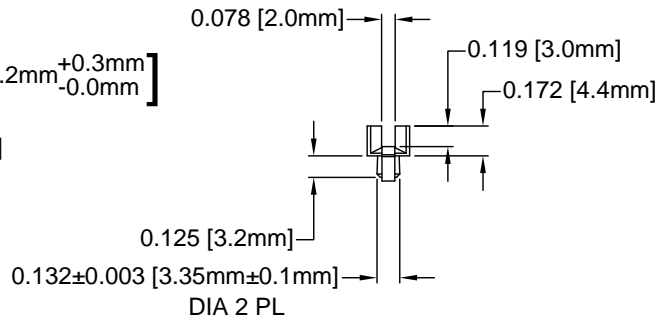
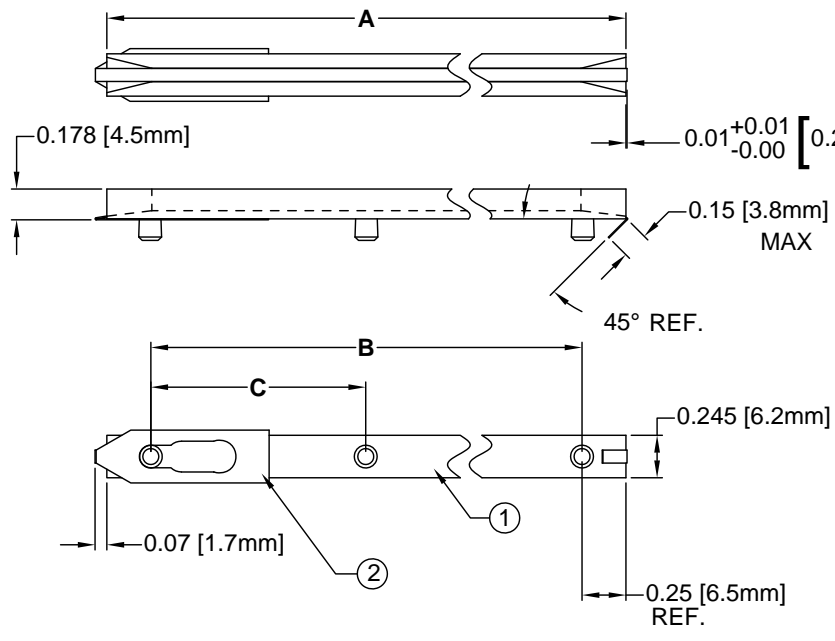

PART NO.	CONDUCTIVE INSERT	A ± 0.030 (.76)	B ± 0.024 (.61)	C ± 0.016 (.41)
N-250-2-CI	CS-600-F 10.75	2.5 (63.5)	2.0 (50.8)	--
N-300-2-CI	CS-600-F 10.75	3.0 (76.2)	2.5 (63.5)	--
N-350-2-CI	CS-600-F 10.75	3.5 (88.9)	3.0 (76.2)	--
N-400-2-CI	CS-600-F 10.75	4.0 (101.6)	3.5 (88.9)	--
N-450-2-CI	CS-600-F 10.75	4.5 (114.3)	4.0 (101.6)	--
N-500-2-CI	CS-600-F 10.75	5.0 (127.0)	4.5 (114.3)	--
N-550-2-CI	CS-600-F 10.75	5.5 (139.7)	5.0 (127.0)	--
N-600-2-CI	CS-600-F 10.75	6.0 (152.4)	5.5 (139.7)	--
N-650-2-CI	CS-600-F 10.75	6.5 (165.1)	6.0 (152.4)	--
N-700-2-CI	CS-600-F 10.75	7.0 (177.8)	6.5 (165.1)	--
N-700-3-CI	CS-600-F 10.75	7.0 (177.8)	6.5 (165.1)	3.25 (82.5)
N-750-2-CI	CS-600-F 10.75	7.5 (190.5)	7.0 (177.8)	--
N-750-3-CI	CS-600-F 10.75	7.5 (190.5)	7.0 (177.8)	3.50 (88.9)
N-800-2-CI	CS-600-F 10.75	8.0 (203.2)	7.5 (190.5)	--
N-800-3-CI	CS-600-F 10.75	8.0 (203.2)	7.5 (190.5)	3.75 (95.2)
N-850-2-CI	CS-600-F 14.00	8.5 (215.9)	8.0 (203.2)	--
N-850-3-CI	CS-600-F 14.00	8.5 (215.9)	8.0 (203.2)	4.00 (101.6)

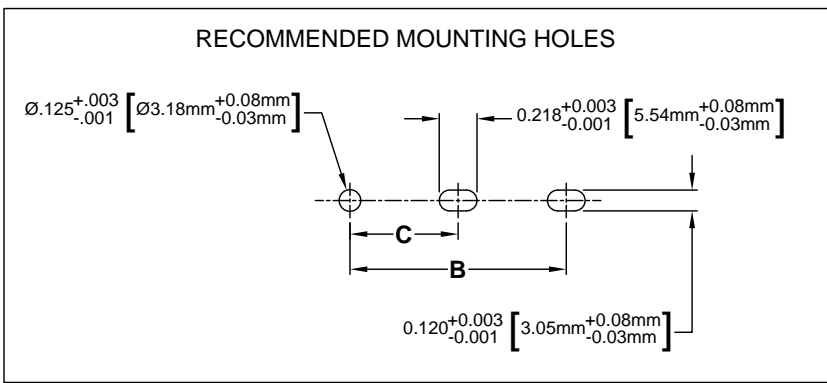

STANDARD TOLERANCE (UNLESS OTHERWISE SPECIFIED)		 BIVAR [®] 4 THOMAS, IRVINE, CA. 92618 TEL: (949) 951-8808 FAX: (949) 951-3974
DECIMALS	ANGULAR	
.X $\pm .1$	X° $\pm 1^\circ$	TITLE: NARROW PRESS-IN CARD GUIDE W/ CONDUCTIVE INSERT PART NO: N-XXX-X-CI REVISION: D
.XX $\pm .01$		
.XXX $\pm .005$		
DESIGNED: M. Chen	DATE: 02/06/03	CAGE CODE : 32559 SHEET # 1 OF 1 CAD GENERATED DOCUMENT. DO NOT MEASURE DRAWING.
CHECKED: D. Green	DATE: 02/06/03	