

## Excellent Integrated System Limited

Stocking Distributor

Click to view price, real time Inventory, Delivery & Lifecycle Information:

[Molex Connector Corporation](#)  
[0015477542](#)

For any questions, you can email us directly:

[sales@integrated-circuit.com](mailto:sales@integrated-circuit.com)

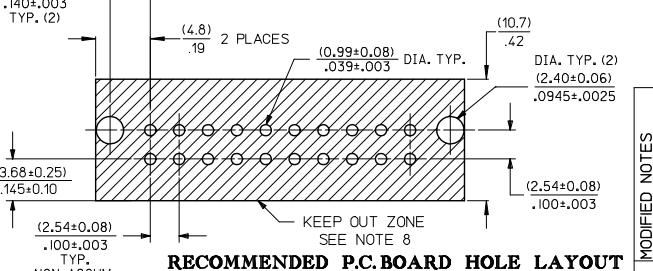
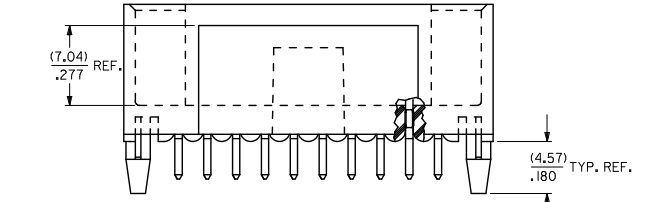
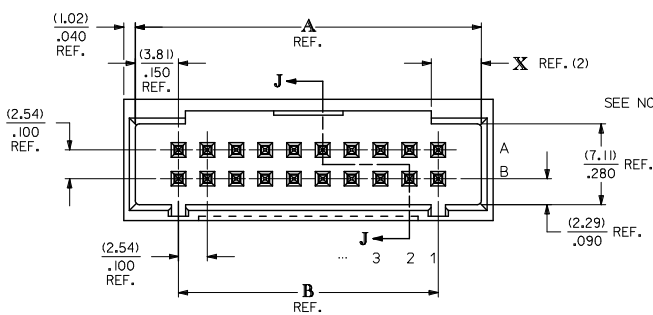
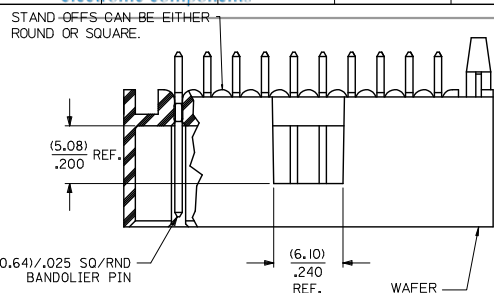

- NOTES:
1. MATERIAL: WAFER - GLASS FILLED LIQUID CRYSTAL POLYMER, UL 94V-0, COLOR: BLACK, PIN: COPPER ALLOY, TIN(SN) ALLOY OVER ENTIRE PIN. THICKNESS = (3.81 MICROMETER)/ 150 MICRONCH MINIMUM, NICKEL (Ni) UNDERPLATE OVER ENTIRE PIN.
  2. PLATING: 15 GOLD SELECTIVE GOLD (Au) IN THE CONTACT AREA: THICKNESS = (0.38 MICROMETER)/ 15 MICRONCH MINIMUM, SELECTIVE TIN (Sn) ALLOY IN THE PC TAIL AREA: THICKNESS = (1.91 MICROMETER)/ 75 MICRONCH MINIMUM, NICKEL (Ni) UNDERPLATE OVER ENTIRE PIN. 30 GOLD SELECTIVE GOLD (Au) IN THE CONTACT AREA: THICKNESS = (0.76 MICROMETER)/ 30 MICRONCH MINIMUM, SELECTIVE TIN (Sn) ALLOY IN THE PC TAIL AREA: THICKNESS = (1.91 MICROMETER)/ 75 MICRONCH MINIMUM, NICKEL (Ni) UNDERPLATE OVER ENTIRE PIN. \* THE PRIMARY SHIPPING CARTON WILL BE LABELED "COMPLIANT TO R0HS DIRECTIVE 2002/95/EC AND ELV ANNEX II OF DIRECTIVE 2000/53/EC. CARTONS WITHOUT THIS LABEL MAY CONTAIN PRODUCT WITH LEAD.
  3. PRODUCT SPECIFICATION: PS-70567.
  4. PACKAGING: SEE CHARTS.
  5. PIN PUSHOUT FORCE: 4 LS. MIN. IN DIRECTION INDICATED.
  6. FOR ILLUSTRATION PURPOSES, 20 (DUAL 10) CIRCUIT SIZE IS SHOWN.
  7. PINS MUST MEET SOLDERABILITY SPEC. SMES-152.
  8. EXCEPT Voids ARE PERMISSIBLE AT BANDOLIER PIN FAYING SURFACE. (APPROX. (0.64)/.025 LNX X (0.15)/.006 WD. REF.) - 2 LOCATIONS
  9. NO FEATURES WHICH RISE ABOVE THE PCB SURFACE ALLOWED IN THIS AREA.
  10. THIS PART CONFORMS TO CLASS B REQUIREMENTS OF COSMETIC SPEC PS-45499-002.

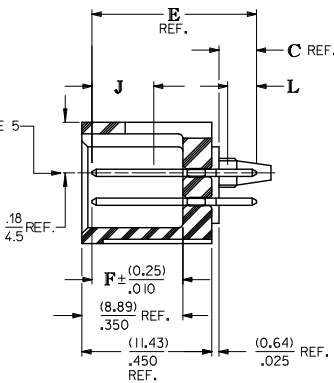

CKT. SIZE	DIM. A REF.		DIM. B REF.		DIM. X REF.	
	(MM)	INCH	(MM)	INCH	(MM)	INCH
6	(12.70)	.500	(5.08)	.200	(3.18)	.125
8	(15.24)	.600	(7.62)	.300	(4.42)	.174
10	(17.78)	.700	(10.16)	.400	(4.42)	.174
12	(20.32)	.800	(12.70)	.500	(4.42)	.174
14	(22.86)	.900	(15.24)	.600	(4.42)	.174
16	(25.40)	1.000	(17.78)	.700	(4.42)	.174
18	(27.94)	1.100	(20.32)	.800	(4.42)	.174
20	(30.48)	1.200	(22.86)	.900	(4.42)	.174
22	(33.02)	1.300	(25.40)	1.000	(4.42)	.174
24	(35.56)	1.400	(27.94)	1.100	(4.42)	.174
26	(38.10)	1.500	(30.48)	1.200	(4.42)	.174
28	(40.64)	1.600	(33.02)	1.300	(4.42)	.174
30	(43.18)	1.700	(35.56)	1.400	(4.42)	.174
32	(45.72)	1.800	(38.10)	1.500	(4.42)	.174
34	(48.26)	1.900	(40.64)	1.600	(4.42)	.174
36	(50.80)	2.000	(43.18)	1.700	(4.42)	.174
38	(53.34)	2.100	(45.72)	1.800	(4.42)	.174
40	(55.88)	2.200	(48.26)	1.900	(4.42)	.174
42	(58.42)	2.300	(50.80)	2.000	(4.42)	.174
44	(60.96)	2.400	(53.34)	2.100	(4.42)	.174
46	(63.50)	2.500	(55.88)	2.200	(4.42)	.174
48	(66.04)	2.600	(58.42)	2.300	(4.42)	.174
50	(68.58)	2.700	(60.96)	2.400	(4.42)	.174
52	(71.12)	2.800	(63.50)	2.500	(4.42)	.174
54	(73.66)	2.900	(66.04)	2.600	(4.42)	.174
56	(76.20)	3.000	(68.58)	2.700	(4.42)	.174
58	(78.74)	3.100	(71.12)	2.800	(4.42)	.174
60	(81.28)	3.200	(73.66)	2.900	(4.42)	.174
62	(83.82)	3.300	(76.20)	3.000	(4.42)	.174
64	(86.36)	3.400	(78.74)	3.100	(4.42)	.174
66	(88.90)	3.500	(81.28)	3.200	(4.42)	.174
68	(91.44)	3.600	(83.82)	3.300	(4.42)	.174
70	(93.98)	3.700	(86.36)	3.400	(4.42)	.174
72	(96.52)	3.800	(88.90)	3.500	(4.42)	.174

**MODIFIED NOTES:**  
 EC NO: UCP/2009-0336  
 DRAWN: J. CLUSTE (E) 2008/09/23  
 CHKD: BELL 2008/09/24  
 APPROV: SMITH 2008/09/25

**QUALITY SYMBOLS:**  
 ▽=0  
 ▽=0

**GENERAL TOLERANCES (UNLESS SPECIFIED):**

	mm	INCH
4 PLACES ±	---	---
3 PLACES ±	---	±.005
2 PLACES ±	0.13	±.01
1 PLACE ±	0.25	±---

ANGULAR ±1/2°

**DRAFT WHERE APPLICABLE MUST REMAIN WITHIN DIMENSIONS**

**GENERAL TOLERANCES (UNLESS SPECIFIED):** MM/IN

DRAWN BY	DATE	TITLE
SMR	1993/11/10	SALES ASSY - DUAL ROW SHROUDED WAFER/HI TEMP .25SQ/RND PINS .100 GRID
CHECKED BY	DATE	
SMR	1993/11/10	
APPROVED BY	DATE	

**MATERIAL NO.:** SEE TABLE  
**DOCUMENT NO.:** SDA-70568-\*\*\*\*  
**SHEET NO.:** 1 OF 2

**SALES ASSY - DUAL ROW SHROUDED WAFER/HI TEMP .25SQ/RND PINS .100 GRID**

**MOLEX INCORPORATED**

**THIS DRAWING CONTAINS INFORMATION THAT IS PROPRIETARY TO MOLEX INCORPORATED AND SHOULD NOT BE USED WITHOUT WRITTEN PERMISSION**



**Distributor of Molex Connector Corporation: Excellent Integrated System Limited**  
 Datasheet of 0015477542 - CONN HEADER 42POS VERT TIN T/H  
 Contact us: sales@integrated-circuit.com Website: www.integrated-circuit.com

J	ENGINEERING NUMBER A-70568	RELEASE FOR MANUFACTURE	C REF.	E REF.	F ±(0.25) / .10	CONNECTOR END PLATING		P.C. BOARD END PLATING		SEE PACK INFORMAT. DRAWING PK-70873
						TYPE	J MINIMUM LENGTH	TYPE	L MINIMUM LENGTH	
	-0001/0034	R.F.M.	(3,30) .130	(14,48) .570	(8,00) .315	TIN	OVER-ALL	TIN	OVER-ALL	-0018
	-0035/-0068	R.F.M.	(3,30) .130	(14,48) .570	(8,00) .315	15 GOLD	(5,08) .200	TIN	(3,56) .140	-0018
I	-0069/-0102	R.F.M.	(3,30) .130	(14,48) .570	(8,00) .315	30 GOLD	(5,08) .200	TIN	(3,56) .140	-0018
	-0103/-0136									
	-0137/-0170									
H	-0171/-0204									
	-0205/-0238									

G	CKTS	EDP NUMBER	ENG NUMBER	EDP NUMBER	ENG NUMBER	EDP NUMBER	ENG NUMBER	EDP NUMBER	ENG NUMBER	EDP NUMBER	ENG NUMBER	EDP NUMBER	ENG NUMBER	EDP NUMBER	ENG NUMBER	CKTS
	06	I5-47-7506	A-70568-0001	I5-47-7606	A-70568-0035	I5-47-7706	A-70568-0069		A-70568-0103		A-70568-0137		A-70568-0171		A-70568-0205	06
	08	I5-47-7508	A-70568-0002	I5-47-7608	A-70568-0036	I5-47-7708	A-70568-0070		A-70568-0104		A-70568-0138		A-70568-0172		A-70568-0206	08
	10	I5-47-7510	A-70568-0003	I5-47-7610	A-70568-0037	I5-47-7710	A-70568-0071		A-70568-0105		A-70568-0139		A-70568-0173		A-70568-0207	10
	12	I5-47-7512	A-70568-0004	I5-47-7612	A-70568-0038	I5-47-7712	A-70568-0072		A-70568-0106		A-70568-0140		A-70568-0174		A-70568-0208	12
	14	I5-47-7514	A-70568-0005	I5-47-7614	A-70568-0039	I5-47-7714	A-70568-0073		A-70568-0107		A-70568-0141		A-70568-0175		A-70568-0209	14
	16	I5-47-7516	A-70568-0006	I5-47-7616	A-70568-0040	I5-47-7716	A-70568-0074		A-70568-0108		A-70568-0142		A-70568-0176		A-70568-0210	16
	18	I5-47-7518	A-70568-0007	I5-47-7618	A-70568-0041	I5-47-7718	A-70568-0075		A-70568-0109		A-70568-0143		A-70568-0177		A-70568-0211	18
	20	I5-47-7520	A-70568-0008	I5-47-7620	A-70568-0042	I5-47-7720	A-70568-0076		A-70568-0110		A-70568-0144		A-70568-0178		A-70568-0212	20
	22	I5-47-7522	A-70568-0009	I5-47-7622	A-70568-0043	I5-47-7722	A-70568-0077		A-70568-0111		A-70568-0145		A-70568-0179		A-70568-0213	22
F	24	I5-47-7524	A-70568-0010	I5-47-7624	A-70568-0044	I5-47-7724	A-70568-0078		A-70568-0112		A-70568-0146		A-70568-0180		A-70568-0214	24
	26	I5-47-7526	A-70568-0011	I5-47-7626	A-70568-0045	I5-47-7726	A-70568-0079		A-70568-0113		A-70568-0147		A-70568-0181		A-70568-0215	26
	28	I5-47-7528	A-70568-0012	I5-47-7628	A-70568-0046	I5-47-7728	A-70568-0080		A-70568-0114		A-70568-0148		A-70568-0182		A-70568-0216	28
	30	I5-47-7530	A-70568-0013	I5-47-7630	A-70568-0047	I5-47-7730	A-70568-0081		A-70568-0115		A-70568-0149		A-70568-0183		A-70568-0217	30
	32	I5-47-7532	A-70568-0014	I5-47-7632	A-70568-0048	I5-47-7732	A-70568-0082		A-70568-0116		A-70568-0150		A-70568-0184		A-70568-0218	32
	34	I5-47-7534	A-70568-0015	I5-47-7634	A-70568-0049	I5-47-7734	A-70568-0083		A-70568-0117		A-70568-0151		A-70568-0185		A-70568-0219	34
	36	I5-47-7536	A-70568-0016	I5-47-7636	A-70568-0050	I5-47-7736	A-70568-0084		A-70568-0118		A-70568-0152		A-70568-0186		A-70568-0220	36
E	38	I5-47-7538	A-70568-0017	I5-47-7638	A-70568-0051	I5-47-7738	A-70568-0085		A-70568-0119		A-70568-0153		A-70568-0187		A-70568-0221	38
	40	I5-47-7540	A-70568-0018	I5-47-7640	A-70568-0052	I5-47-7740	A-70568-0086		A-70568-0120		A-70568-0154		A-70568-0188		A-70568-0222	40
	42	I5-47-7542	A-70568-0019	I5-47-7642	A-70568-0053	I5-47-7742	A-70568-0087		A-70568-0121		A-70568-0155		A-70568-0189		A-70568-0223	42
	44	I5-47-7544	A-70568-0020	I5-47-7644	A-70568-0054	I5-47-7744	A-70568-0088		A-70568-0122		A-70568-0156		A-70568-0190		A-70568-0224	44
	46	I5-47-7546	A-70568-0021	I5-47-7646	A-70568-0055	I5-47-7746	A-70568-0089		A-70568-0123		A-70568-0157		A-70568-0191		A-70568-0225	46
	48	I5-47-7548	A-70568-0022	I5-47-7648	A-70568-0056	I5-47-7748	A-70568-0090		A-70568-0124		A-70568-0158		A-70568-0192		A-70568-0226	48
	50	I5-47-7550	A-70568-0023	I5-47-7650	A-70568-0057	I5-47-7750	A-70568-0091		A-70568-0125		A-70568-0159		A-70568-0193		A-70568-0227	50
D	52	I5-47-7552	A-70568-0024	I5-47-7652	A-70568-0058	I5-47-7752	A-70568-0092		A-70568-0126		A-70568-0160		A-70568-0194		A-70568-0228	52
	54	I5-47-7554	A-70568-0025	I5-47-7654	A-70568-0059	I5-47-7754	A-70568-0093		A-70568-0127		A-70568-0161		A-70568-0195		A-70568-0229	54
	56	I5-47-7556	A-70568-0026	I5-47-7656	A-70568-0060	I5-47-7756	A-70568-0094		A-70568-0128		A-70568-0162		A-70568-0196		A-70568-0230	56
	58	I5-47-7558	A-70568-0027	I5-47-7658	A-70568-0061	I5-47-7758	A-70568-0095		A-70568-0129		A-70568-0163		A-70568-0197		A-70568-0231	58
	60	I5-47-7560	A-70568-0028	I5-47-7660	A-70568-0062	I5-47-7760	A-70568-0096		A-70568-0130		A-70568-0164		A-70568-0198		A-70568-0232	60
	62	I5-47-7562	A-70568-0029	I5-47-7662	A-70568-0063	I5-47-7762	A-70568-0097		A-70568-0131		A-70568-0165		A-70568-0199		A-70568-0233	62
	64	I5-47-7564	A-70568-0030	I5-47-7664	A-70568-0064	I5-47-7764	A-70568-0098		A-70568-0132		A-70568-0166		A-70568-0200		A-70568-0234	64
	66	I5-47-7566	A-70568-0031	I5-47-7666	A-70568-0065	I5-47-7766	A-70568-0099		A-70568-0133		A-70568-0167		A-70568-0201		A-70568-0235	66
	68	I5-47-7568	A-70568-0032	I5-47-7668	A-70568-0066	I5-47-7768	A-70568-0100		A-70568-0134		A-70568-0168		A-70568-0202		A-70568-0236	68
C	70	I5-47-7570	A-70568-0033	I5-47-7670	A-70568-0067	I5-47-7770	A-70568-0101		A-70568-0135		A-70568-0169		A-70568-0203		A-70568-0237	70
	72	I5-47-7572	A-70568-0034	I5-47-7672	A-70568-0068	I5-47-7772	A-70568-0102		A-70568-0136		A-70568-0170		A-70568-0204		A-70568-0238	72

B	MODIFY PLATE EC NO: UCP2006-2806 CHIKKIDINGAN APPROX: MILLER 20/06/07	QUALITY SYMBOLS ▽=0 ▽=0	GENERAL TOLERANCES (UNLESS SPECIFIED)		DIMENSION STYLE		SCALE	DESIGN UNITS	THIRD ANGLE PROJECTION
			mm	INCH	MM/IN	---	INCH	DRAWN BY: SMR CHECKED BY: SMR APPROVED BY: SMR DATE: 1993/11/10	TITLE: SALES ASSY-DUAL ROW SHROUDED WAFER/HIGH TEMP .025SQ/RND PIN .100 GRID MOLEX INCORPORATED
A	DRAFT WHERE APPLICABLE MUST REMAIN WITHIN DIMENSIONS		MATERIAL NO. SEE TABLE		DOCUMENT NO. SDA-70568-****		SHEET NO. 2 OF 2		