

Excellent Integrated System Limited

Stocking Distributor

Click to view price, real time Inventory, Delivery & Lifecycle Information:

[Molex Connector Corporation](#)
[0026607110](#)

For any questions, you can email us directly:

sales@integrated-circuit.com

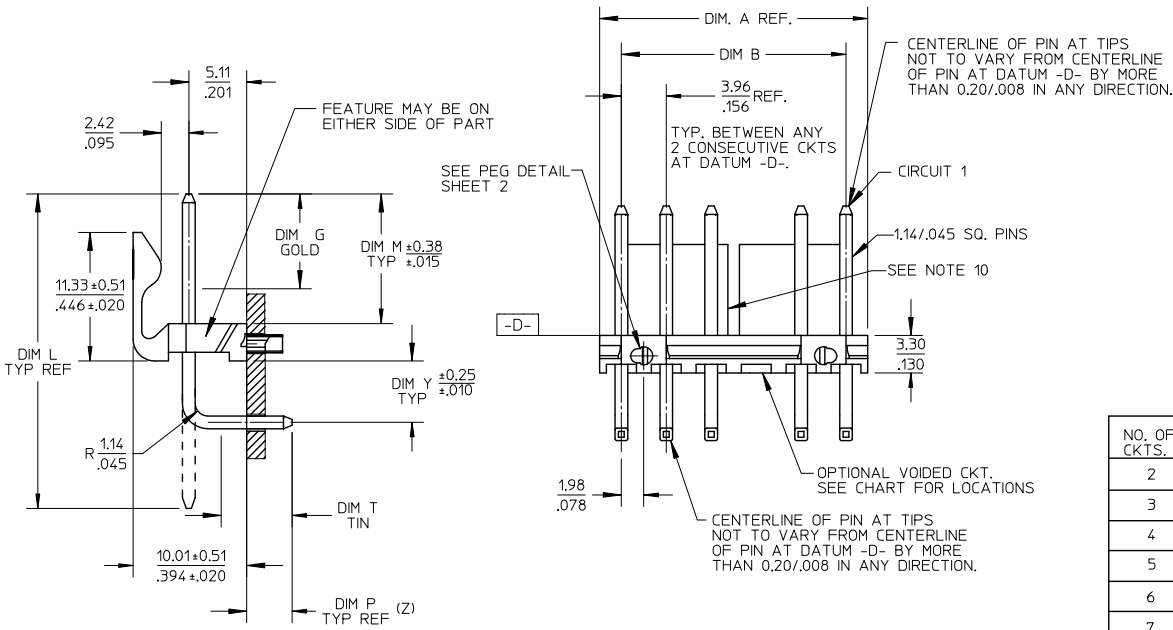

NO. OF CKTS.	DIM. A	DIM. B	SLOT LOC BETWEEN CKTS
2	7.77 .306	3.96±0.05 .156±.002	NONE
3	11.73 .462	7.92±0.08 .312±.003	NONE
4	15.70 .618	11.89±0.08 .468±.003	NONE
5	19.66 .774	15.85±0.10 .624±.004	NONE
6	23.62 .930	19.81±0.10 .780±.004	3 & 4
7	27.58 1.086	23.77±0.10 .936±.004	4 & 5
8	31.55 1.242	27.74±0.13 1.092±.005	4 & 5
9	35.51 1.398	31.70±0.13 1.248±.005	5 & 6
10	39.47 1.554	35.66±0.13 1.404±.005	5 & 6
11	43.43 1.710	39.62±0.15 1.560±.006	6 & 7
12	47.40 1.866	43.59±0.15 1.716±.006	4 & 5 8 & 9

QUALITY SYMBOLS 	GENERAL TOLERANCES (UNLESS SPECIFIED) <table border="1"> <thead> <tr> <th></th> <th>mm</th> <th>INCH</th> </tr> </thead> <tbody> <tr> <td>4 PLACES</td> <td>± ---</td> <td>± ---</td> </tr> <tr> <td>3 PLACES</td> <td>± ---</td> <td>± .010</td> </tr> <tr> <td>2 PLACES</td> <td>± 0.25</td> <td>± .015</td> </tr> <tr> <td>1 PLACE</td> <td>± 0.38</td> <td>± ---</td> </tr> <tr> <td>0 PLACE</td> <td>±</td> <td>±</td> </tr> </tbody> </table>		mm	INCH	4 PLACES	± ---	± ---	3 PLACES	± ---	± .010	2 PLACES	± 0.25	± .015	1 PLACE	± 0.38	± ---	0 PLACE	±	±	DIMENSION STYLE MM/IN SCALE 2:1 DESIGN UNITS INCH THIRD ANGLE PROJECTION	TITLE FRICITION LOCK HDR. ASSY. .156 BENT SQ PINS W/PEGS RT. ANGLE MOUNT molex
		mm	INCH																		
	4 PLACES	± ---	± ---																		
	3 PLACES	± ---	± .010																		
2 PLACES	± 0.25	± .015																			
1 PLACE	± 0.38	± ---																			
0 PLACE	±	±																			
DIMENSION M IEC NO: UCP2013-1786 DRWN:MMSTROH 2012/11/05 CHKD:KK IPPER 2012/11/07 APPR:FSM TH 2012/11/06 H2 REV	ANGULAR ±1/2° DRAFT WHERE APPLICABLE MUST REMAIN WITHIN DIMENSIONS	DRAWN BY SCHAFFER DATE 12-12-03 CHECKED BY SAMIEC DATE 12-15-03 APPROVED BY MARGULIS DATE 12-19-03 MATERIAL NO. SEE CHART	DOCUMENT NO. SD-42892-001 SHEET NO. 1 OF *																		
THIS DRAWING CONTAINS INFORMATION THAT IS PROPRIETARY TO MOLEX INCORPORATED AND SHOULD NOT BE USED WITHOUT WRITTEN PERMISSION																					

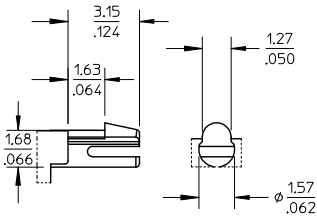

PEG DETAIL

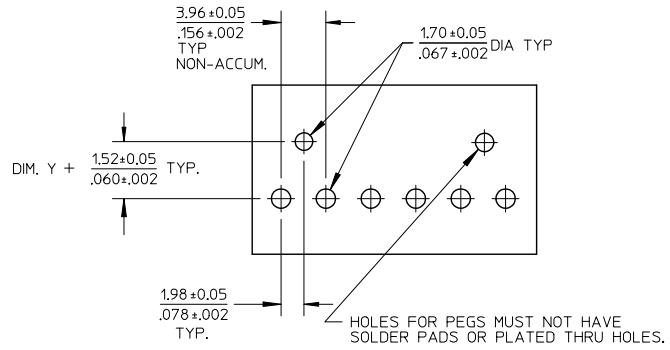

RECOMMENDED PC BOARD HOLE LAYOUT:
COMPONENT SIDE FOR 1.57/.062 THICK PCB

FOR CORRECT ORIENTATION OF PARTS WITH VOIDS, ELIMINATE CORRESPONDING PCB HOLE.

NOTES:

1. MATERIAL: HEADER-GLASS FILLED POLYESTER, 94V-0, MOLDED NATURAL WHITE
PINS: BRASS
2. FINISHES: (197) OVERALL REFLOWED MATTE TIN: 0.00152/.000060 MIN.
OVER 0.00127/.000050 MIN. NICKEL OVERALL.
(208) SELECT GOLD: 0.00038/.000015
SELECT TIN: 0.00254/.000100
OVERALL NICKEL UNDERPLATE: 0.00127/.000050
(228) SELECT GOLD: 0.00076/.000030
SELECT TIN: 0.00254/.000100
OVERALL NICKEL UNDERPLATE: 0.00127/.000050
(241) SELECT GOLD: 0.00051/.000020 MIN.
SELECT TIN: 0.00254/.000100 MIN.
OVERALL NICKEL UNDERPLATE: 0.00127/.000050 MIN.
3. PRODUCT SPECIFICATION: SEE PS-08-50.
4. PACKAGING INFO: SEE TABLES
5. SOLDERABILITY: PER SMES-152
6. PIN PUSH OUT FORCE: PRIOR TO SOLDERING, A 3 LB MINIMUM FORCE (IN EITHER DIRECTION) SHALL BE REQUIRED TO PUSH THE PIN OUT OF THE HEADER.
7. PARTS ARE STACKABLE END TO END ON (3.96)/.156 CENTERS.
8. FOR PART WITHOUT PEGS SEE DWG. NO. SDA-41792.
9. THIS PART CONFORMS TO CLASS B REQUIREMENTS OF COSMETIC SPECIFICATION PS-45499-002.
10. SLOTS ON BACKWALL ARE BETWEEN CIRCUITS. SEE CHART FOR LOCATION.

SEE SHEET 1 EC NO: UCP2013-1786 DRWN:MMSTROH 2012/11/05 CHKD:MKIPPER 2012/11/07 APPR:FSMLTH 2012/11/06 H2 REV	QUALITY SYMBOLS	GENERAL TOLERANCES (UNLESS SPECIFIED)		DIMENSION STYLE MM/IN		SCALE 2:1	DESIGN UNITS INCH	THIRD ANGLE PROJECTION
	▽=0	4 PLACES	± ---	± ---	DRAWN BY SCHAFFER	DATE 12-12-03	TITLE FRICTION LOCK HDR. ASSY. .156 BENT SQ PINS W/PEGS RT. ANGLE MOUNT molex DOCUMENT NO. SD-42892-001 SHEET NO. 2 OF *	
	▽=0	3 PLACES	± ---	± .010	CHECKED BY SAMIEC	DATE 12-15-03		
	▽=0	2 PLACES	± 0.25	± .015	APPROVED BY MARGULIS	DATE 12-19-03		
	▽=0	1 PLACE	± 0.38	± ---	MATERIAL NO. SEE CHART			
▽=0	0 PLACE	±	±	SIZE A				
		ANGULAR ±1/2°		DRAFT WHERE APPLICABLE MUST REMAIN WITHIN DIMENSIONS		THIS DRAWING CONTAINS INFORMATION THAT IS PROPRIETARY TO MOLEX INCORPORATED AND SHOULD NOT BE USED WITHOUT WRITTEN PERMISSION		