

Excellent Integrated System Limited

Stocking Distributor

Click to view price, real time Inventory, Delivery & Lifecycle Information:

[Molex Connector Corporation](#)
[0192210785](#)

For any questions, you can email us directly:

sales@integrated-circuit.com

UNPLATED MATERIAL NUMBER	UNPLATED ENG. NUMBER	UNPLATED MAT. NO. ON TAPE	UNPLATED ENG. NO. ON TAPE	PLATED MATERIAL NUMBER	PLATED ENGINEERING NUMBER	PLATED MAT. NO. ON TAPE	PLATED ENG. NO. ON TAPE	SEE DETAIL	STUD SIZE	WIRE RANGE	③ "S"	③ "L"	③ "W"	③ "C"	③ "B"	③ "T"
1922 10451	BCL-410	---	---	1922 10452	BCL-410-PL	---	---	---	10/4.8mm	4 AWG/25mm ²	.214/5.45	1.500/38.10	.531/13.49	.429/10.90	.286/7.26	.080/2.03
1922 10404	BCL-414	---	---	1922 10230	BCL-414-PL	---	---	---	1/4"/M6	4 AWG/25mm ²	.278/7.06	1.500/38.10	.531/13.49	.429/10.90	.286/7.26	.080/2.03
1922 10405	BCL-4516	---	---	1922 10231	BCL-4516-PL	190820025	BCL-4516-PLT	D ③	5/16"/M8	4 AWG/25mm ²	.340/8.64	1.500/38.10	.531/13.49	.429/10.90	.286/7.26	.080/2.03
1922 10461	BCL-4516-WP	---	---	1922 10460	BCL-4516-WP-PL	---	---	---	5/16"/M8	4 AWG/25mm ²	.340/8.64	1.500/38.10	.531/13.49	.429/10.90	.286/7.26	.080/2.03
1922 10383	BCL-438	---	---	1922 10232	BCL-438-PL	190820026	BCL-438-PLT	D ③	3/8"/M9	4 AWG/25mm ²	.400/10.16	1.500/38.10	.531/13.49	.429/10.90	.286/7.26	.080/2.03
1922 10458	BCL-438-WP	---	---	1922 10456	BCL-438-WP-PL	190820027	BCL-438-WP-PLT	D ③	3/8"/M9	4 AWG/25mm ²	.400/10.16	1.500/38.10	.531/13.49	.429/10.90	.286/7.26	.080/2.03
1922 10459	BCL-438-XWP	---	---	1922 10457	BCL-438-XWP-PL	---	---	---	3/8"/M9	4 AWG/25mm ²	.400/10.16	1.500/38.10	.531/13.49	.429/10.90	.286/7.26	.080/2.03
1922 10453	BCL-412	---	---	1922 10454	BCL-412-PL	---	---	---	1/2"/M12	4 AWG/25mm ²	.520/13.21	1.688/42.88	.766/19.46	.444/11.28	.286/7.26	.100/2.54
1922 10419	BCL-214	---	---	1922 10418	BCL-214-PL	190820001	BCL-214-PLT	C	1/4"/M6	2 AWG/35mm ²	.278/7.06	1.625/41.28	.625/15.88	.437/11.10	.336/8.53	.095/2.41
1922 10400	BCL-2516	---	---	1922 10233	BCL-2516-PL	190820002	BCL-2516-PLT	C	5/16"/M8	2 AWG/35mm ²	.340/8.64	1.625/41.28	.625/15.88	.437/11.10	.336/8.53	.095/2.41
1922 10380	BCL-238	---	---	1922 10235	BCL-238-PL	---	---	---	3/8"/M9	2 AWG/35mm ²	.400/10.16	1.625/41.28	.625/15.88	.437/11.10	.336/8.53	.095/2.41
1922 10564	BCL-238-WP	---	---	1922 10565	BCL-238-WP-PL	---	---	---	3/8"/M9	2 AWG/35mm ²	.400/10.16	1.625/41.28	.625/15.88	.437/11.10	.336/8.53	.095/2.41
1922 10399	BCL-212-WP	---	---	1922 10236	BCL-212-WP-PL	---	---	---	1/2"/M12	2 AWG/35mm ²	.520/13.21	1.750/44.45	.750/19.05	.474/12.04	.360/9.14	.100/2.54
1922 10594	BCL-110	---	---	1922 10595	BCL-110-PL	---	---	---	10/4.8mm	1 AWG/50mm ²	.214/5.45	1.78/43.64	.656/16.66	.446/11.33	.360/9.14	.100/2.54
1922 10421	BCL-114	---	---	1922 10420	BCL-114-PL	---	---	---	1/4"/M6	1 AWG/50mm ²	.278/7.06	1.78/43.64	.656/16.66	.446/11.33	.360/9.14	.100/2.54
1922 10396	BCL-1516	---	---	1922 10237	BCL-1516-PL	---	---	---	5/16"/M8	1 AWG/50mm ²	.340/8.64	1.78/43.64	.656/16.66	.446/11.33	.360/9.14	.100/2.54
1922 10378	BCL-138	---	---	1922 10238	BCL-138-PL	---	---	---	3/8"/M9	1 AWG/50mm ²	.400/10.16	1.78/43.64	.656/16.66	.446/11.33	.360/9.14	.100/2.54
1922 10580	BCL-138-WP	---	---	1922 10581	BCL-138-WP-PL	---	---	---	3/8"/M9	1 AWG/50mm ²	.400/10.16	1.844/46.84	.750/19.05	.474/12.04	.360/9.14	.100/2.54
1922 10395	BCL-112	---	---	1922 10239	BCL-112-PL	---	---	---	1/2"/M12	1 AWG/50mm ²	.520/13.21	1.844/46.84	.750/19.05	.474/12.04	.360/9.14	.100/2.54

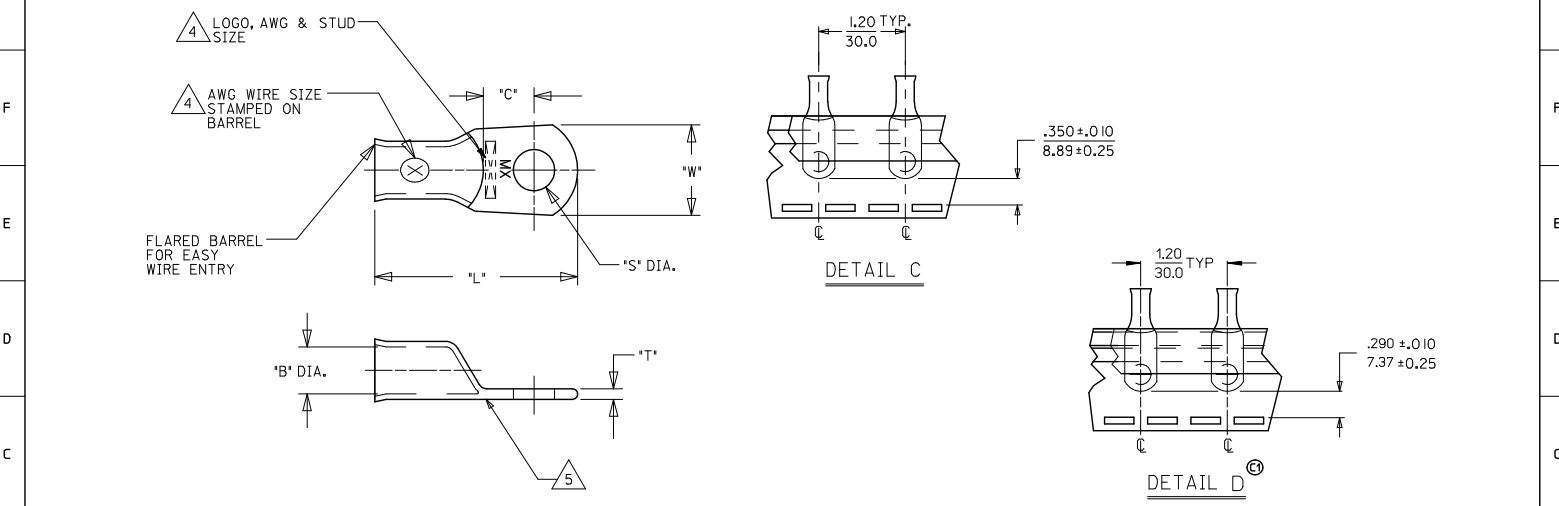

- NOTES:
- FOR INSPECTION SIGHT HOLE, PLEASE CONSULT FACTORY.
 - OTHER STUD SIZES MAY BE AVAILABLE, PLEASE CONSULT FACTORY.
 - MATERIAL: COPPER PLATING: TIN
 - MARKINGS CAN BE AT EITHER LOCATION SHOWN.
 - IF TONGUE IS TO BE BENT AT ANY ANGLE, IT MUST BE BENT AROUND A RADIUS ONE HALF THE TONGUE THICKNESS.
 - ALL PARTS ARE ROHS COMPLIANT.

TOL. METRIC DETAILS EC NO: IPG2015-0474 2017/02/21 DRAWN: THRODHAL CHKD: MALONEIL 2017/02/21 APPR: MALONEIL 2013/05/01 DESCRIPTION REV	QUALITY SYMBOLS	GENERAL TOLERANCES (UNLESS SPECIFIED)	DIMENSION STYLE	SCALE	DESIGN UNITS	THIRD ANGLE PROJECTION
	▽=0	mm INCH	IN/MM	---	INCH	③
	▽=0	4 PLACES ± ---	DRAWN BY	DATE	TITLE	
		3 PLACES ± ---	BE	06/26/02	EYELET STYLE	
	2 PLACES ± ---	CHECKED BY	DATE	COPPER TERMINALS		
	1 PLACE ± ---	HB	06/26/02	4, 2, & 1 AWG LUGS		
	ANGULAR ± ---°	APPROVED BY	DATE	MOLEX INCORPORATED		
		RD	06/26/02			
		MATERIAL NO.	DOCUMENT NO.	SHEET NO.		
		SEE CHART	SD-19221-010	1 OF 1		
		THIS DRAWING CONTAINS INFORMATION THAT IS PROPRIETARY TO MOLEX INCORPORATED AND SHOULD NOT BE USED WITHOUT WRITTEN PERMISSION				