

Excellent Integrated System Limited

Stocking Distributor

Click to view price, real time Inventory, Delivery & Lifecycle Information:

[Molex Connector Corporation](#)
[0191640814](#)

For any questions, you can email us directly:

sales@integrated-circuit.com

MATERIAL NUMBER	ENGINEERING NUMBER	MATERIAL NUMBER ON TAPE	ENGINEERING NUMBER ON TAPE	STUD SIZE	"S"	"D"	"H"	"L"	ID MIN
191640031	SB-237-04	191640941	SB-237-04T	#4	.119/3.02	.320/8.17	.527/13.39	1.45/36.8	.082/2.08
191640032	SB-237-06	191640310	SB-237-06T	#6	.146/3.71	.320/8.17	.527/13.39	1.45/36.8	.082/2.08
191640033	SB-237-08	191640311	SB-237-08T	#8	.173/4.39	.320/8.17	.527/13.39	1.45/36.8	.082/2.08
191640034	SB-237-10	191640312	SB-237-10T	#10	.198/5.03	.320/8.17	.527/13.39	1.45/36.8	.082/2.08
191640025	SB-225-10	191640940	SB-225-10T	#10	.198/5.03	.475/12.07	.338/8.59	1.63/41.4	.082/2.08
191640026	SB-225-14	191640308	SB-225-14T	1/4	.265/6.73	.475/12.07	.338/8.59	1.63/41.4	.082/2.08
191640027	SB-225-56	191640309	SB-225-56T	5/16	.328/8.33	.475/12.07	.338/8.59	1.63/41.4	.082/2.08
191640020	SB-218-38	191640307	SB-218-38T	3/8	.390/9.91	.544/13.82	.340/8.64	1.68/42.67	.082/2.08

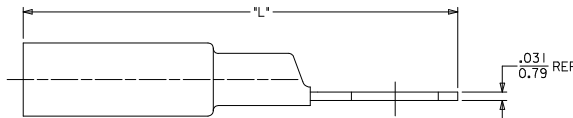
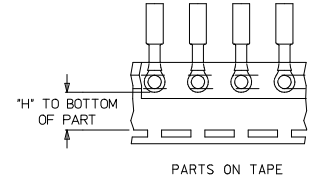
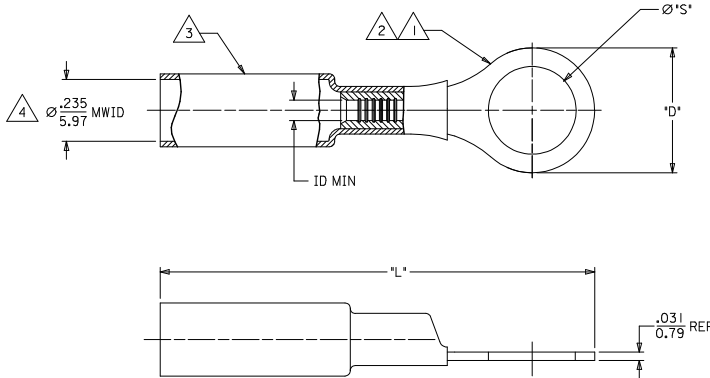

NOTE:

- 1. TERMINAL MATERIAL: COPPER ALLOY
- 2. FINISH: ELECTRO TIN PLATE.
- 3. INSULATION MATERIAL: HEAT SHRINKABLE TUBING WITH HOTMELT ADHESIVE INNER LINER. COLOR: BLUE
- 4. MWID = MAXIMUM WIRE INSULATION DIAMETER.
- 5. PARTS ARE RoHS COMPLIANT.

SALES DRAWING

CORRECTED IN MIN EC NO: IPG2015-1941 DRAWING: JASOT 2013/06/13 CHKD: MALCNET 2013/06/13 APPR: MALCNET 2013/07/09	QUALITY SYMBOLS ▽=0 ▽=0	GENERAL TOLERANCES (UNLESS SPECIFIED)		DIMENSION STYLE		SCALE	DESIGN UNITS	THIRD ANGLE PROJECTION	
				IN/MM		---	INCH		
		4 PLACES	±---	±---	DRAWN BY	DATE	TITLE		
		3 PLACES	±---	±---	BENDERLE	2002/08/26	RING TONGUE TERMINAL PERMA-SEAL NIAC 16-14 AWG		
2 PLACES	±---	±---	CHECKED BY	DATE	MOLEX INCORPORATED				
1 PLACE	±---	±---	HBEITZEL	2002/08/26					
ANGULAR ±---		°	APPROVED BY	DATE	DOCUMENT NO.		SHEET NO.		
			RDEROSS	2002/08/26	SD-19164-026		1 OF 1		
DRAFT WHERE APPLICABLE MUST REMAIN WITHIN DIMENSIONS		SEE CHART		THIS DRAWING CONTAINS INFORMATION THAT IS PROPRIETARY TO MOLEX INCORPORATED AND SHOULD NOT BE USED WITHOUT WRITTEN PERMISSION					