

Excellent Integrated System Limited

Stocking Distributor

Click to view price, real time Inventory, Delivery & Lifecycle Information:

[Molex Connector Corporation](#)
[0192210769](#)

For any questions, you can email us directly:

sales@integrated-circuit.com

UNPLATED MATERIAL NUMBER	UNPLATED ENG. NUMBER	PLATED MATERIAL NUMBER	PLATED ENGINEERING NUMBER	STUD SIZE	AWG WIRE RANGE	*S*	*L*	*W*	*C*	*B*	*T*
						±.015/(0.38)	±.100/(2.54)	±.035/(0.89)	±.050/(1.27)	±.020/(0.51)	±.020/(0.50)
192210423	BCL-1014	192210422	BCL-1014-PL	1/4/(6.4)	1/0	.278/(7.06)	1.844/(46.84)	.728/(18.49)	.460/(11.68)	.400/(10.16)	.110/(2.80)
192210394	BCL-10516	192210240	BCL-10516-PL	5/16/(7.9)	1/0	.340/(8.64)	1.844/(46.84)	.728/(18.49)	.460/(11.68)	.400/(10.16)	.110/(2.80)
192210377	BCL-1038	192210241	BCL-1038-PL	3/8/(9.5)	1/0	.400/(10.16)	1.844/(46.84)	.728/(18.49)	.460/(11.68)	.400/(10.16)	.110/(2.80)
192210441	BCL-1038-WP	192210440	BCL-1038-WP-PL	3/8/(9.5)	1/0	.400/(10.16)	1.906/(48.41)	.813/(20.65)	.442/(11.23)	.400/(10.16)	.110/(2.80)
192210393	BCL-1012	192210242	BCL-1012-PL	1/2/(12.7)	1/0	.520/(13.21)	1.844/(46.84)	.728/(18.49)	.460/(11.68)	.400/(10.16)	.110/(2.80)
192210437	BCL-1012-WP	192210436	BCL-1012-WP-PL	1/2/(12.7)	1/0	.520/(13.21)	1.906/(48.41)	.813/(20.65)	.442/(11.23)	.400/(10.16)	.110/(2.80)
192210249	BCL-2014	192210234	BCL-2014-PL	1/4/(6.4)	2/0	.278/(7.06)	2.062/(52.37)	.824/(20.93)	.522/(13.26)	.461/(11.71)	.110/(2.80)
192210398	BCL-20516	192210243	BCL-20516-PL	5/16/(7.9)	2/0	.340/(8.64)	2.062/(52.37)	.824/(20.93)	.522/(13.26)	.461/(11.71)	.110/(2.80)
192210379	BCL-2038	192210244	BCL-2038-PL	3/8/(9.5)	2/0	.400/(10.16)	2.062/(52.37)	.824/(20.93)	.522/(13.26)	.461/(11.71)	.110/(2.80)
192210397	BCL-2012	192210245	BCL-2012-PL	1/2/(12.7)	2/0	.520/(13.21)	2.062/(52.37)	.824/(20.93)	.522/(13.26)	.461/(11.71)	.110/(2.80)
192210597	BCL-2058	192210598	BCL-2058-PL	5/8/(15.9)	2/0	.656/(16.66)	2.062/(52.37)	.824/(20.93)	.522/(13.26)	.461/(11.71)	.110/(2.80)
192210478	BCL-3014	192210570	BCL-3014-PL	1/4/(6.4)	3/0	.278/(7.06)	2.156/(54.76)	.916/(23.27)	.501/(12.73)	.511/(12.93)	.115/(2.92)
192210402	BCL-30516	192210246	BCL-30516-PL	5/16/(7.9)	3/0	.340/(8.64)	2.156/(54.76)	.916/(23.27)	.501/(12.73)	.511/(12.93)	.115/(2.92)
192210381	BCL-3038	192210247	BCL-3038-PL	3/8/(9.5)	3/0	.400/(10.16)	2.156/(54.76)	.916/(23.27)	.501/(12.73)	.511/(12.93)	.115/(2.92)
192210401	BCL-3012	192210248	BCL-3012-PL	1/2/(12.7)	3/0	.520/(13.21)	2.156/(54.76)	.916/(23.27)	.501/(12.73)	.511/(12.93)	.115/(2.92)
192210502	BCL-40516(.625)	192210503	BCL-40516-PL(.625)	5/16/(7.9)	4/0	.340/(8.63)	2.688/(68.28)	1.099/(27.91)	.557/(14.15)	.625/(15.88)	.135/(3.43)
192210374	BCL-4038(.625)	192210371	BCL-4038-PL(.625)	3/8/(9.5)	4/0	.400/(10.16)	2.688/(68.28)	1.099/(27.91)	.557/(14.15)	.625/(15.88)	.135/(3.43)
192210375	BCL-4012(.625)	192210372	BCL-4012-PL(.625)	1/2/(12.7)	4/0	.520/(13.21)	2.688/(68.28)	1.099/(27.91)	.557/(14.15)	.625/(15.88)	.135/(3.43)
192210376	BCL-4058(.625)	192210373	BCL-4058-PL(.625)	5/8/(15.9)	4/0	.656/(16.66)	2.688/(68.28)	1.099/(27.91)	.557/(14.15)	.625/(15.88)	.135/(3.43)
192210413	BCL-40516	192210412	BCL-40516-PL	5/16/(7.9)	4/0	.340/(8.63)	2.344/(59.54)	.999/(25.37)	.550/(13.97)	.559/(14.20)	.135/(3.43)
192210382	BCL-4038	192210250	BCL-4038-PL	3/8/(9.5)	4/0	.400/(10.16)	2.344/(59.54)	.999/(25.37)	.550/(13.97)	.559/(14.20)	.135/(3.43)
192210403	BCL-4012	192210251	BCL-4012-PL	1/2/(12.7)	4/0	.520/(13.21)	2.344/(59.54)	.999/(25.37)	.550/(13.97)	.559/(14.20)	.135/(3.43)
192210446	BCL-25038	192210447	BCL-25038-PL	3/8/(9.5)	250	.400/(10.16)	2.656/(67.46)	1.203/(30.56)	.676/(17.17)	.685/(17.40)	.125/(3.18)
192210652	BCL-4014	192210648	BCL-4014-PL	1/4/(6.4)	4/0	.278/(7.06)	2.344/(59.54)	.984/(24.99)	.550/(13.97)	.559/(13.97)	.135/(3.43)
-	-	192210847	BCL-1010MM-PL	10mm	1/0	.417/(10.59)	1.844/(46.84)	.728/(18.49)	.460/(11.68)	.400/(10.16)	.110/(2.80)
-	-	192210848	BCL-2010MM-PL	10mm	2/0	.417/(10.59)	2.062/(52.37)	.824/(20.93)	.522/(13.26)	.461/(11.71)	.110/(2.80)
-	-	192210862	BCL-3010MM-PL	10mm	3/0	.417/(10.59)	2.156/(54.76)	.916/(23.27)	.501/(12.73)	.511/(12.93)	.115/(2.92)

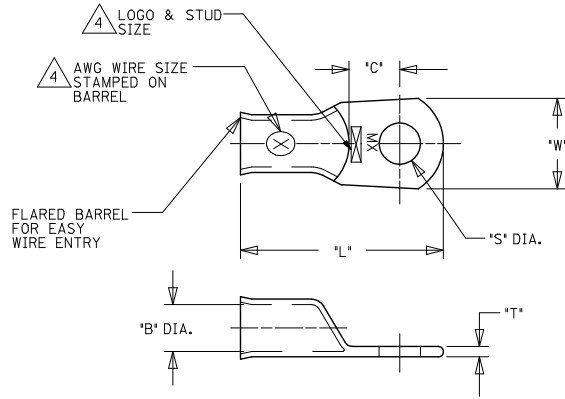

SALES DRAWING

- NOTES:
- FOR INSPECTION SIGHT HOLE, PLEASE CONSULT FACTORY.
 - OTHER STUD SIZES MAY BE AVAILABLE, PLEASE CONSULT FACTORY.
 - MATERIAL: COPPER PLATING: TIN
 - MARKINGS CAN BE AT EITHER LOCATION SHOWN.
 - IF TONGUE IS TO BE BENT AT ANY ANGLE, IT MUST BE BENT AROUND A RADIUS ONE HALF THE TONGUE THICKNESS.
 - USE .625/(15.88) BARREL I.D. FOR HIGH STRAND WELDING CABLE.

ADD MATL # BCL-0586(.625) EC NO: IPG20/6-0026 DRAWN BY: JASOT 2015/07/06 CHKD: JALONEIL 2015/07/06 APPR: JALONEIL 2015/07/13 DESCRIPTION:	QUALITY SYMBOLS	GENERAL TOLERANCES (UNLESS SPECIFIED)	DIMENSION STYLE	SCALE	DESIGN UNITS	THIRD ANGLE PROJECTION
	$\nabla=0$ $\nabla=0$	4 PLACES ±--- INCH 3 PLACES ±--- ±.005 2 PLACES ±0.13 ±.01 1 PLACE ±0.25 ±--- ANGULAR ±---°	IN/MM DRAWN BY: BRE DATE: 2002/06/24 CHECKED BY: HEB DATE: 2002/06/24 APPROVED BY: RWD DATE: 2002/06/24	INCH TITLE: BATTERY CABLE LUG COPPER TERMINALS 1/0, 2/0, 3/0 & 4/0	--- INCH	
	DRAFT WHERE APPLICABLE MUST REMAIN WITHIN DIMENSIONS	SEE CHART SIZE C	MATERIAL NO. MOLEX INCORPORATED DOCUMENT NO. SD-19221-011	SHEET NO. 1 OF 1		
	THIS DRAWING CONTAINS INFORMATION THAT IS PROPRIETARY TO MOLEX INCORPORATED AND SHOULD NOT BE USED WITHOUT WRITTEN PERMISSION					