

Excellent Integrated System Limited

Stocking Distributor

Click to view price, real time Inventory, Delivery & Lifecycle Information:

[Molex Connector Corporation](#)
[0424920321](#)

For any questions, you can email us directly:
sales@integrated-circuit.com

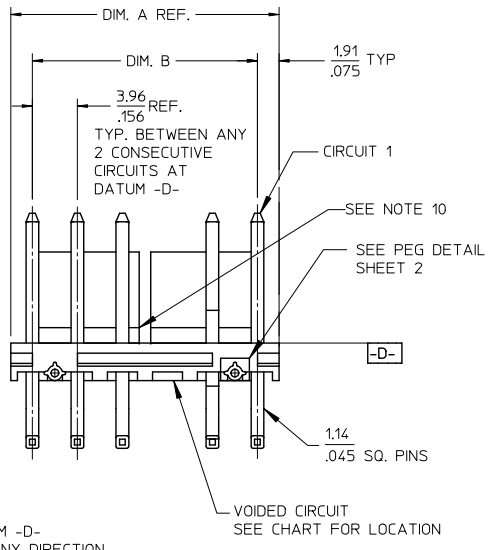
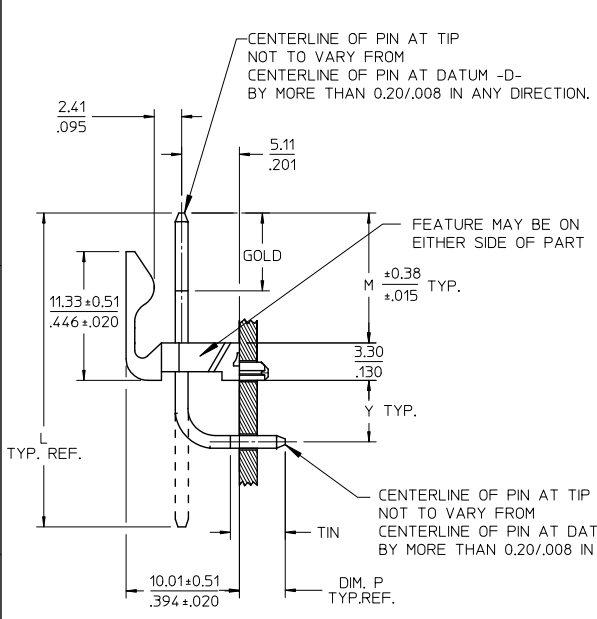

NO. OF CKTS.	DIM. A	DIM. B	SLOT LOC BETWEEN CKTS
2	7.77 .306	3.96±0.05 .156±0.002	NONE
3	11.73 .462	7.92±0.08 .312±0.003	NONE
4	15.70 .618	11.89±0.08 .468±0.003	NONE
5	19.66 .774	15.85±0.10 .624±0.004	NONE
6	23.62 .930	19.81±0.10 .780±0.004	3 & 4
7	27.58 1.086	23.77±0.10 .936±0.004	4 & 5
8	31.55 1.242	27.74±0.13 1.092±0.005	4 & 5
9	35.51 1.398	31.70±0.13 1.248±0.005	5 & 6
10	39.47 1.554	35.66±0.13 1.404±0.005	5 & 6
11	43.43 1.710	39.62±0.15 1.560±0.006	6 & 7
12	47.40 1.866	43.59±0.15 1.716±0.006	4 & 5 8 & 9

REMOVE PEG DIMS EC NO: UCP2012-2438 DRWN: J JAGUILAR 2012/02/02 CHKD: KKIPPER 2012/02/21 APPR: F SMITH 2012/02/24	QUALITY SYMBOLS	GENERAL TOLERANCES (UNLESS SPECIFIED)		DIMENSION STYLE MM/IN		SCALE 2:1	DESIGN UNITS INCH	THIRD ANGLE PROJECTION
	▽=0	4 PLACES ± ---	± ---	DRAWN BY JSCHAFFER	DATE 11-25-03	TITLE KK .156 HEADER ASSEMBLY FRICTION LOCK RT ANGLE WITH PEGS MOLEX INCORPORATED DOCUMENT NO. SD-42492-001 SHEET NO. 1 OF 7		
	▽=0	3 PLACES ± ---	± .010	CHECKED BY SAMIEC	DATE 11-26-03			
	▽=0	2 PLACES ± 0.25	± .015	APPROVED BY MARGULIS	DATE 12-1-03			
▽=0	1 PLACE ± 0.38	± ---	MATERIAL NO.					
		ANGULAR ± 1/2°		SEE CHART				
		DRAFT WHERE APPLICABLE MUST REMAIN WITHIN DIMENSIONS		THIS DRAWING CONTAINS INFORMATION THAT IS PROPRIETARY TO MOLEX INCORPORATED AND SHOULD NOT BE USED WITHOUT WRITTEN PERMISSION				

ib_frame_A_P_AM_T
Rev. F 2009/06/18

5 4 3 2 1

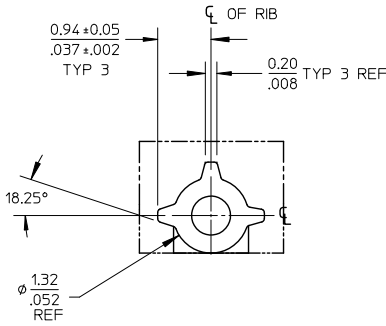

PEG DETAIL
SCALE 10:1

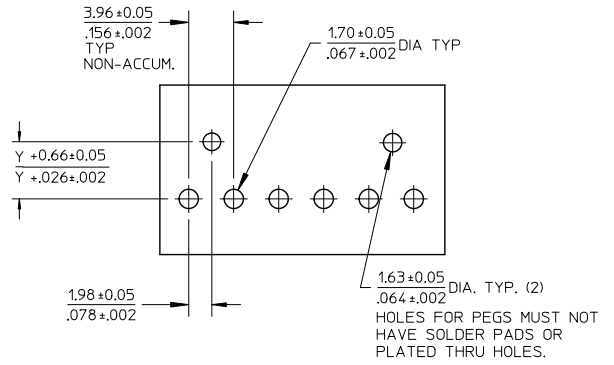

RECOMMENDED PC BOARD HOLE LAYOUT

NOTES:

1. MATERIAL: HEADER-POLYESTER, 94V-0, MOLDED NATURAL (WHITE)
PINS: BRASS
2. FINISHES: (154) OVERALL TIN 0.00254/.000100 MIN.
OVER 0.00127/.000050 MIN. NICKEL.
(197) OVERALL REFLOWED MATTE TIN: 0.00152/.000060 MIN.
OVER 0.00127/.000050 MIN. NICKEL OVERALL.
(208) SELECT GOLD 0.00038/.000015 MIN.
SELECT TIN 0.00254/.000100 MIN.
OVERALL NICKEL UNDERPLATE 0.00127/.000050 MIN.
(228) SELECT GOLD 0.00076/.000030 MIN.
SELECT TIN 0.00254/.000100 MIN.
OVERALL NICKEL UNDERPLATE 0.00127/.000050 MIN.
(241) SELECT GOLD: 0.00051/.000020 MIN.
SELECT TIN: 0.00254/.000100 MIN.
OVERALL NICKEL UNDERPLATE: 0.00127/.000050 MIN.
3. PRODUCT SPECIFICATION: SEE PS-08-50.
4. PACKAGING INFO: SEE TABLES.
5. SOLDERABILITY: PER SMES-152.
6. PIN PUSH OUT FORCE: PRIOR TO SOLDERING, A 3 LB MINIMUM FORCE (IN EITHER DIRECTION) SHALL BE REQUIRED TO PUSH THE PIN OUT OF THE HEADER.
7. PARTS ARE STACKABLE END TO END ON 3.96/.156 CENTERS.
8. FOR PART WITHOUT PEGS SEE 41792.
9. THIS PART CONFORMS TO CLASS B REQUIREMENTS OF COSMETIC SPECIFICATION PS-45499-002.
10. SLOTS ON BACKWALL ARE BETWEEN CIRCUITS. SEE CHART FOR LOCATION.

SEE SHEET 1	EC NO: UCP2012-2438	QUALITY SYMBOLS	GENERAL TOLERANCES (UNLESS SPECIFIED)		DIMENSION STYLE		SCALE	DESIGN UNITS	THIRD ANGLE PROJECTION
	DRWN: J JAGUILAR		mm	INCH	1:1	INCH			
	CHKD: MK IPPER		DRAWN BY JSCHAFFER		DATE 11-25-03		TITLE		
	APPR: F SMITH		CHECKED BY SAMIEC		DATE 11-26-03		KK .156 HEADER ASSEMBLY FRICTION LOCK RT ANGLE WITH PEGS		
REV G1	DRAFT WHERE APPLICABLE MUST REMAIN WITHIN DIMENSIONS		APPROVED BY MARGULIS		DATE 12-1-03		Molex MOLEX INCORPORATED		
			MATERIAL NO.		SEE CHART		DOCUMENT NO.	SD-42492-001	
			SIZE A		THIS DRAWING CONTAINS INFORMATION THAT IS PROPRIETARY TO MOLEX INCORPORATED AND SHOULD NOT BE USED WITHOUT WRITTEN PERMISSION				

tb_frame_A_P_AM_T
Rev. F 2009/06/18

5

4

3

2

1