

Excellent Integrated System Limited

Stocking Distributor

Click to view price, real time Inventory, Delivery & Lifecycle Information:

[Molex Connector Corporation](#)
[0440680256](#)

For any questions, you can email us directly:

sales@integrated-circuit.com

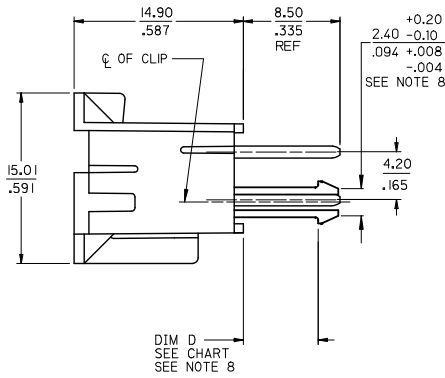
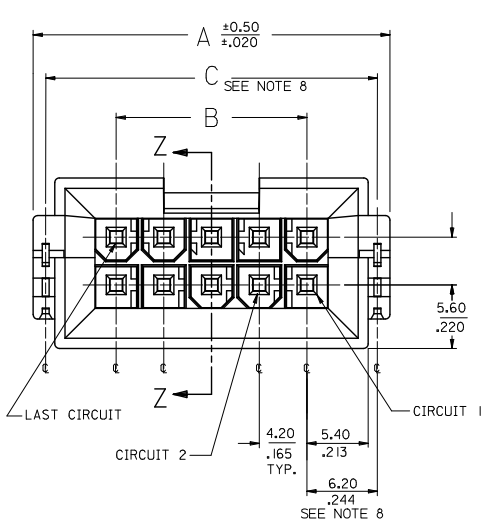

NOTES:

- 1) MATERIALS:
HOUSING: PA46 FILLED BLACK, UL94V-0
TERMINAL: BRASS
BOARD RETENTION CLIP: BRASS
- 2) FINISHES:
1 = 0.00254/(.000100) MIN TIN OVER NICKEL
2 = 0.00076/(.000030) MIN. SELECT GOLD AND 0.00254/(.000100) MIN. SELECT MATTE TIN OVER 0.00127/(.000050) MIN. NICKEL OVERALL
- 3) PRODUCT SPECIFICATIONS: PS-43810-001
- 4) PACKAGING SPECIFICATION: PK-43879-002
- 5) PART MATES WITH MOLEX RECEPTACLE #5557 AND #42474, AND #44516 AND #42385 HEADER.
- 6) PART ALLOWS FOR 1.27/.050 MAX. MIS-ALIGNMENT WITH MATING HOUSINGS IN ANY DIRECTION.
- 7) CONNECTOR ASSEMBLIES ARE NOT TO BE MATED AND UNMATED WHILE CIRCUITS ARE LIVE.
- 8) THIS DIMENSION DOES NOT APPLY TO PARTS WITHOUT P.C. BOARD RETENTION CLIPS.
- 9) THIS PART CONFORMS TO CLASS B REQUIREMENTS OF COSMETIC SPECIFICATION PS-45499-002.
- 10) DISCOLORATION IN THE BANDOLIER CARRIER AREA OF THE PIN IS INHERENT TO THE PLATING PROCESS AND IS DUE TO THE MASKING EFFECT OF THE CARRIER. THIS DISCOLORATION IS IN A NON-FUNCTIONAL AREA OF THE PIN AND WILL NOT AFFECT THE PERFORMANCE OF THE HEADER ASSEMBLY.

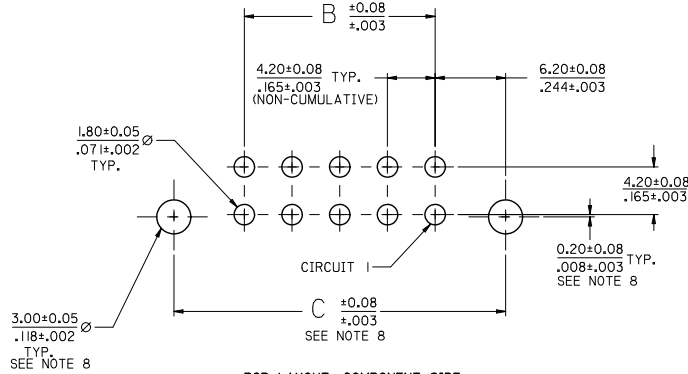
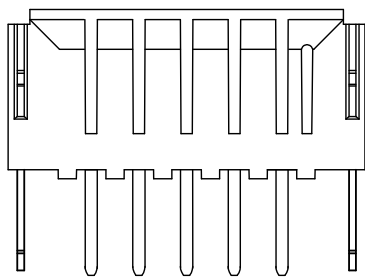

CKTS	DIM. 'A'	DIM. 'B'	DIM. 'C'
4	18.81 .740	4.20 .165	16.60 .653
6	23.01 .906	8.40 .331	20.80 .819
8	27.21 1.071	12.60 .496	25.00 .984
10	31.41 1.237	16.80 .661	29.20 1.150
12	35.61 1.402	21.00 .828	33.40 1.315
14	39.81 1.567	25.20 .992	37.60 1.480
16	44.01 1.733	29.40 1.157	41.80 1.646
18	48.21 1.898	33.60 1.323	46.00 1.811
20	52.41 2.063	37.80 1.488	50.20 1.976
22	56.61 2.229	42.00 1.654	54.40 2.142
24	60.81 2.394	46.20 1.819	58.60 2.307

PCB LAYOUT: COMPONENT SIDE
RECOMMENDED PCB THICKNESS: SEE CHART

CHANGE PLATING EC NO: UCP2012-1560 DRAWN BY: 2012/01/09 CHK'D BY: 2012/01/09 APPR'D BY: 2012/02/02	QUALITY SYMBOLS ∇=0 ∇=0 ∇=0	GENERAL TOLERANCES (UNLESS SPECIFIED) mm INCH 4 PLACES ± --- ± --- 3 PLACES ± --- ± .010 2 PLACES ± 0.25 ± .014 1 PLACE ± 0.35 ± --- ANGULAR ±1/2°	DIMENSION STYLE MM/IN	SCALE 4:1 DESIGN UNITS METRIC THIRD ANGLE PROJECTION	MINI-FIT JR BMI SMC VERTICAL HEADER ASM FOR 6.35/.250 THK PCB MOLEX INCORPORATED	MATERIAL NO. SEE SHEET 2 DOCUMENT NO. SD-44068-061	SHEET NO. 1 OF 2	
								DRAWN BY: JI WANG DATE: 2000/07/27 CHECKED BY: BANDURA DATE: 2000/07/27 APPROVED BY: F SMITH DATE: 2011/11/11
								DRAFT WHERE APPLICABLE MUST REMAIN WITHIN DIMENSIONS
								THIS DRAWING CONTAINS INFORMATION THAT IS PROPRIETARY TO MOLEX INCORPORATED AND SHOULD NOT BE USED WITHOUT WRITTEN PERMISSION

FINISH:	1 (SEE NOTE 2)
DIM. D:	WITHOUT CLIP
PCB THICKNESS:	(6.35±0.18) .250±.007
CIRCUITS	MATERIAL NO.
04	44068-0244
06	44068-0245
08	X 44068-0246
10	44068-0247
12	X 44068-0248
14	44068-0249
16	X 44068-0250
18	44068-0251
20	X 44068-0252
22	X 44068-0253
24	44068-0254

FINISH:	1 (SEE NOTE 2)
DIM. D:	(6.60±0.25) .260±.010
PCB THICKNESS:	(6.35±0.18) .250±.007
CIRCUITS	MATERIAL NO.
04	44068-0266
06	44068-0267
08	X 44068-0268
10	44068-0269
12	X 44068-0270
14	44068-0271
16	X 44068-0272
18	44068-0273
20	X 44068-0274
22	X 44068-0275
24	44068-0276

FINISH:	2 (SEE NOTE 2)
DIM. D:	WITHOUT CLIP
PCB THICKNESS:	(6.35±0.18) .250±.007
CIRCUITS	MATERIAL NO.
04	44068-0255
06	44068-0256
08	X 44068-0257
10	44068-0258
12	X 44068-0259
14	44068-0260
16	X 44068-0261
18	44068-0262
20	X 44068-0263
22	X 44068-0264
24	44068-0265

FINISH:	2 (SEE NOTE 2)
DIM. D:	(6.60±0.25) .260±.010
PCB THICKNESS:	(6.35±0.18) .250±.007
CIRCUITS	MATERIAL NO.
04	44068-0277
06	44068-0278
08	X 44068-0279
10	44068-0280
12	X 44068-0281
14	44068-0282
16	X 44068-0283
18	44068-0284
20	X 44068-0285
22	X 44068-0286
24	44068-0287

X PRECEDING PART NUMBER DESIGNATES
CIRCUIT SIZE IS NOT TOOLED
PLEASE CONTACT FACTORY

SEE SHEET 1 EC NO: UCP2072-1560 DRAWN BY: 2017/01/09 CHKD: BELL APPR: SMITH 2017/02/02	QUALITY SYMBOLS 	GENERAL TOLERANCES (UNLESS SPECIFIED)		DIMENSION STYLE		SCALE	DESIGN UNITS	THIRD ANGLE PROJECTION MINI-FIT JR BMI SMC VERTICAL HEADER ASM FOR 6.35/.250 THK PCB MOLEX INCORPORATED
				MM/IN		1:1	METRIC	
		4 PLACES ± --- ± ---	DRAWN BY	DATE		TITLE		
		3 PLACES ± --- ± .010	J1 WANG	2000/07/27		SD-44068-061		
2 PLACES ± 0.25 ± .014	CHECKED BY	DATE		SHEET NO.				
1 PLACE ± 0.35 ± ---	BANDURA	2000/07/27		2 OF 2				
ANGULAR ± 1/2°	APPROVED BY	DATE		MATERIAL NO.				
	SMITH	2011/11/11		DOCUMENT NO.				
DRAFT WHERE APPLICABLE MUST REMAIN WITHIN DIMENSIONS		SEE CHART		SD-44068-061				
		SIZE		THIS DRAWING CONTAINS INFORMATION THAT IS PROPRIETARY TO MOLEX INCORPORATED AND SHOULD NOT BE USED WITHOUT WRITTEN PERMISSION				