



Distributor of Molex Connector Corporation: Excellent Integrated System Limited
Datasheet of 0387217010 - Connector Barrier Block Strip 10 Circuit 0.375" (9.53mm)

Contact us: sales@integrated-circuit.com Website: www.integrated-circuit.com

Excellent Integrated System Limited

Stocking Distributor

Click to view price, real time Inventory, Delivery & Lifecycle Information:

[Molex Connector Corporation](#)
[0387217010](#)

For any questions, you can email us directly:

sales@integrated-circuit.com

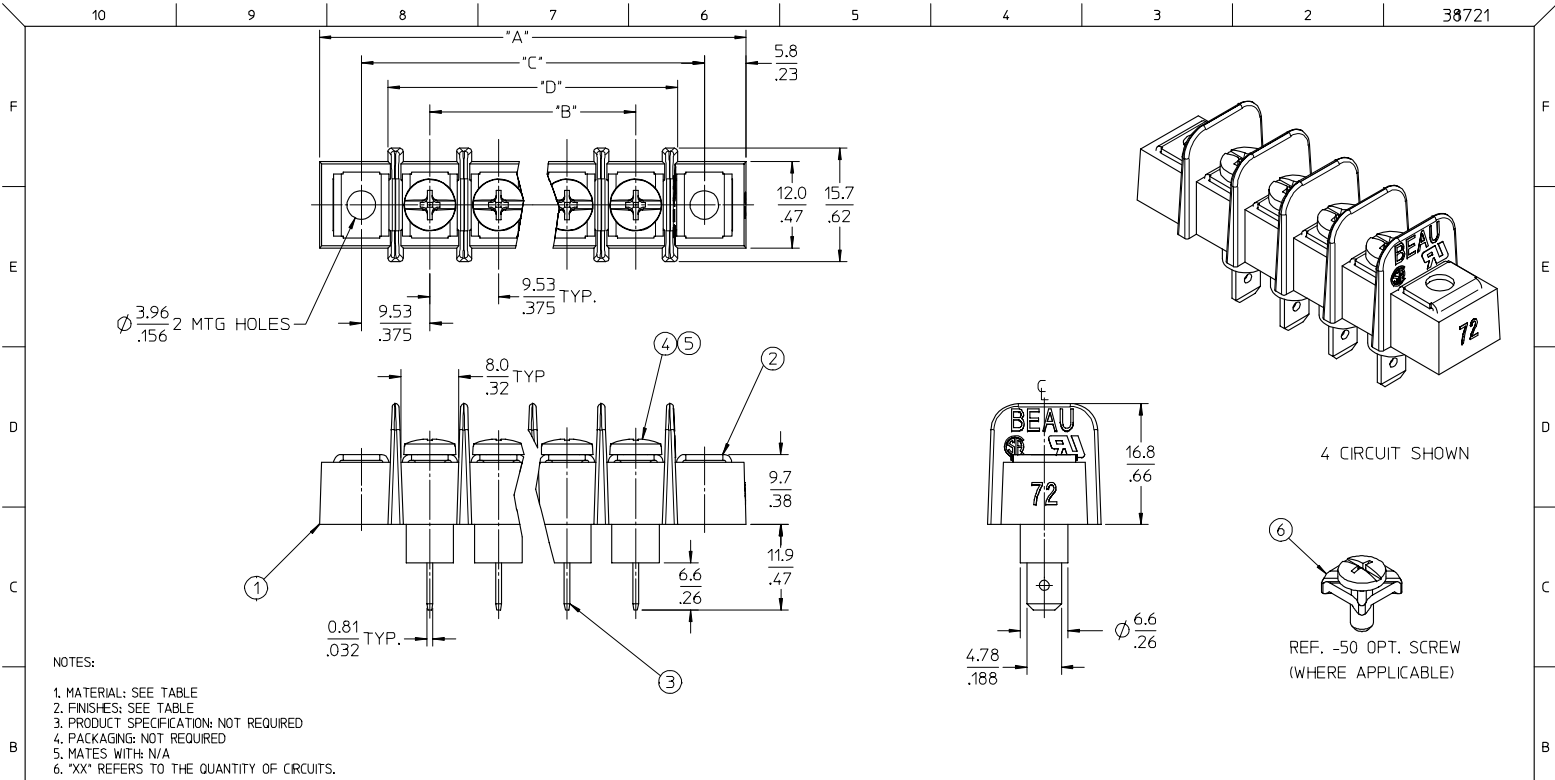

- NOTES:
1. MATERIAL: SEE TABLE
 2. FINISHES: SEE TABLE
 3. PRODUCT SPECIFICATION: NOT REQUIRED
 4. PACKAGING: NOT REQUIRED
 5. MATES WITH: N/A
 6. *XX* REFERS TO THE QUANTITY OF CIRCUITS.

ITEM	QTY.	DESCRIPTION	MATERIAL	FINISH
6	XX	SCREW&WASHER, #6-32X.250 PAN, PH-SL, -50	STEEL	ZN, CLEAR CHROMATE
5	XX	SCREW, #6-32X.250 BHD, PHIL-SLOT, -49	BRASS	NICKEL PLATE
4	XX	SCREW, #6-32X.250 BHD, PHIL-SLOT (STD.)	STEEL	ZN, CLEAR CHROMATE
3	XX	TERMINAL, FAST TAB, STYLE 9, SN/B	BRASS	TIN PLATE
2	2	PLATE, MOUNTING, NI	BRASS	NICKEL PLATE
1	1	INSULATOR, 9.53MM, SR BTS, INSUL. BASE	PBT, 30% GF	BLACK

RELEASED EC NO: ETC2006-0262 2006/02/16	DRW: C. YORK 2006/02/16	CHK: RDEROSS 2006/02/16	APP: RDEROSS 2006/02/16	DESCRIPTION	QUALITY SYMBOLS ▽=0 ▽=0	GENERAL TOLERANCES (UNLESS SPECIFIED)	DIMENSION STYLE MM/IN	SCALE 2:1	DESIGN UNITS INCH	THIRD ANGLE PROJECTION	
						4 PLACES ± .0025 ± .0002	DRAWN BY C. YORK	DATE 2006/02/16	TITLE 9.53 [.375] SR BTS ASY, INSUL. FT, W/MTG		
						3 PLACES ± 0.005 ± .005	CHECKED BY RDEROSS	DATE 2006/02/16	MOLEX INCORPORATED		
						2 PLACES ± 0.13 ± .01	APPROVED BY RDEROSS	DATE 2006/02/16	DOCUMENT NO. SD-38721-002		
						1 PLACE ± 0.25 ± .---	MATERIAL NO. SIZE B		SHEET NO. 1 OF 2		
						DRAFT WHERE APPLICABLE MUST REMAIN WITHIN DIMENSIONS		THIS DRAWING CONTAINS INFORMATION THAT IS PROPRIETARY TO MOLEX INCORPORATED AND SHOULD NOT BE USED WITHOUT WRITTEN PERMISSION			

10 9 8 7 6 5 4 3 2 38721

NUMBER OF CIRCUITS *XX*	DIM. *A*		DIM. *B*		DIM. *C*		DIM. *D*		ASSEMBLY MATERIAL NO. (STD)	ASSEMBLY MATERIAL NO. (OPT -49)	ASSEMBLY MATERIAL NO. (OPT -50)
02	40.2	(1.58)	9.53	(.375)	28.58	(1.125)	21.1	(.83)	387216702	387217002	387217302
03	49.7	(1.96)	19.05	(.750)	38.10	(1.500)	30.7	(1.21)	387216703	387217003	387217303
04	59.2	(2.33)	28.58	(1.125)	47.63	(1.875)	40.2	(1.58)	387216704	387217004	387217304
05	68.7	(2.71)	38.10	(1.500)	57.15	(2.250)	49.7	(1.96)	387216705	387217005	387217305
06	78.3	(3.08)	47.63	(1.875)	66.68	(2.625)	59.2	(2.33)	387216706	387217006	387217306
07	87.8	(3.46)	57.15	(2.250)	76.20	(3.000)	68.8	(2.71)	387216707	387217007	387217307
08	97.3	(3.83)	66.68	(2.625)	85.73	(3.375)	78.3	(3.08)	387216708	387217008	387217308
09	106.8	(4.21)	76.20	(3.000)	95.25	(3.750)	87.8	(3.46)	387216709	387217009	387217309
10	116.4	(4.58)	85.73	(3.375)	104.78	(4.125)	97.3	(3.83)	387216710	387217010	387217310
11	125.9	(4.96)	95.25	(3.750)	114.30	(4.500)	106.9	(4.21)	387216711	387217011	387217311
12	135.4	(5.33)	104.78	(4.125)	123.83	(4.875)	116.4	(4.58)	387216712	387217012	387217312
13	144.9	(5.71)	114.30	(4.500)	133.35	(5.250)	125.9	(4.96)	387216713	387217013	387217313
14	154.5	(6.08)	123.83	(4.875)	142.88	(5.625)	135.4	(5.33)	387216714	387217014	387217314
15	164.0	(6.46)	133.35	(5.250)	152.40	(6.000)	145.0	(5.71)	387216715	387217015	387217315
16	173.5	(6.83)	142.88	(5.625)	161.93	(6.375)	154.5	(6.08)	387216716	387217016	387217316
17	183.0	(7.21)	152.40	(6.000)	171.45	(6.750)	164.0	(6.46)	387216717	387217017	387217317
18	192.6	(7.58)	161.93	(6.375)	180.98	(7.125)	173.5	(6.83)	387216718	387217018	387217318
19	202.1	(7.96)	171.45	(6.750)	190.50	(7.500)	183.1	(7.21)	387216719	387217019	387217319
20	211.6	(8.33)	180.98	(7.125)	200.03	(7.875)	192.6	(7.58)	387216720	387217020	387217320
21	221.1	(8.71)	190.50	(7.500)	209.55	(8.250)	202.1	(7.96)	387216721	387217021	387217321
22	230.7	(9.08)	200.03	(7.875)	219.08	(8.625)	211.6	(8.33)	387216722	387217022	387217322
23	240.2	(9.46)	209.55	(8.250)	228.60	(9.000)	221.2	(8.71)	387216723	387217023	387217323
24	249.7	(9.83)	219.08	(8.625)	238.13	(9.375)	230.7	(9.08)	387216724	387217024	387217324
25	259.2	(10.21)	228.60	(9.000)	247.65	(9.750)	240.2	(9.46)	387216725	387217025	387217325
26	268.8	(10.58)	238.13	(9.375)	257.18	(10.125)	249.7	(9.83)	387216726	387217026	387217326

NOTES:

1. INCH DIMENSIONS SHOWN IN BRACKETS [XX].

SEE SHEET 1 IEC NO. EIC2006-0262 DRAWN BY C. YORK CHECKED BY RDEROSS APPROVED BY RDEROSS DATE 2006/02/16 DATE 2006/02/16 DATE 2006/02/16	QUALITY SYMBOLS ▽=0 ▽=0	GENERAL TOLERANCES (UNLESS SPECIFIED)		DIMENSION STYLE		SCALE	DESIGN UNITS	THIRD ANGLE PROJECTION	
				MM/IN		1:1	INCH		
				DRAWN BY C. YORK		DATE 2006/02/16		TITLE 9.53 [.375] SR BTS ASY, INSUL. FT, W/MTG	
				CHECKED BY RDEROSS		DATE 2006/02/16		MATERIAL NO. MOLEX INCORPORATED	
		APPROVED BY RDEROSS		DATE 2006/02/16		DOCUMENT NO. SD-38721-002		SHEET NO. 2 OF 2	
		ANGULAR ± 1 °		MATERIAL NO. SEE CHART		THIS DRAWING CONTAINS INFORMATION THAT IS PROPRIETARY TO MOLEX INCORPORATED AND SHOULD NOT BE USED WITHOUT WRITTEN PERMISSION			

9 8 7 6 5 4 3 2 1