

Excellent Integrated System Limited

Stocking Distributor

Click to view price, real time Inventory, Delivery & Lifecycle Information:

[Maxim Integrated](#)
[MAX14758EUE+](#)

For any questions, you can email us directly:

sales@integrated-circuit.com

MAX14756/MAX14757/ MAX14758

Quad SPST +70V Analog Switches

General Description

The MAX14756/MAX14757/MAX14758 are analog switches with a low on-resistance of 10Ω (max) that conduct equally well in both directions. All devices have a rail-to-rail analog-signal range. They operate with a single +10V to +70V supply in unipolar applications or ±35V dual supplies in bipolar applications. The bipolar supplies can be offset and do not have to be symmetrical.

The MAX14756 is a quad normally closed (NC) single-pole/single-throw (SPST) switch, the MAX14757 is a quad normally open (NO) SPST switch, and the MAX14758 has two NO and two NC SPST switches. These switches have 5Ω (typ) on-resistances and low on-leakage currents of 0.01nA (typ). The on-resistance flatness is 0.004Ω (typ).

The devices are suitable for a multitude of analog signal routing and switching applications. They are specified over an extended temperature range of -40°C to +85°C, but can be operated up to +125°C with elevated leakage currents.

Applications

- Industrial Control Systems
- Instrumentation
- Battery Management
- Environmental Control Systems
- Medical Systems
- ATE System
- Audio Signal Routing/Switching

Features

- Single-Supply Operation from +10V to +70V
- Bipolar-Supply Operation Up to ±35V
- On-Resistance of 10Ω (max)
- R_{ON} Flatness of 0.004Ω (typ)
- 2.5nA (max) Off-Leakage Currents at +85°C
- Overvoltage/Undervoltage Clamping Through Protection Diodes
- 500μA (typ) Supply Current
- TSSOP 16-Pin Package
- -40°C to +85°C Ambient Temperature Range
- Functionally Compatible to DG411, DG412, and DG413
- Functionally Operational Up to +125°C

Ordering Information

PART	FUNCTION	TEMP RANGE	PIN-PACKAGE
MAX14756EUE+	Quad NC SPST	-40°C to +85°C	16 TSSOP
MAX14757EUE+	Quad NO SPST	-40°C to +85°C	16 TSSOP
MAX14758EUE+	Dual NO + NC SPST	-40°C to +85°C	16 TSSOP

+Denotes a lead(Pb)-free/RoHS-compliant package.

Functional Diagrams

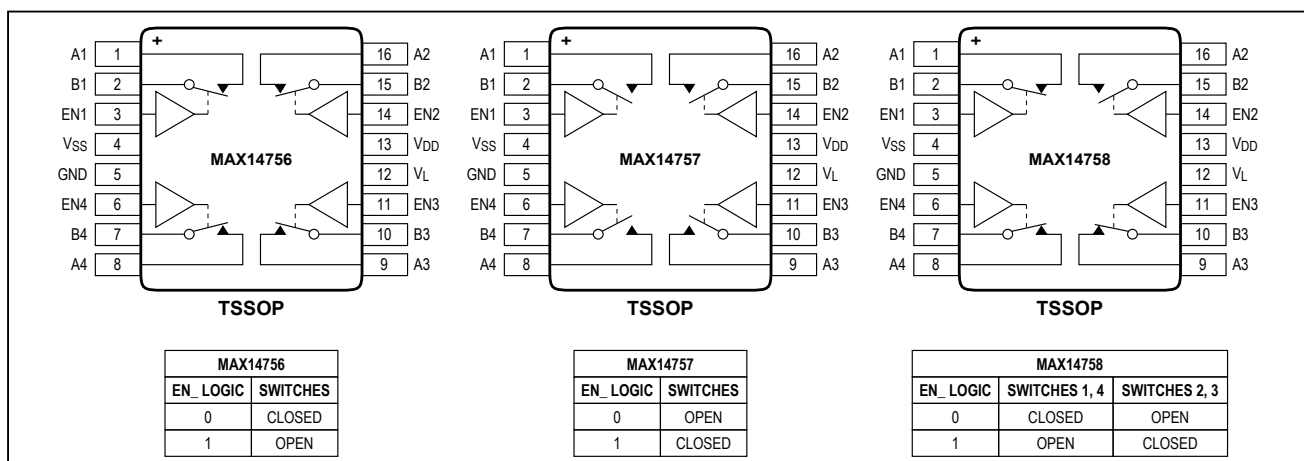

MAX14756/MAX14757/ MAX14758

Quad SPST +70V Analog Switches

Absolute Maximum Ratings

V_{DD} to V_{SS}	-0.3V to +72V
V_{SS} to GND.....	-36V to +0.3V
V_L , EN_ to GND.....	-0.3V to the lesser of (+12V, V_{DD} + 0.3V)
A_+ , B_+ to V_{SS}	-0.3V to (V_{DD} + 2V) or 100mA (whichever occurs first)
Continuous Current into A_+ , B_+	± 100 mA

Continuous Power Dissipation ($T_A = +70^\circ\text{C}$)	
TSSOP (derate 11.1mW/ $^\circ\text{C}$ above $+70^\circ\text{C}$)	889mW
Operating Temperature Range.....	-40°C to $+85^\circ\text{C}$
Storage Temperature Range.....	-65°C to $+150^\circ\text{C}$
Junction Temperature.....	$+150^\circ\text{C}$
Lead Temperature (soldering, 10s).....	$+300^\circ\text{C}$
Soldering Temperature (reflow).....	$+260^\circ\text{C}$

Package Thermal Characteristics (Note 1)

TSSOP	
Junction-to-Ambient Thermal Resistance (θ_{JA}).....	$90^\circ\text{C}/\text{W}$
Junction-to-Case Thermal Resistance (θ_{JC}).....	$27^\circ\text{C}/\text{W}$

Note 1: Package thermal resistances were obtained using the method described in JEDEC specification JESD51-7, using a four-layer board. For detailed information on package thermal considerations, refer to www.maximintegrated.com/thermal-tutorial.

Stresses beyond those listed under "Absolute Maximum Ratings" may cause permanent damage to the device. These are stress ratings only, and functional operation of the device at these or any other conditions beyond those indicated in the operational sections of the specifications is not implied. Exposure to absolute maximum rating conditions for extended periods may affect device reliability.

Electrical Characteristics—Dual Supplies

($V_{DD} = +35\text{V}$, $V_{SS} = -35\text{V}$, $V_{GND} = 0\text{V}$, $V_L = +3.3\text{V}$, $T_A = -40^\circ\text{C}$ to $+85^\circ\text{C}$, unless otherwise noted. Typical values are at $T_A = +25^\circ\text{C}$.)

PARAMETER	SYMBOL	CONDITIONS	MIN	TYP	MAX	UNITS
POWER SUPPLY						
V_{DD} Supply-Voltage Range	V_{DD}		+10		+35	V
V_{SS} Supply-Voltage Range	V_{SS}		-10		-35	V
V_L Logic Supply-Voltage Range	V_L		+1.6		+11	V
V_{DD} Supply Current	$I_{DD(OFF)}$	V_{EN} to switch off state, $V_A, V_B = +20\text{V}$		200	450	μA
	$I_{DD(ON)}$	V_{EN} to switch on state, $V_A, V_B = +20\text{V}$		500	800	
V_{SS} Supply Current	$I_{SS(OFF)}$	V_{EN} to switch off state, $V_A, V_B = +20\text{V}$		200	450	μA
	$I_{SS(ON)}$	V_{EN} to switch on state, $V_A, V_B = +20\text{V}$		500	800	
V_L Current	I_L	$V_L = +11\text{V}$, $V_{EN1} = V_{EN2} = V_{EN3} = V_{EN4} = (0.25 \times V_L)$ or $(0.75 \times V_L)$			0.4	mA
SWITCH						
Analogue-Signal Range	V_A, V_B	Figure 1	V_{SS}		V_{DD}	V
Current Through Switch	I_A, I_B	$V_A, V_B = +20\text{V}$	-50		+50	mA
On-Resistance	R_{ON}	$I_A, I_B = 10\text{mA}$, $V_A, V_B = \pm 20\text{V}$, Figure 1		5	10	Ω
On-Resistance Matching Between Channels	ΔR_{ON}	$I_A, I_B = 10\text{mA}$, $V_A, V_B = \pm 20\text{V}$, 0V (Note 2)		0.3	0.5	Ω
On-Resistance Flatness	$R_{FLAT(ON)}$	$I_A, I_B = 10\text{mA}$, $V_A, V_B = \pm 20\text{V}$		0.004		Ω
On-Leakage Current	$I_{A/B(ON)}$	$V_B = \pm 20\text{V}$, $V_A = \text{unconnected}$, Figure 2	-5		+5	nA
		$V_B = \pm 20\text{V}$, $V_A = \text{unconnected}$, $T_A = +25^\circ\text{C}$, Figure 2		0.01		
Off-Leakage Current	$I_{A/B(OFF)}$	$V_B = \pm 20\text{V}$, $V_A = -20\text{V}$, Figure 3	-2.5		+2.5	nA
		$V_B = \pm 20\text{V}$, $V_A = -20\text{V}$, $T_A = +25^\circ\text{C}$, Figure 3		0.01		

MAX14756/MAX14757/ MAX14758

Quad SPST +70V Analog Switches

Electrical Characteristics—Dual Supplies (continued)

($V_{DD} = +35V$, $V_{SS} = -35V$, $V_{GND} = 0V$, $V_L = +3.3V$, $T_A = -40^{\circ}C$ to $+85^{\circ}C$, unless otherwise noted. Typical values are at $T_A = +25^{\circ}C$.)

PARAMETER	SYMBOL	CONDITIONS	MIN	TYP	MAX	UNITS
LOGIC (EN1, EN2, EN3, EN4)						
Input-Voltage Low	V_{IL}				$0.25 \times V_L$	V
Input-Voltage High	V_{IH}		$0.75 \times V_L$			V
Input Leakage Current		$V_{EN} = 0V$ or V_L	-1		+1	μA
DYNAMIC CHARACTERISTICS						
V_{DD}/V_{SS} Power-On Time		$R_L = 10k\Omega$		1		μs
Enable Turn-On Time	t_{ON}	$V_A, V_B = \pm 10V$, $R_L = 10k\Omega$, Figure 4		35	60	μs
Enable Turn-Off Time	t_{OFF}	$V_A, V_B = \pm 10V$, $R_L = 10k\Omega$, Figure 4		2	3	μs
Off-Isolation	V_{ISO}	$V_A, V_B = 1V$ RMS, $f = 100kHz$, $R_L = 1k\Omega$, $C_L = 15pF$, Figure 5		65		dB
Crosstalk	V_{CT}	$R_S = R_L = 1k\Omega$, Figure 6		96		dB
-3dB Bandwidth	BW	$R_S = 50\Omega$, $R_L = 1k\Omega$, Figure 7		145		MHz
Total Harmonic Distortion Plus Noise	THD+N	$R_S = R_L = 1k\Omega$, $f = 20Hz$ to $20kHz$		0.001		%
Charge Injection	Q	$A_-, B_- = GND$, $C_L = 1nF$, Figure 8		580		pC
Switch-On Capacitance	C_{IN}	$V_{DD} = +50V$, $V_{SS} = 0V$, $V_A, V_B = +4V$, $f = 1MHz$		40		pF
Switch-Off Capacitance	C_{IN}	$V_{DD} = +50V$, $V_{SS} = 0V$, $V_A, V_B = +4V$, $f = 1MHz$		35		pF

DC Electrical Characteristics—Single Supply

($V_{DD} = +70V$, $V_{SS} = V_{GND} = 0V$, $V_L = +3.3V$, $T_A = -40^{\circ}C$ to $+85^{\circ}C$, unless otherwise noted. Typical values are at $T_A = +25^{\circ}C$.) (Note 2)

PARAMETER	SYMBOL	CONDITIONS	MIN	TYP	MAX	UNITS
POWER SUPPLY						
V_{DD} Supply-Voltage Range	V_{DD}		+10		+70	V
SWITCH						
On-Resistance	R_{ON}	$I_{A_-} = 10mA$, $V_A, V_B = +20V$, Figure 1		5	10	Ω
On-Resistance Matching Between Channels	DR_{ON}	$I_{A_-}, I_{B_-} = 10mA$, $V_A, V_B = +70V, 0V$ (Note 2)		0.3	0.5	Ω
Off-Leakage Current	I_{A/B_OFF}	$V_B = +40V$, $V_A = +10V$, Figure 3	-2.5		+2.5	nA

Note 2: Guaranteed by design; not production tested.

Note 3: All parameters in single-supply operation are expected to be the same as in dual-supply operation.

**MAX14756/MAX14757/
MAX14758**

Quad SPST +70V Analog Switches

Test Circuits/Timing Diagrams

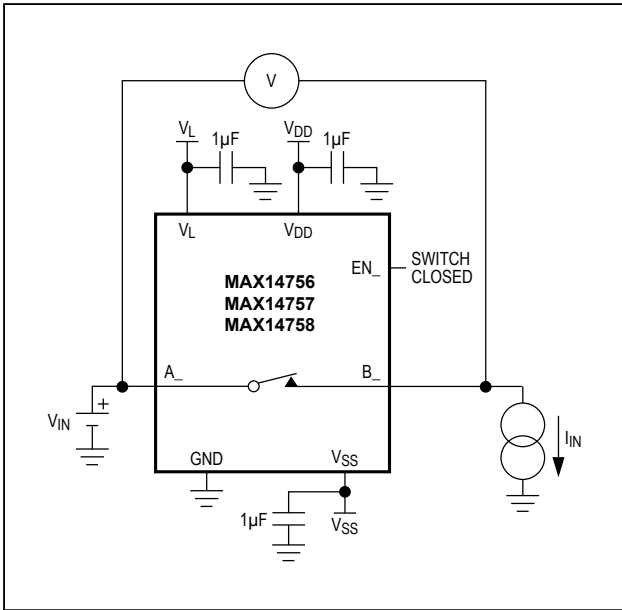

Figure 1. On-Resistance Measurement

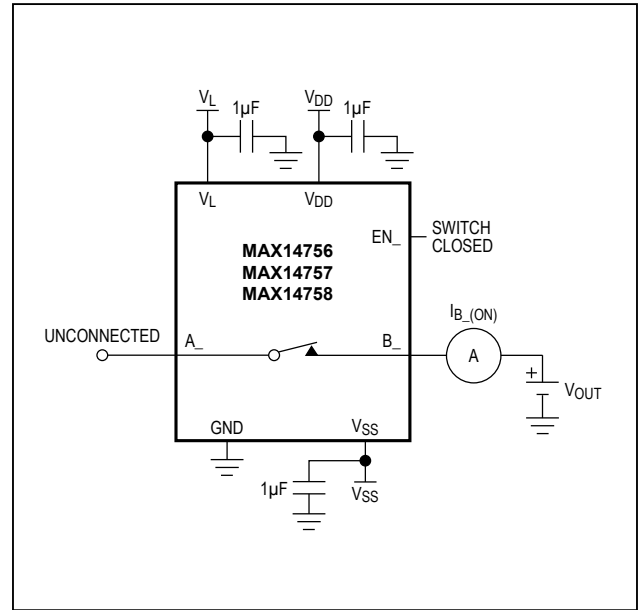

Figure 2. On-Leakage Current

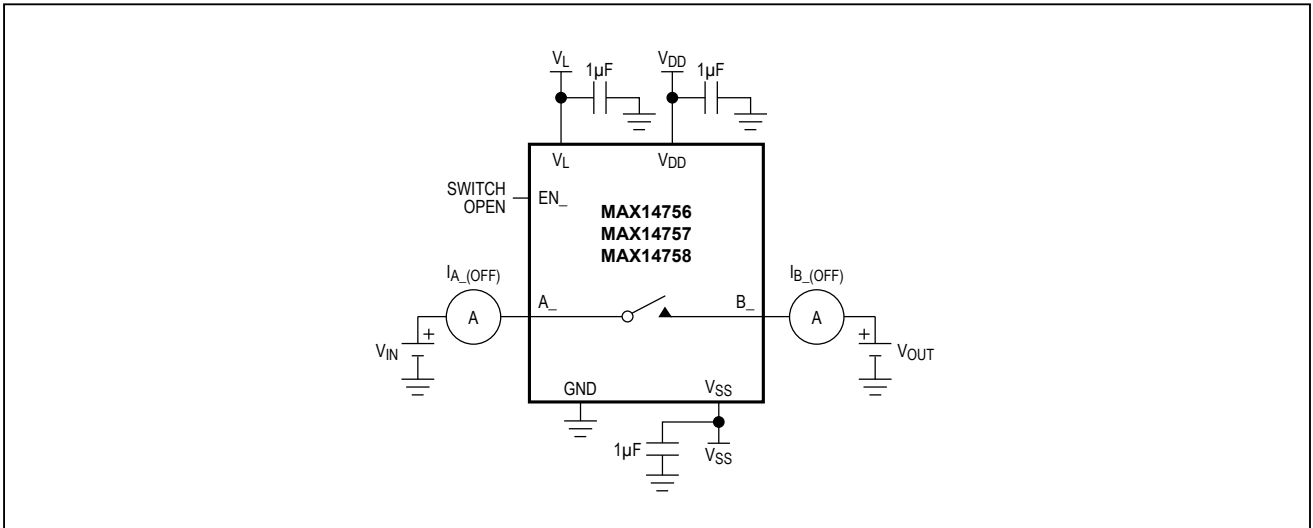

Figure 3. Off-Leakage Current

**MAX14756/MAX14757/
MAX14758**

Quad SPST +70V Analog Switches

Test Circuits/Timing Diagrams (continued)

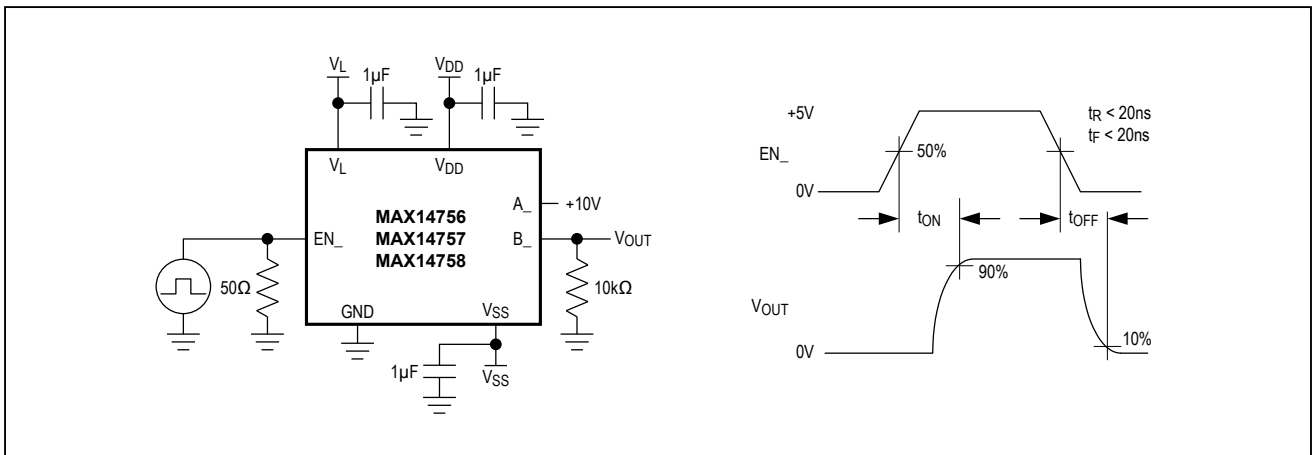

Figure 4. Enable Switching Time

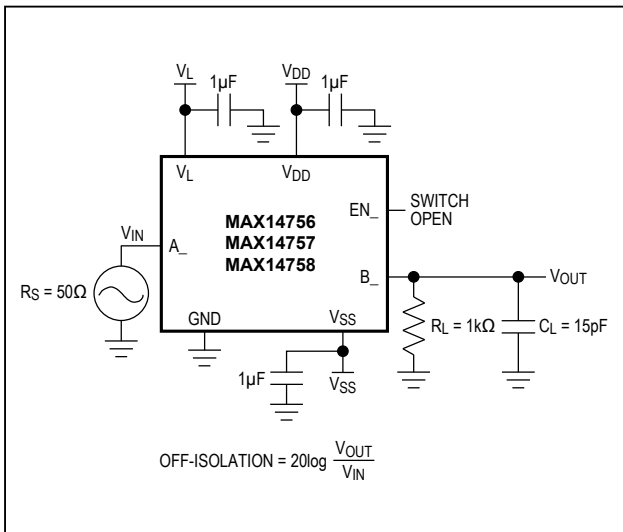

Figure 5. Off-Isolation

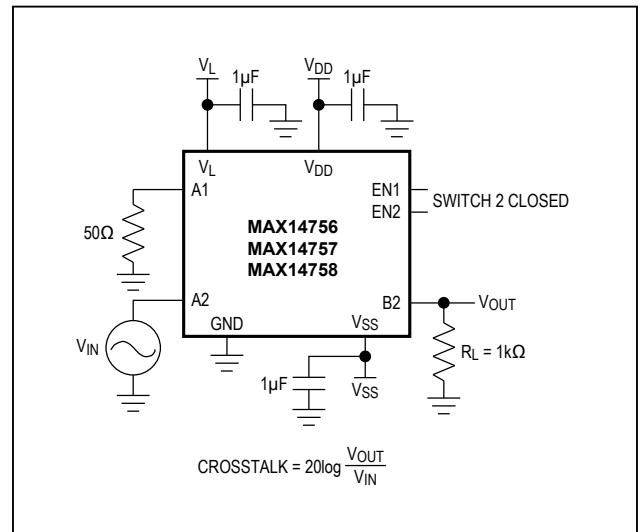

Figure 6. Crosstalk

**MAX14756/MAX14757/
MAX14758**

Quad SPST +70V Analog Switches

Test Circuits/Timing Diagrams (continued)

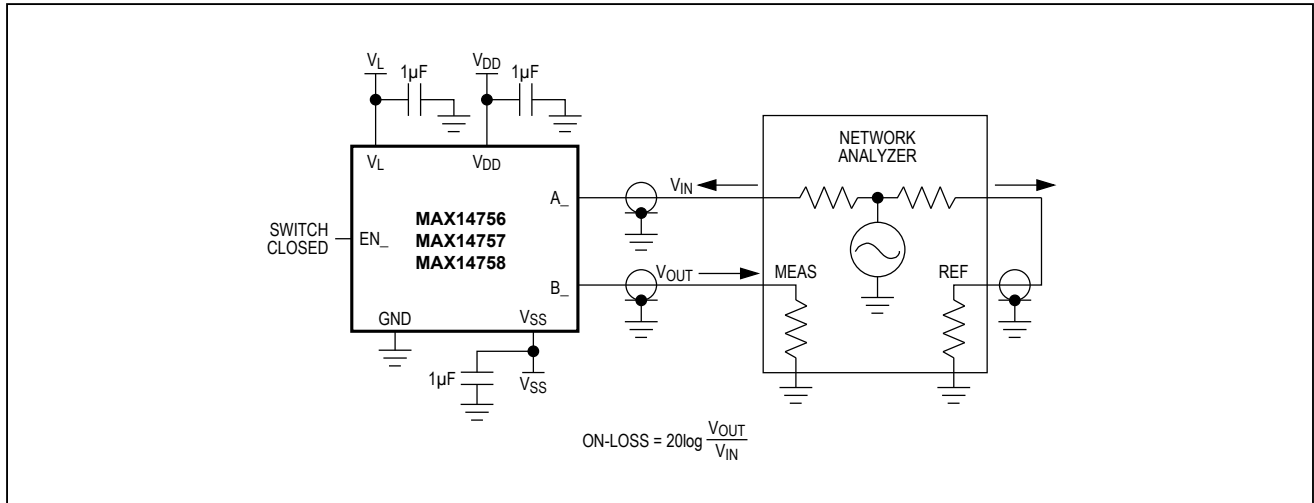

Figure 7. Frequency Response

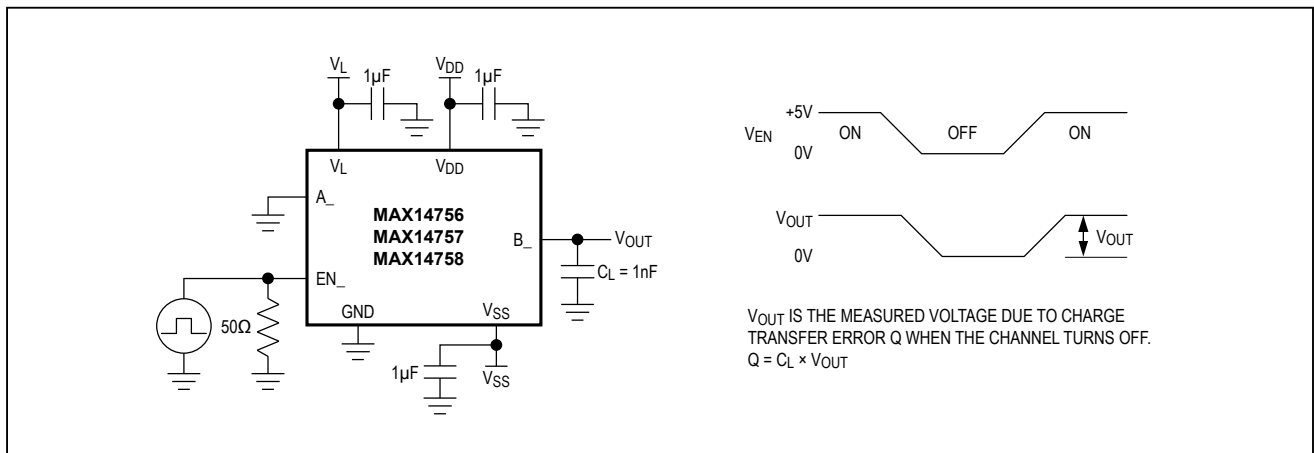

Figure 8. Charge Injection

**MAX14756/MAX14757/
MAX14758**

Quad SPST +70V Analog Switches

Typical Operating Characteristics

($T_A = +25^\circ\text{C}$, $V_L = +3.3\text{V}$, unless otherwise noted.)

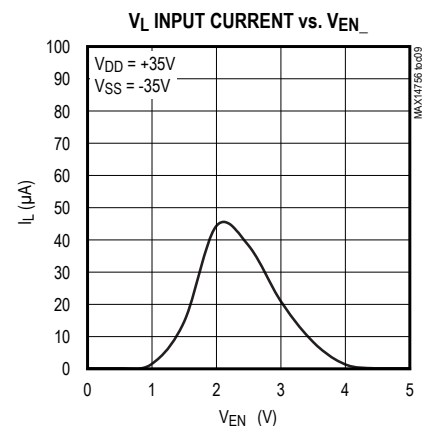
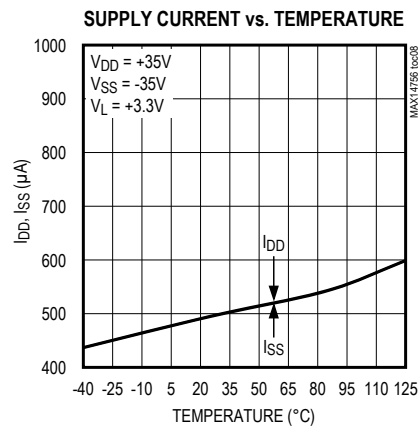
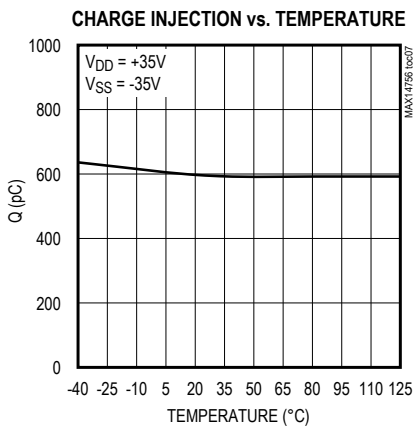
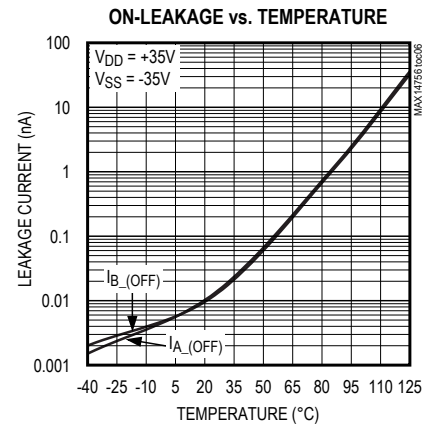
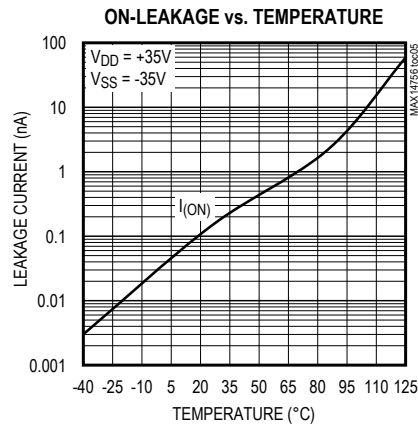
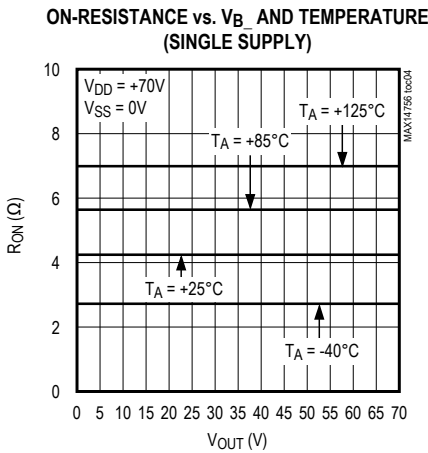
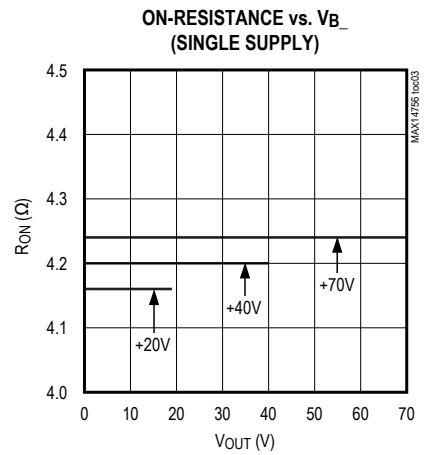
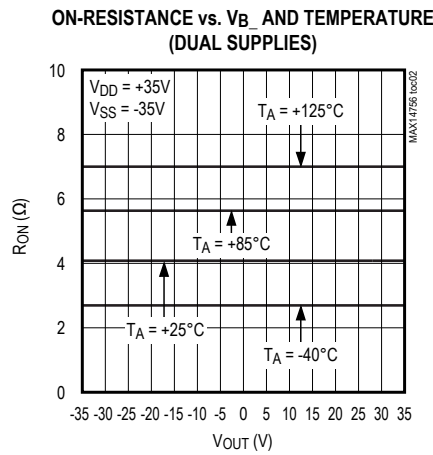
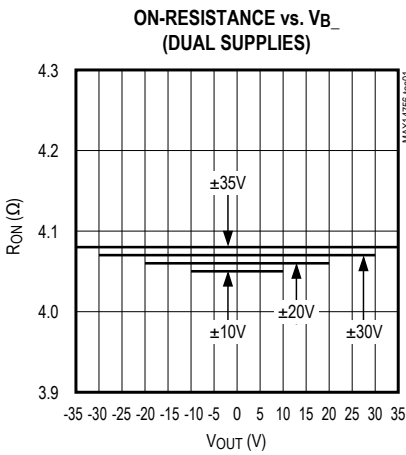

**MAX14756/MAX14757/
MAX14758**

Quad SPST +70V Analog Switches

Typical Operating Characteristics (continued)

($T_A = +25^\circ\text{C}$, $V_L = +3.3\text{V}$, unless otherwise noted.)

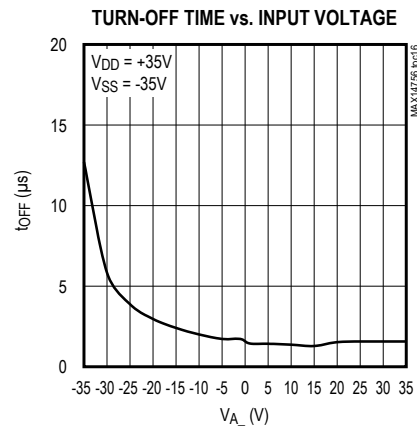
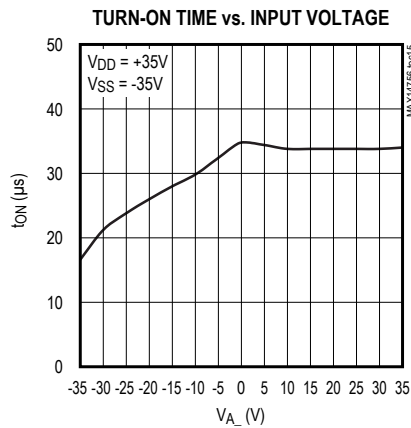
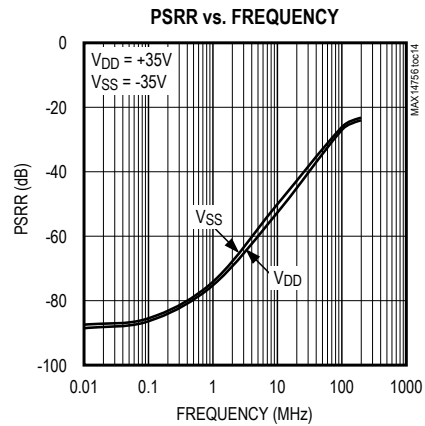
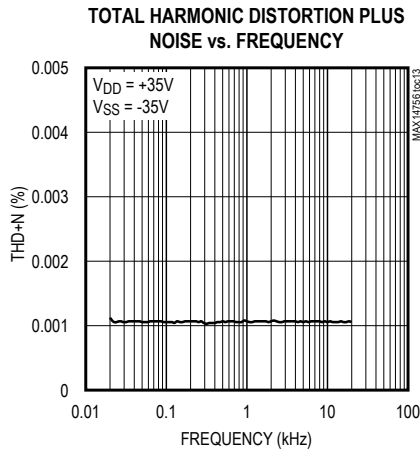
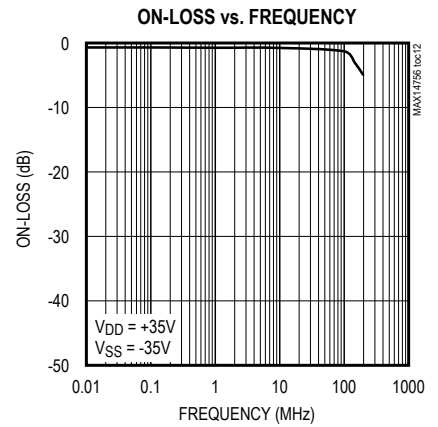
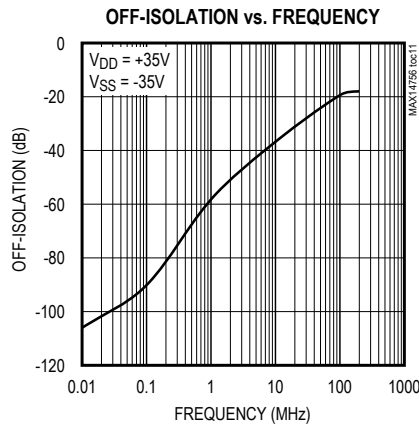
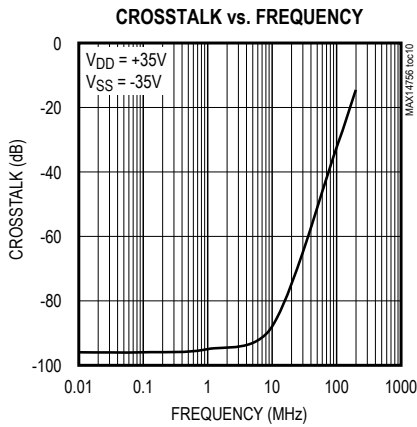

MAX14756/MAX14757/ MAX14758

Quad SPST +70V Analog Switches

Pin Configuration

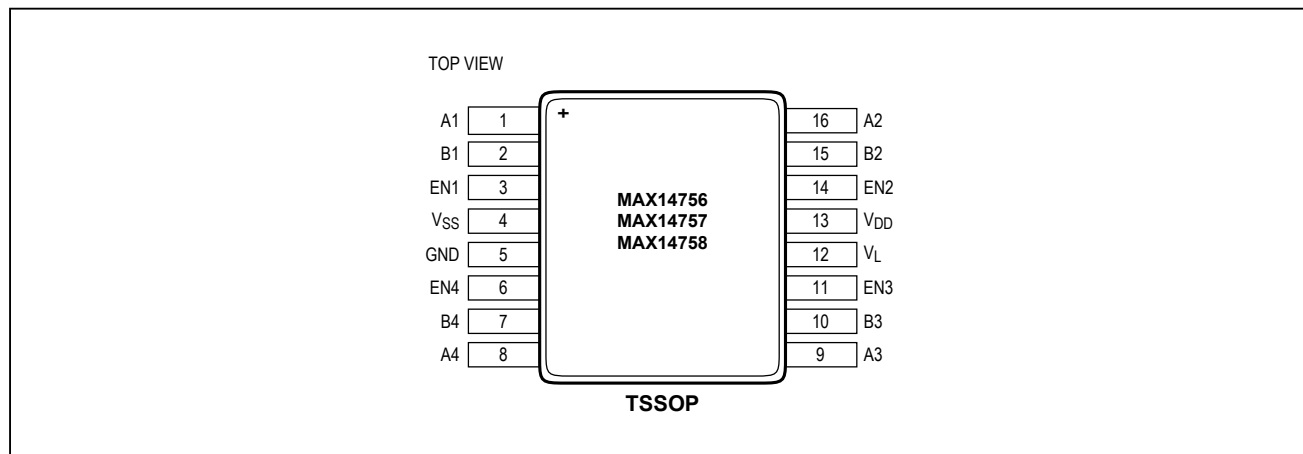

Pin Description

PIN	NAME	FUNCTION
1	A1	Terminal A of Switch 1
2	B1	Terminal B of Switch 1
3	EN1	Enable Input of Switch 1. When EN1 is driven high, the switch's state (NO/NC) changes (see Table 1 , Table 2 , and Table 3).
4	V _{SS}	Negative Supply Voltage. Bypass V _{SS} to GND with a 1μF ceramic capacitor (100V rated) as close as possible to the pin.
5	GND	Ground
6	EN4	Enable Input of Switch 4. When EN4 is driven high, the switch's state (NO/NC) changes (see Table 1 , Table 2 , and Table 3).
7	B4	Terminal B of Switch 4
8	A4	Terminal A of Switch 4
9	A3	Terminal A of Switch 3
10	B3	Terminal B of Switch 3
11	EN3	Enable Input of Switch 3. When EN3 is driven high, the switch's state (NO/NC) changes (see Table 1 , Table 2 , and Table 3).
12	V _L	Logic Supply Voltage. Bypass V _L to GND with a 1μF ceramic capacitor as close as possible to the pin.
13	V _{DD}	Positive Supply Voltage. Bypass V _{DD} to GND with a 1μF ceramic capacitor (100V rated) as close as possible to the pin.
14	EN2	Enable Input of Switch 2. When EN2 is driven high, the switch's state (NO/NC) changes (see Table 1 , Table 2 , and Table 3).
15	B2	Terminal B of Switch 2
16	A2	Terminal A of Switch 2

MAX14756/MAX14757/ MAX14758

Quad SPST +70V Analog Switches

Detailed Description

The MAX14756/MAX14757/MAX14758 are analog switches with low on-resistance of 10Ω (max) that conduct equally well in both directions. All devices have a rail-to-rail analog-signal range. They operate with a single +70V supply in unipolar applications or ±35V dual supplies in bipolar applications. The bipolar supplies can be offset and do not have to be symmetrical.

The MAX14756 is a quad NC SPST switch, the MAX14757 is a quad NO SPST switch, and the MAX14758 has two NO and two NC SPST switches. These switches have 5Ω (typ) on-resistances and low on-leakage currents of 5nA (max). The on-resistance flatness is 0.004Ω (typ). These devices are suitable for a multitude of analog-signal routing and switching applications, and are functionally operational up to +125°C with increased leakage currents.

Applications Information

Low-Distortion Audio

The MAX14756/MAX14757/MAX14758 switches, having low R_{ON} and very low R_{ON} variation with signal amplitude, are well suited for low-distortion audio applications. The *Typical Operating Characteristics* section shows Total Harmonic Distortion (THD) vs. Frequency graphs for several signal amplitudes.

Current Through the Switches

The current flowing through every switch must be limited to ±50mA for normal operation. If the current exceeds this limit, an internal leakage current flows from the switch to V_{SS} . Larger input currents do not destroy the device, as long as the *Absolute Maximum Ratings* are not exceeded.

Input-Voltage Clamping

For applications that require input voltages beyond the supplies rails, the internal input diodes to V_{DD} and V_{SS} can be used to limit the input voltages. As shown in Figure 9, series resistors can be employed at the inputs to limit the currents flowing into the diodes during undervoltage and overvoltage conditions. Choose the limiting resistors such that the input currents are limited to $I_{IN_}(MAX) = 100mA$. The values of the current-limit resistors can be calculated as the larger of R_{LIM+} and R_{LIM-} .

$$R_{LIM+} = \frac{V_{IN(MAX)} - V_{DD}}{I_{IN_}(MAX)}$$

$$R_{LIM-} = \frac{V_{SS} - V_{IN(MIN)}}{I_{IN_}(MAX)}$$

Table 1. MAX14756 Truth Table

LOGIC		SWITCH	
EN1	0	A1/B1	Closed
EN2	0	A2/B2	Closed
EN3	0	A3/B3	Closed
EN4	0	A4/B4	Closed
EN1	1	A1/B1	Open
EN2	1	A2/B2	Open
EN3	1	A3/B3	Open
EN4	1	A4/B4	Open

Table 2. MAX14757 Truth Table

LOGIC		SWITCH	
EN1	0	A1/B1	Open
EN2	0	A2/B2	Open
EN3	0	A3/B3	Open
EN4	0	A4/B4	Open
EN1	1	A1/B1	Closed
EN2	1	A2/B2	Closed
EN3	1	A3/B3	Closed
EN4	1	A4/B4	Closed

Table 3. MAX14758 Truth Table

LOGIC		SWITCH	
EN1	0	A1/B1	Closed
EN2	0	A2/B2	Open
EN3	0	A3/B3	Open
EN4	0	A4/B4	Closed
EN1	1	A1/B1	Open
EN2	1	A2/B2	Closed
EN3	1	A3/B3	Closed
EN4	1	A4/B4	Open

During an undervoltage or overvoltage condition, the input impedance is equal to R_{LIM} . The additional power dissipation due to the fault currents needs to be calculated. During an overvoltage or undervoltage clamping condition on one switch input, the other switches of the MAX14756/MAX14757/MAX14758 operate normally.

Beyond-the-Rail Input

If input voltages are expected to go beyond the supply voltages, but within the absolute maximum supply voltages of the MAX14756/MAX14757/MAX14758, add two diodes in series with the supplies as shown in [Figure 10](#).

**MAX14756/MAX14757/
MAX14758**

Quad SPST +70V Analog Switches

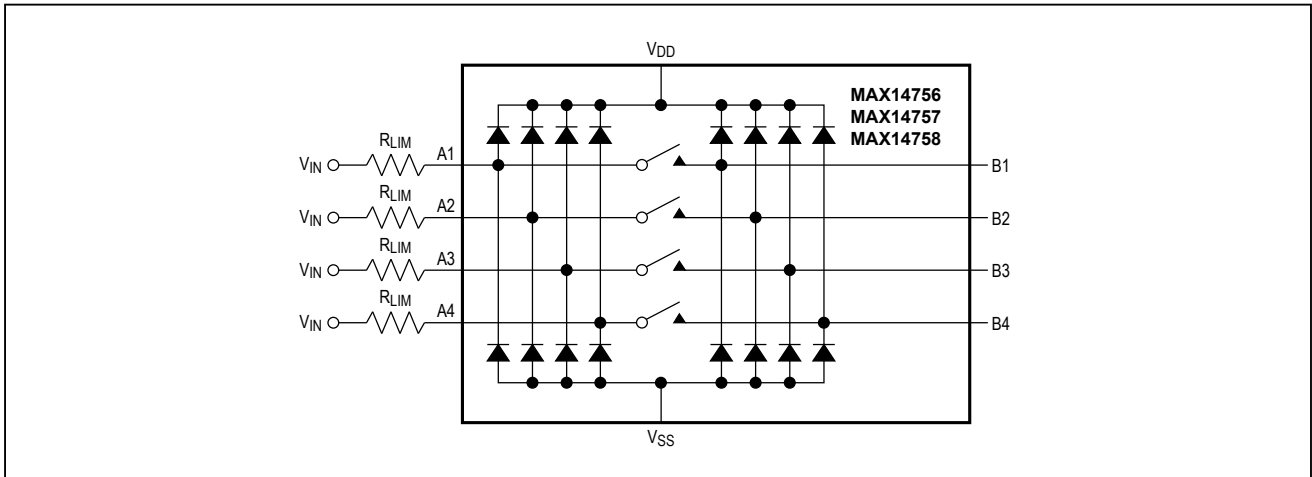

Figure 9. Input Overvoltage and Undervoltage Clamping

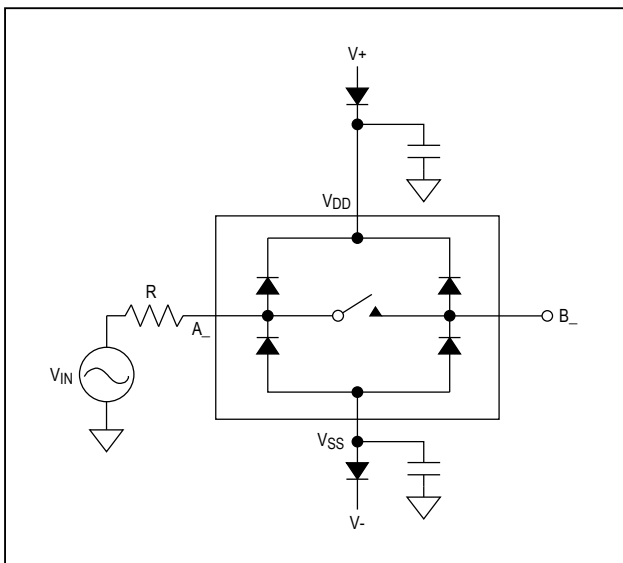

Figure 10. Beyond-the-Rail Application

During undervoltage and overvoltage events, the internal diodes pull V_{DD}/V_{SS} supplies up/down. An advantage of this scheme is that the input impedance is high and currents do not flow through the MAX14756/MAX14757/MAX14758 during overvoltage and undervoltage events. The input voltages must be limited to the voltages specified in the *Absolute Maximum Ratings* section.

Chip Information

PROCESS: BiCMOS

Package Information

For the latest package outline information and land patterns (footprints), go to www.maximintegrated.com/packages. Note that a "+", "#", or "-" in the package code indicates RoHS status only. Package drawings may show a different suffix character, but the drawing pertains to the package regardless of RoHS status.

PACKAGE TYPE	PACKAGE CODE	OUTLINE NO.	LAND PATTERN NO.
16 TSSOP	U16+1	21-0066	90-0117

MAX14756/MAX14757/
 MAX14758

Quad SPST +70V Analog Switches

Revision History

REVISION NUMBER	REVISION DATE	DESCRIPTION	PAGES CHANGED
0	12/10	Initial release	—
1	11/14	Removed automotive reference in <i>Applications</i> section	1

For pricing, delivery, and ordering information, please contact Maxim Direct at 1-888-629-4642, or visit Maxim Integrated's website at www.maximintegrated.com.

Maxim Integrated cannot assume responsibility for use of any circuitry other than circuitry entirely embodied in a Maxim Integrated product. No circuit patent licenses are implied. Maxim Integrated reserves the right to change the circuitry and specifications without notice at any time. The parametric values (min and max limits) shown in the Electrical Characteristics table are guaranteed. Other parametric values quoted in this data sheet are provided for guidance.