

## Excellent Integrated System Limited

Stocking Distributor

Click to view price, real time Inventory, Delivery & Lifecycle Information:

[Twin Industries](#)  
[MB-16](#)

For any questions, you can email us directly:  
[sales@integrated-circuit.com](mailto:sales@integrated-circuit.com)

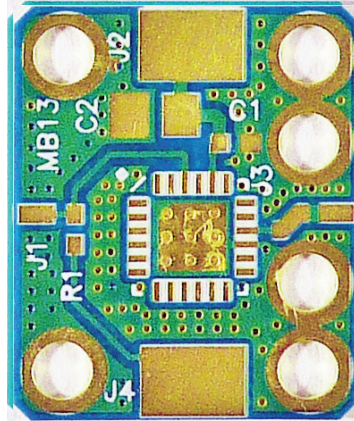

**FEATURES**

- Fits Hittite Microwave tunable filters with LP4E packages
- Usable with HMC895-898 tunable bandpass filters
- Uses standard SMD passive parts
- RO-4350 board material
- Fits MicroAmp MH-series housings

The MicroAmp MB-16 circuit board is designed for rapid prototyping of tunable bandpass filters using Hittite Microwave devices in LP4E packages with RF inputs on pin 3, RF outputs on pin 16, and control connections on pins 8-10. Filter MMICs are available at various frequencies throughout the 6.8 to 21 GHz range. This board will fit the MicroAmp MH series of connectorized housings that allow it to be used as a stand-alone multiplier or cascaded with other MicroAmp boards for added versatility. Boards are fabricated from a high-performance 13 mil thick RO-4350 laminate with RoHS compatible ENIG plating (electroless nickel/immersion gold) on both the component side and the solid bottom ground plane. The board measures 0.490" x 0.590" and mounts into the housing with four or eight #1-72 screws for optimal high frequency grounding. Filter circuits can be easily assembled with standard surface-mount passive components. The MB-16 includes provisions for control bias bypassing. Pads for the input/output RF connectors allow the SMA center pins to be easily soldered to the board after it is installed into the housing, as well as large pads to connect the control voltages to feed-throughs. Check the specific data sheet for the filter being used. Many of the pins are unused and need not be soldered to the ground plane.

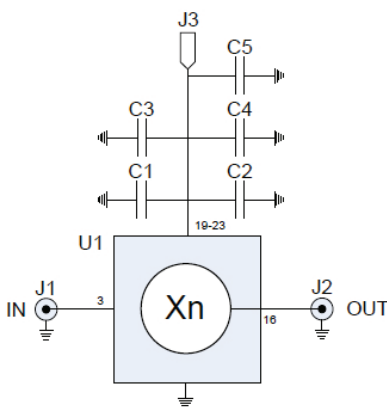

TUNABLE FILTER SCHEMATIC

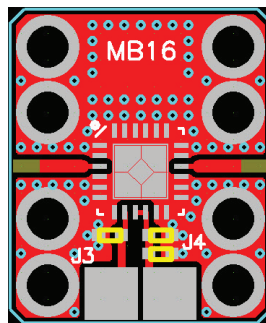

ASSEMBLY

**REF SIZE FUNCTION**

C1	0402	Bias bypass (not labeled)
C2	0402	Bias bypass (not labeled)
C3	0402	Bias bypass (not labeled)
U1	LP4E	Tunable Filter
J1		RF input (pin 3)
J2		RF output (pin 16)
J3		Control bias (pin 8)
J4		Control bias (pins 9,10)