

Excellent Integrated System Limited

Stocking Distributor

Click to view price, real time Inventory, Delivery & Lifecycle Information:

[Maxim Integrated](#)
[MAX19000EVKIT+](#)

For any questions, you can email us directly:

sales@integrated-circuit.com



MAX19000 Evaluation Kit

General Description

The MAX19000 evaluation kit (EV kit) is a fully assembled and tested PCB that evaluates the MAX19000 dual-channel, high-performance pin electronics driver/comparator/load (DCL) with built-in level-setters. The EV kit includes SMA connections for the high-speed digital I/Os and the MAX19000 pin-driver outputs. The MAX19000 EV kit is connected to the PC through the universal serial bus (USB) port. The EV kit also includes Windows® 2000-, Windows XP®, and Windows Vista®-compatible software that provides a simple graphical user interface (GUI) for exercising the features of the MAX19000.

Features

- ◆ Internal Level-Setting DACs
- ◆ Heat Sink Included for Safe Operation
- ◆ Windows 2000-, Windows XP-, and Windows Vista (32-Bit)-Compatible Software
- ◆ USB-PC Connection (Cable Included)
- ◆ Proven PCB Layout
- ◆ Fully Assembled and Tested

Ordering Information

PART	TYPE
MAX19000EVKIT+	EV Kit

+Denotes lead(Pb)-free and RoHS compliant.

Component List

DESIGNATION	QTY	DESCRIPTION
C1-C12	12	10nF ±10%, 25V X7R ceramic capacitors (0402) Murata GRM155R71E103K
C13	1	10µF ±10%, 25V X5R ceramic capacitor (1206) Murata GRM31CR61E106K
C14, C15, C16, C18, C20, C23, C24, C27	8	0.1µF ±10%, 25V X7R ceramic capacitors (0603) Murata GRM188R71E104K
C17, C19, C21, C22, C25, C26	6	1µF ±10%, 25V X7R ceramic capacitors (0805) Murata GRM21BR71E105K
C43, C54, C56	3	10µF ±20%, 16V X5R ceramic capacitors (1206) Murata GRM31CR61C106M
C44, C45	2	22pF ±5%, 50V C0G ceramic capacitors (0603) Murata GRM1885C1H220J
C46	1	0.033µF ±10%, 16V X5R ceramic capacitor (0603) Taiyo Yuden EMK107BJ333KA
C47-C52, C59, C60	8	0.1µF 10%, 16V X7R ceramic capacitors (0603) TDK C1608X7R1C104K

DESIGNATION	QTY	DESCRIPTION
C53, C55, C61-C68	10	1µF ±10%, 16V X5R ceramic capacitors (0603) Murata GRM188R61C105K
C57, C58	2	10pF ±5%, 50V C0G ceramic capacitors (0603) Murata GRM1885C1H100J
D1	1	Red LED (0603)
J1-J18	18	SMA end-launch jack receptacles
J20, J22, J24	3	Banana jacks, uninsulated (panel jack)
J21	1	24-pin header (2 x 12)
J23	1	USB type-B right-angle PC-mount receptacle
JU1, JU2, JU3, JU15, JU16, JU18-JU23, JU24	12	2-pin headers
JU4-JU11	8	3-pin headers
L1	1	Ferrite bead TDK MMZ1608R301A (0603)
L2, L3	2	10µH ±10%, 340mΩ inductors (1210) Panasonic ELJ-EA100KF

Windows, Windows XP, and Windows Vista are registered trademarks of Microsoft Corp.



MAX19000 Evaluation Kit

Evaluates: MAX19000

Component List (continued)

DESIGNATION	QTY	DESCRIPTION
R1, R2	2	1kΩ ±5% resistors (0603)
R3	1	280Ω ±1% resistor (0603)
R4	1	2.26kΩ ±1% resistor (0603)
R5, R8	2	402Ω ±1% resistors (0603)
R6	1	75Ω ±1% resistor (0603)
R7	1	249Ω ±1% resistor (0603)
R9, R18–R22	0	Not installed, resistors—shorted with PCB trace (0603)
R10, R11	2	27Ω ±5% resistors (0603)
R12	1	1.5kΩ ±5% resistor (0603)
R13	1	470Ω ±5% resistor (0603)
R14	1	2.2kΩ ±5% resistor (0603)
R15	1	10kΩ ±5% resistor (0603)
R16	1	169kΩ ±1% resistor (0603)
R17	1	100kΩ ±1% resistor (0603)
R23	1	200Ω SMT cermet trimmer, 9 to 15 turns
R24	1	220Ω ±5% resistor (0603)
R26–R29	4	243Ω ±1% resistors (0603)
R32	1	1.5kΩ ±1% resistor (0603)
TMPSNS, TP1, TP2, TP3, TP12, TP14–TP17	9	Miniature test points, black
U1	1	Dual din driver (64 TQFP-EP*) Maxim MAX19000BECB+
U2	1	2.5V voltage reference Maxim MAX6126AASA25+

DESIGNATION	QTY	DESCRIPTION
U3	1	LDO regulator (5 SC70) Maxim MAX8511EXK25+T
U4	1	USB-to-UART converter (32 TQFP)
U5	1	93C46 type 3-wire EEPROM (8 SO)
U6	1	Microcontroller (68 QFN-EP*) Maxim MAXQ2000-RAX+
U7	1	Adjustable output LDO regulator (5 SC70) Maxim MAX8512EXK+T
U8–U11	4	Level translators (10 μMAX®) Maxim MAX1840EUB+
U14–U17	4	LDOs (3 TO263)
Y1	1	16MHz crystal Hong Kong X'tals SSM16000N1HK188F0-0
Y2	1	6MHz crystal Hong Kong X'tals SSL60000N1HK188F0-0
Y3	0	Not installed
—	1	Heatpad
—	1	Heat sink
—	20	Shunts
—	1	PCB: MAX19000 EVALUATION KIT+

*EP = Exposed pad.

Component Suppliers

SUPPLIER	PHONE	WEBSITE
Hong Kong X'tals Ltd.	852-35112388	www.hongkongcrystal.com
Murata Electronics North America, Inc.	770-436-1300	www.murata-northamerica.com
Panasonic Corp.	800-344-2112	www.panasonic.com
Taiyo Yuden	800-348-2496	www.t-yuden.com
TDK Corp.	847-803-6100	www.component.tdk.com

Note: Indicate that you are using the MAX19000 when contacting these component suppliers.

μMAX is a registered trademark of Maxim Integrated Products, Inc.

MAX19000 Evaluation Kit

Evaluates: MAX19000

MAX19000 EV Kit Files

FILE	DESCRIPTION
INSTALL.EXE	Installs the EV kit files on your computer
MAX19000.EXE	Application program
FTD2XX.INF	USB device driver file
UNINST.INI	Uninstalls the EV kit software
USB_Driver_Help.PDF	USB driver installation help file

Quick Start

Required Equipment

- MAX19000 EV kit (USB cable included)
- User-supplied Windows 2000, Windows XP, or Windows Vista PC with a spare USB port
- +15V/0.5A DC power supply (VHH)
- -5.25V/0.5A DC power supply (VEE)
- LVDS source (RCV0/NRCV0)
- Differential output pulse generator
- High-speed oscilloscope
- Digital voltmeter (DVM)

Note: In the following sections, software-related items are identified by bolding. Text in **bold** refers to items directly from the EV kit software. Text in **bold and underlined** refers to items from the Windows operating system.

Procedure

The MAX19000 EV kit is fully assembled and tested. Follow the steps below to verify board operation.

Caution: Do not turn on the power supply until all connections are completed.

- 1) Visit www.maxim-ic.com/evkitsoftware to download the latest version of the EV kit software, 19000Rx.ZIP. Save the EV kit software to a temporary folder and uncompress the ZIP file.
- 2) Install the EV kit software on your computer by running the INSTALL.EXE program inside the temporary folder. The program files are copied and icons are created in the Windows **Start | Programs** menu.
- 3) Make sure the shunts of all jumpers are in the default positions, as shown in Tables 1 and 2.
- 4) Verify that the heat sink is installed and flush on the top of the MAX19000 IC.
- 5) Verify the correct polarity, voltage, and current limit of all power supplies.
- 6) Set the differential pulse generator to output $\pm 200\text{mV}$ centered at +1.2V common-mode voltage. Ensure the outputs are disabled (high impedance). Set the pulse frequency to 20MHz, 50% duty cycle.
- 7) Connect the +15V power supply between the J20 (VHH) and J22 (GND) banana jacks on the MAX19000 EV kit.
- 8) Connect the -5.25V power supply between the J22 (GND) and J24 (VEE) banana jacks on the MAX19000 EV kit. Connect all power-supply grounds to a single ground terminal.
- 9) Connect the positive input of the DVM to TMPSNS and the negative input to ground.
- 10) Connect the differential pulse generator to the DATA0 and NDATA0 SMA connectors on the MAX19000 EV kit with SMA cables of equal length.
- 11) Set the RCV0/NRCV0 to a differential logic-low with $V_{RCV0} = +1\text{V}$ and $V_{NRCV0} = +1.4\text{V}$ to disable the three-state output mode.
- 12) Connect the DUT0 SMA connector on the MAX19000 EV kit with a short SMA cable to the high-speed oscilloscope. Set the scope input impedance to 50Ω .
- 13) Turn on the power supplies in the following order, VHH, VEE. By default, the MAX19000 starts in low-leakage mode.
- 14) Enable the differential pulse generator.
- 15) Connect the USB cable from the PC to the EV kit board. A **New Hardware Found** window pops up when installing the USB driver for the first time. If a window is not seen that is similar to the one described above after 30s, remove the USB cable from the board and reconnect it. Administrator privileges are required to install the USB device driver on Windows.
- 16) Follow the directions of the **Found New Hardware** window to install the USB device driver. Manually specify the location of the device driver to be **C:\Program Files\MAX19000** (default installation directory) using the **Browse** button. During device driver installation, Windows may show a warning message indicating that the device driver Maxim uses does not contain a digital signature. This is not an error condition and it is safe to proceed with installation. Refer to the USB_Driver_Help.PDF document included with the software for additional information.

MAX19000 Evaluation Kit

Evaluates: MAX19000

- 17) Start the MAX19000 EV kit software by opening its icon in the **Start | Programs** menu. The EV kit software main window appears, as shown in Figure 1. The MAX19000 EV kit software places the MAX19000 in drive mode.
- 18) Select the **DCL/Channel 0** tab.
- 19) Set VCH to 6.2V by entering **6.2** into the **VCH** edit box located inside the **Voltage** group box and press the Enter key on the keyboard.
- 20) Set VCL to -2.2V by entering **-2.2** into the **VCL** edit box located inside the **Voltage** group box and press the Enter key on the keyboard.
- 21) Set VDH to 1V by entering **1** into the **VDH** edit box located inside the **Voltage** group box and press the Enter key on the keyboard.
- 22) Set VDL to 0V by entering **0** into the **VDL** edit box located inside the **Voltage** group box and press the Enter key on the keyboard.
- 23) This places channel 0 into the drive-high mode.
- 24) Select the **DCL/Channel 1** tab and repeat steps 19–22 to place the channel 1 into the drive-high mode.
- 25) The TMPSNS test point monitors the MAX19000 junction temperature. Verify that the voltmeter does not read higher than +4.2V (junction temperature < +150°C).
- 26) Set the oscilloscope to 10MΩ high-impedance mode.
- 27) Set the oscilloscope to trigger on the OUT0 channel, with the trigger level set to +0.5V. Set the time base to 20ns per division. A 0 to +1V square wave of 20MHz appears on the oscilloscope.

Table 1. Digital Interface Jumper Settings

JUMPER	SHUNT POSITION	DESCRIPTION
JU4	1-2*	Connects the DOUT pin of the MAX19000 to the on-board MAXQ2000 microcontroller through a level translator
	2-3	Connects the external DOUT signal to the J21-1 pin of the J21 connector
JU5	1-2*	Connects the DIN pin of the MAX19000 to the on-board MAXQ2000 microcontroller through a level translator
	2-3	Connects the external DIN signal to the J21-3 pin of the J21 connector
JU6	1-2*	Connects the \overline{CS} pin of the MAX19000 to the on-board MAXQ2000 microcontroller through a level translator
	2-3	Connects the external \overline{CS} signal to the J21-7 pin of the J21 connector
JU7	1-2*	Connects the SCLK pin of the MAX19000 to the on-board MAXQ2000 microcontroller through a level translator
	2-3	Connects the external SCLK signal to the J21-5 pin of the J21 connector
JU8	1-2*	Connects the $\overline{LLEAKP0}$ pin of the MAX19000 to the on-board MAXQ2000 microcontroller through a level translator
	2-3	Connects the external $\overline{LLEAKP0}$ signal to the J21-13 pin of the J21 connector
JU9	1-2*	Connects the $\overline{LLEAKP1}$ pin of the MAX19000 to the on-board MAXQ2000 microcontroller through a level translator
	2-3	Connects the external $\overline{LLEAKP1}$ signal to the J21-15 pin of the J21 connector
JU10	1-2*	Connects the \overline{RST} pin of the MAX19000 to the on-board MAXQ2000 microcontroller through a level translator
	2-3	Connects the external \overline{RST} signal to the J21-11 pin of the J21 connector
JU11	1-2*	Connects the \overline{LOAD} pin of the MAX19000 to the on-board MAXQ2000 microcontroller through a level translator
	2-3	Connects the external \overline{LOAD} signal to the J21-9 pin of the J21 connector

MAX19000 Evaluation Kit

Evaluates: MAX19000

Table 1. Digital Interface Jumper Settings (continued)

JUMPER	SHUNT POSITION	DESCRIPTION
JU18	1-2*	Connects the DGS pin of the MAX19000 to the ground
	Open	Disconnects the DGS pin of the MAX19000 from the ground
JU23	1-2*	Connects the GNDDAC0 pin of the MAX19000 to the ground
	Open	Disconnects the GNDDAC0 pin of the MAX19000 from the ground
JU24	1-2*	Connects the GNDDAC1 pin of the MAX19000 to the ground
	Open	Disconnects the GNDDAC1 pin of the MAX19000 from the ground

*Default position.

Table 2. Power Supplies Jumper Settings

JUMPER	SHUNT POSITION	DESCRIPTION
JU1	1-2	Connects the ADJ pin of the regulator (U15) to ground through a 280Ω resistor (R3) in parallel with a 402Ω resistor (R5)
	Open*	Disconnects the ADJ pin of the regulator from R3
JU2	1-2	Connects the ADJ pin of the regulator (U15) to ground through a 2.26kΩ resistor (R4)
	Open*	Disconnects the ADJ pin of the regulator from R4
JU3	1-2*	Connects the VT_C to the on-board regulator (U17)
	Open	Disconnects the 1.25V (VT_C) from the on-board regulator (U17)
JU15	1-2	Connects the ADJ pin of the regulator (U16) to ground through a 75Ω resistor (R6) in parallel with a 402Ω resistor (R8)
	Open*	Disconnects the ADJ pin of the regulator from R6
JU16	1-2*	Connects the ADJ pin of the regulator (U16) to ground through a 249Ω resistor (R7) in parallel with a 402Ω resistor (R8)
	Open	Disconnects the ADJ pin of the regulator from R7
JU19	1-2*	Connects VCC to the on-board regulator (U14)
	Open	Disconnects VCC from the on-board regulator (U14)
JU20	1-2*	Connects VDD to the on-board regulator (U15)
	Open	Disconnects VDD from the on-board regulator (U15)
JU21	1-2*	Connects VT_DT to the on-board regulator (U16)
	Open	Disconnects VT_DT from the on-board regulator (U16)
JU22	1-2*	Connects VEE to the negative power supply input jack
	Open	Disconnects VEE from the negative input power supply

*Default position.

MAX19000 Evaluation Kit

Evaluates: MAX19000

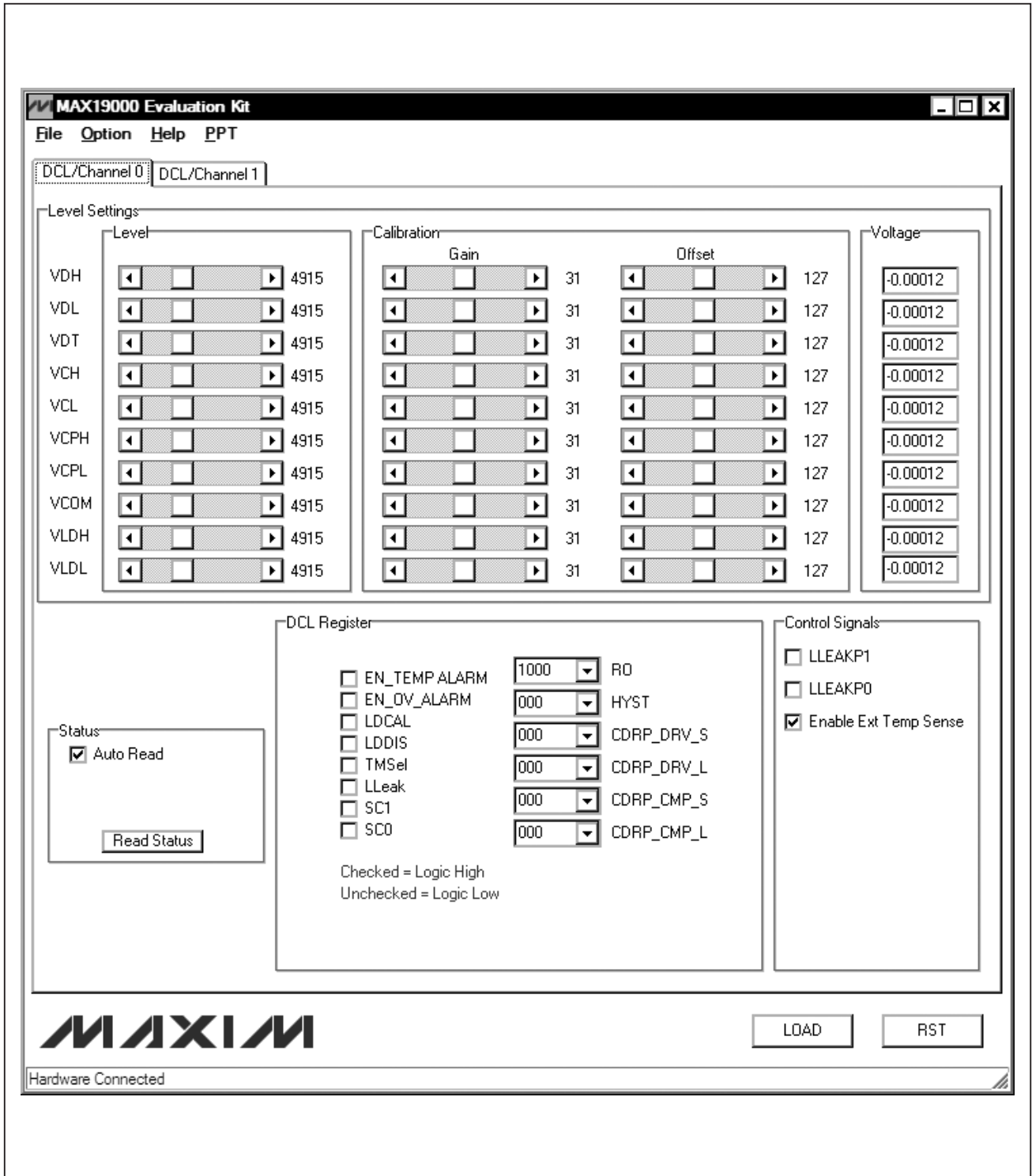

Figure 1. MAX19000 EV Kit Software Main Window (DCL/Channel 0 Tab)

MAX19000 Evaluation Kit

Evaluates: MAX19000

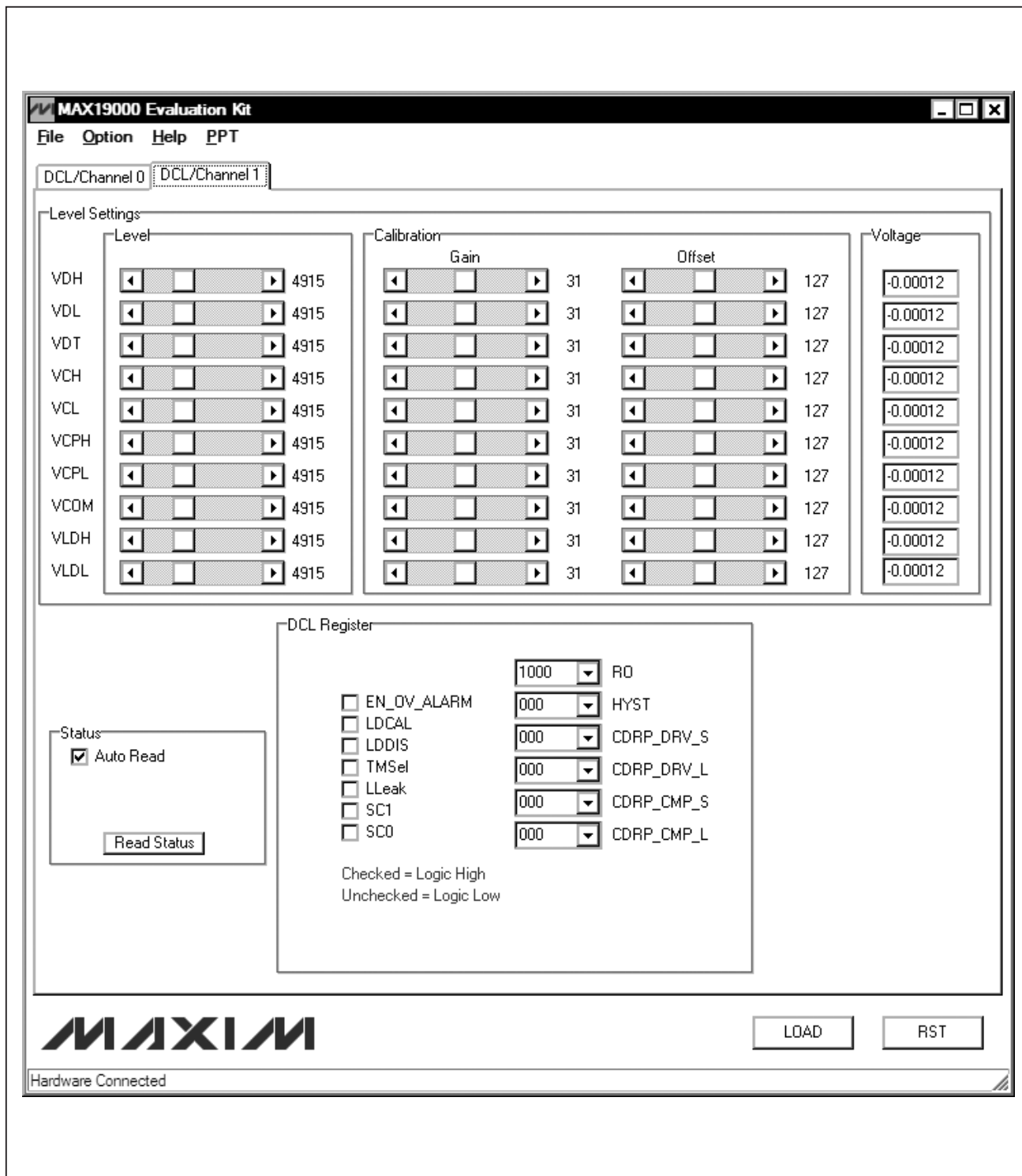

Figure 2. MAX19000 EV Kit Software Main Window (DCL/Channel 1 Tab)

MAX19000 Evaluation Kit

Evaluates: MAX19000

Detailed Description of Software

User-Interface Panel

The GUI contains two DCL tab sheets for channels 0 and 1 for all level, register, and control-signal settings. The **File** menu item has save and load functions for all of the settings.

Driver/Comparator/Load (DCL) Settings

DCL/Channel 0 and **DCL/Channel 1** tab sheets (Figures 1 and 2) are identical and are for channels 0 and 1, respectively. These tab sheets contain **Level Settings** and **DCL Register** group boxes.

Level Settings

The **Level Settings** group box contains registers for signal level, calibration, and gain settings for VDH, VDL, VDT, VCH, VCL, VCPH, VCPL, VCOM, VLDH, and VLDL. Each setting is controlled by a scrollbar with a value label to its right. Finer adjustments can be made by clicking on the arrows on each side of the scrollbar. The scrollbars in the **Level** group box have 16,384 steps corresponding to 14 bits. In the **Calibration** group box, the **Offset** scrollbars have 256 steps corresponding to 8 bits, and the **Gain** scrollbars have 64 steps corresponding to 6 bits. The corresponding voltage levels are also calculated and shown in the edit boxes inside the **Voltage** group box. The value, calibration, and gain selections become effective immediately after an adjustment without having to press the **LOAD** button. The value can also be typed into the edit boxes inside the **Voltage** group box. Pressing the Enter key on the keyboard loads the values to the device.

DCL Register

The **DCL Register** group box contains eight checkboxes to control the DCL register. A checked checkbox represents a logic-high and an unchecked checkbox represents a logic-low. Any change in state of the checkbox immediately sends the new bit setting to the device.

The **DCL Register** group box also has six drop-down lists that control the driver output impedance, comparator hysteresis, and driver/comparator cable-droop compensation.

Save/Load Settings

All settings specified by the GUI can be saved to a file by selecting the **File | Save Setup** menu item located at the front of the menu bar. Settings saved in a file can also be loaded to the GUI and the MAX19000 using the same procedure of selecting the **File | Load Setup** menu item. Use the save-and-load feature to save many different setups, which can be recalled at a later time.

Advanced User Interface

There are two methods for communicating with the MAX19000. The first is through the windows shown in Figures 1 and 2. The second is through the **Advanced User Interface** window. The **Advanced User Interface** window, available by selecting the **Option | Interface (Advanced User)** menu item, allows execution of serial commands manually.

The **Advanced User Interface** window can also be used as a debug tool since it is capable of manually reading and writing to every register of the MAX19000.

Detailed Description of Hardware

The MAX19000 evaluation kit (EV kit) is a fully assembled and tested PCB that evaluates the MAX19000 dual pin driver. The EV kit includes SMA connections for the high-speed digital I/Os and the MAX19000 pin-driver outputs. The MAX19000 EV kit is connected to the PC through the universal serial bus (USB) port.

Power Supplies

Connect the power supplies using the high-current-rated banana jacks, J24 (-5.25V) and J20 (+15V). Common to all power supplies should be the GND banana jack, J22 (GND) on the MAX19000 EV kit. All power supplies should be within the range specified on the MAX19000 IC data sheet. The MAX19000 needs only two supplies attached to the board. All other supplies are generated through regulators on the EV kit board.

MAX19000 Evaluation Kit

Evaluates: MAX19000

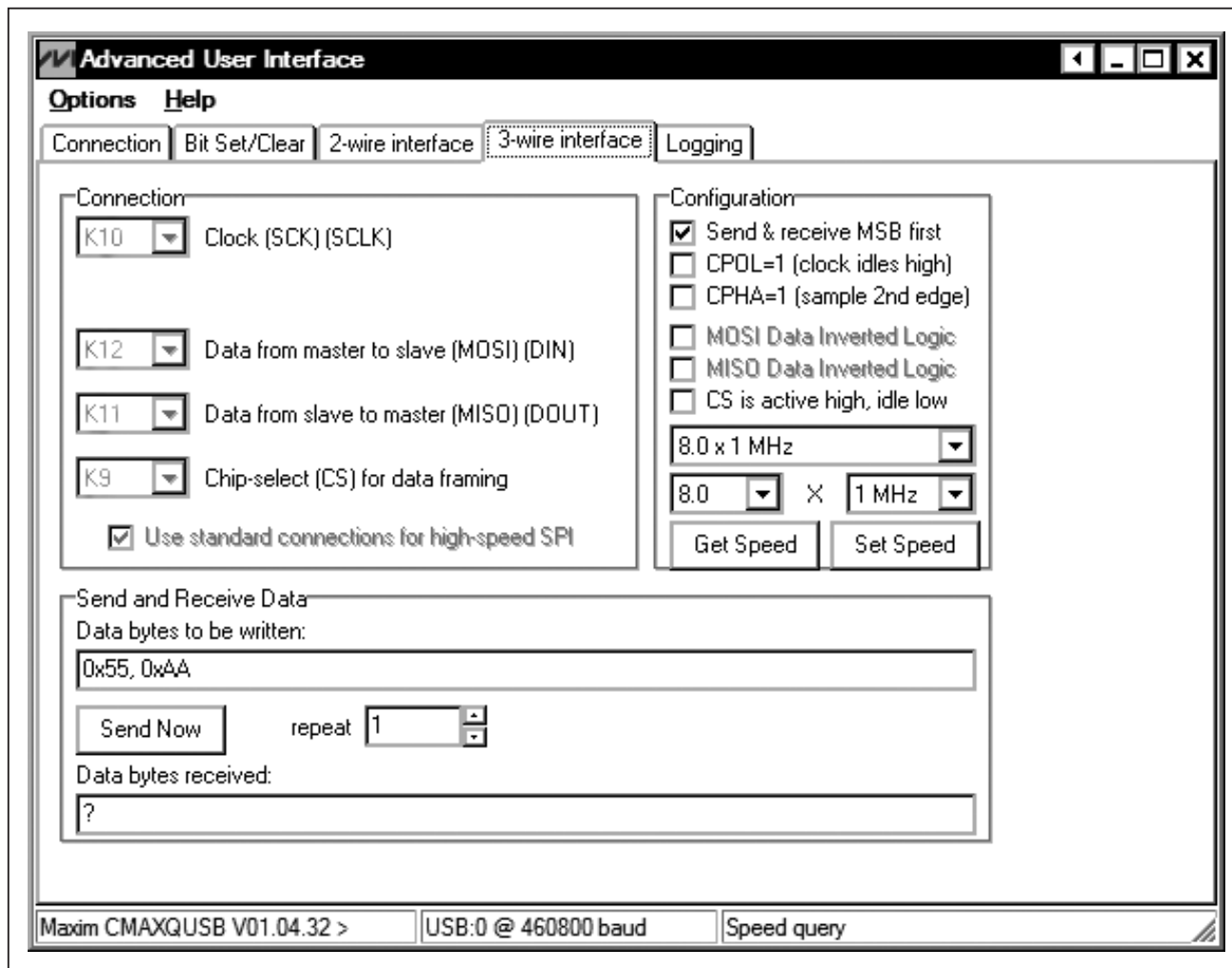

Figure 3. Advanced User Interface Window (3-Wire Interface Tab)

MAX19000 Evaluation Kit

Evaluates: MAX19000

Table 3. Test Points and Their Functions

TEST POINT	SIGNAL	FUNCTION
TMPSNS	TEMPSNS	MAX19000 die temperature indicator
TP1	DIN	Serial-data input
TP2	$\overline{\text{LLEAKP0}}$	Low-leakage enable, channel 0
TP3	$\overline{\text{LLEAKP1}}$	Low-leakage enable, channel 1
TP12	DOUT	Serial-data output
TP14	SCLK	Serial clock
TP15	$\overline{\text{CS}}$	Chip select
TP16	$\overline{\text{LOAD}}$	Load
TP17	$\overline{\text{RST}}$	Serial reset

High-Speed Digital I/Os

The top and bottom edges of the PCB are populated with end-launch SMA connectors, and are the high-speed digital I/Os of the MAX19000. The inputs are terminated internally to the MAX19000 IC. The outputs require termination (nominally 50Ω) at the end of the attached cable.

The board power supply (VRCV) is the voltage used to terminate the comparator outputs on the MAX19000 IC. Setting VRCV to +1.2V makes the high-speed digital I/Os compatible with LVDS levels.

The high-speed digital inputs (DATA0/NDATA0, RCV0/NRCV0, DATA1/NDATA1, and RCV1/NRCV1) are intended for use with a high-speed differential signal source such as LVDS, LVPECL, etc. If only a single-ended stimulus source is available, a converter consisting of a 1:1 ratio transformer can be used to produce a differential pair of inputs for DATA0/NDATA0 or DATA1/NDATA1. A tri-resistor network can be used to produce a differential logic level for RCV0/NRCV0 or RCV1/NRCV1 inputs.

The high-speed digital outputs (CL0/NCL0, CH0/NCH0, CL1/NCL1, and CH1/NCH1) are intended for use with a high-speed differential logic analyzer. These outputs are internally pulled up to the VCTV voltage through internal 50Ω resistors. These outputs can be double-terminated at the measurement source by external 50Ω resistors.

Pin-Driver Outputs

The two pin-driver outputs (DUT0 and DUT1) are through end-launch SMA connectors on the right-edge of the PCB. The outputs have a typical output impedance of 50Ω, but this can be adjusted by software.

Test Points

There are nine test points on the MAX19000 EV kit to facilitate performance analysis and circuit modification. These test points are listed in Table 3.

Device Ground Sense

The MAX19000 IC has the ability to sense the ground potential at the device under test (DUT). The MAX19000 EV kit is preconfigured to have the device ground sense (DGS) pin connected to the ground plane. If remote sensing is desired, remove the shunt on jumper JU18 and connect the pin 1 of JU18 to the remote DUT ground.

Temperature Sensing

The MAX19000 EV kit provides the means to determine the MAX19000 IC's die temperature through the TMPSNS test point. During operation, TMPSNS should be continuously monitored to ensure that the junction temperature does not exceed +150°C, which corresponds with +4.2V. During normal operation, a voltage of +3V to +3.6V is typical.

Evaluates: MAX19000

MAX19000 Evaluation Kit

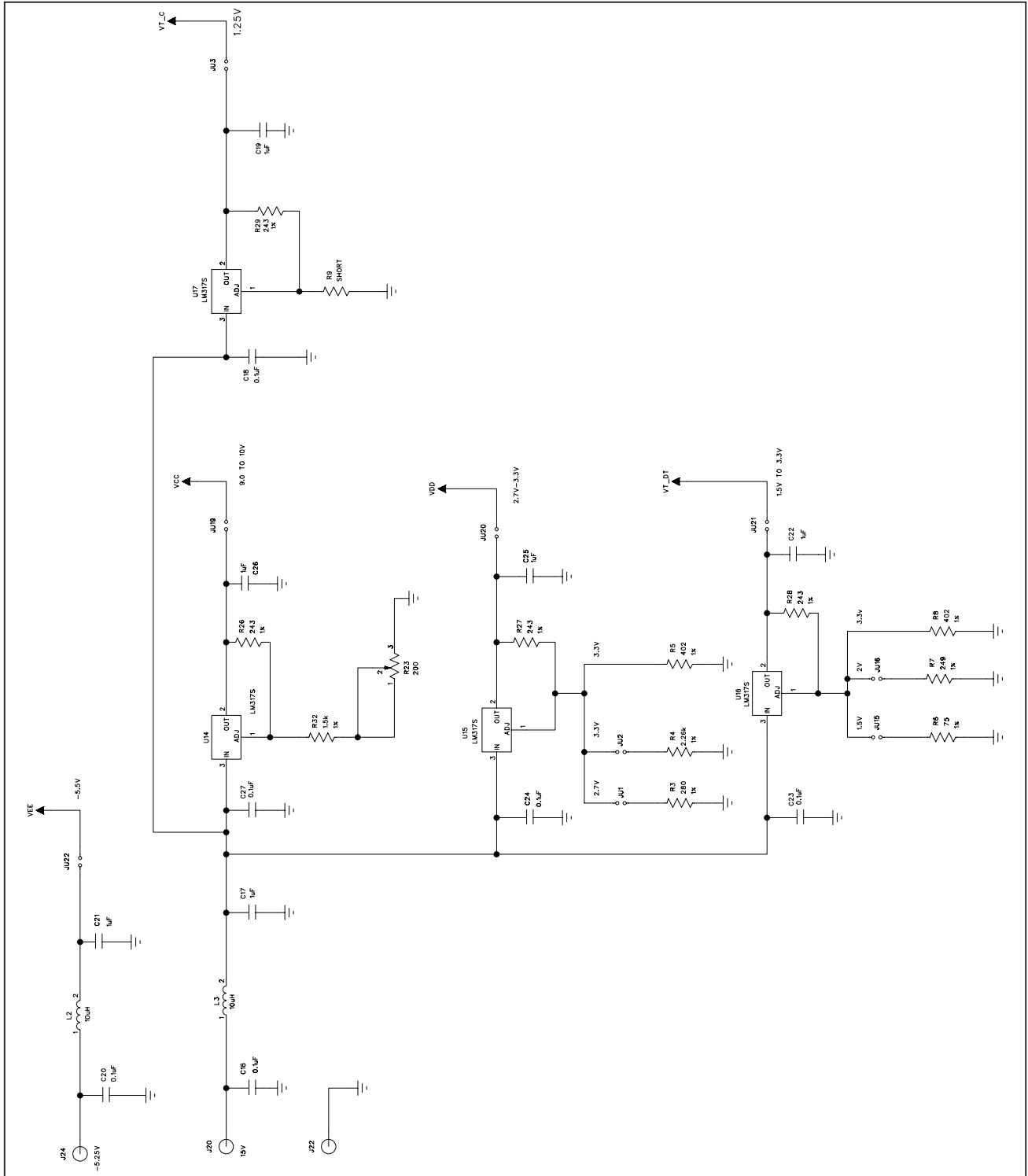
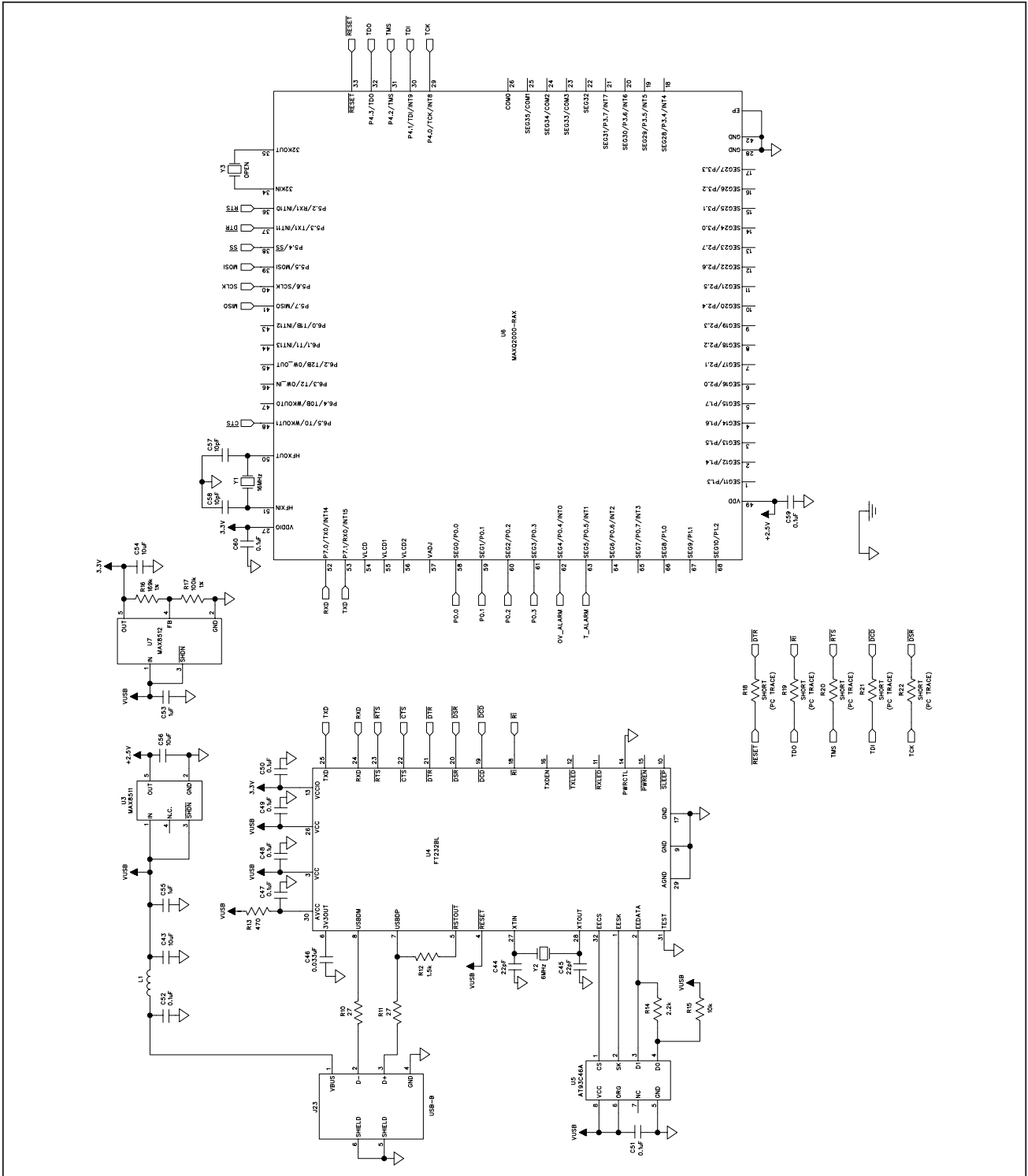

Figure 4b. MAX19000 EV Kit Schematic (Sheet 2 of 4)

MAX19000 Evaluation Kit

Evaluates: MAX19000



Evaluates: MAX19000

MAX19000 Evaluation Kit

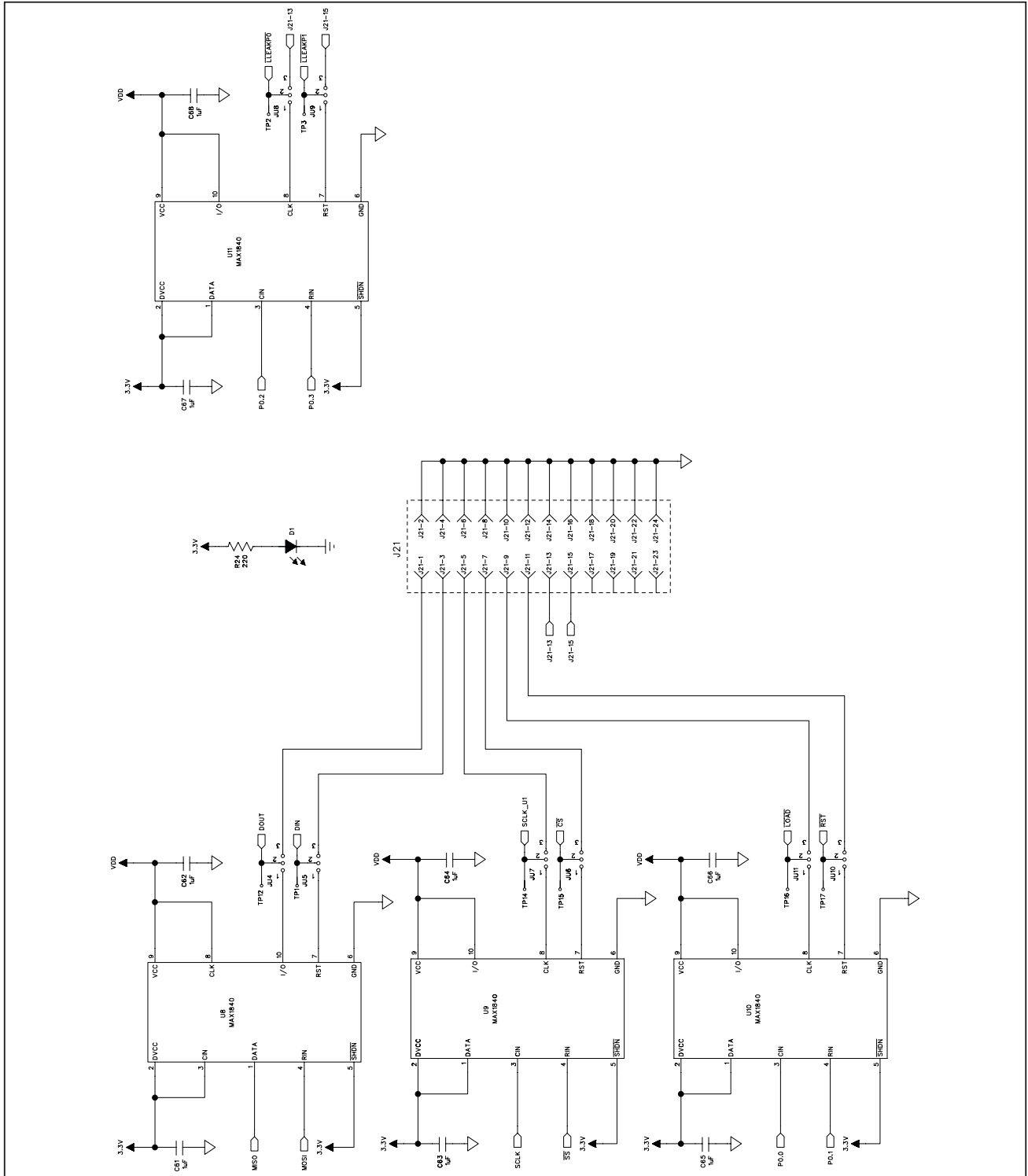

Figure 4d. MAX19000 EV Kit Schematic (Sheet 4 of 4)

MAX19000 Evaluation Kit

Evaluates: MAX19000

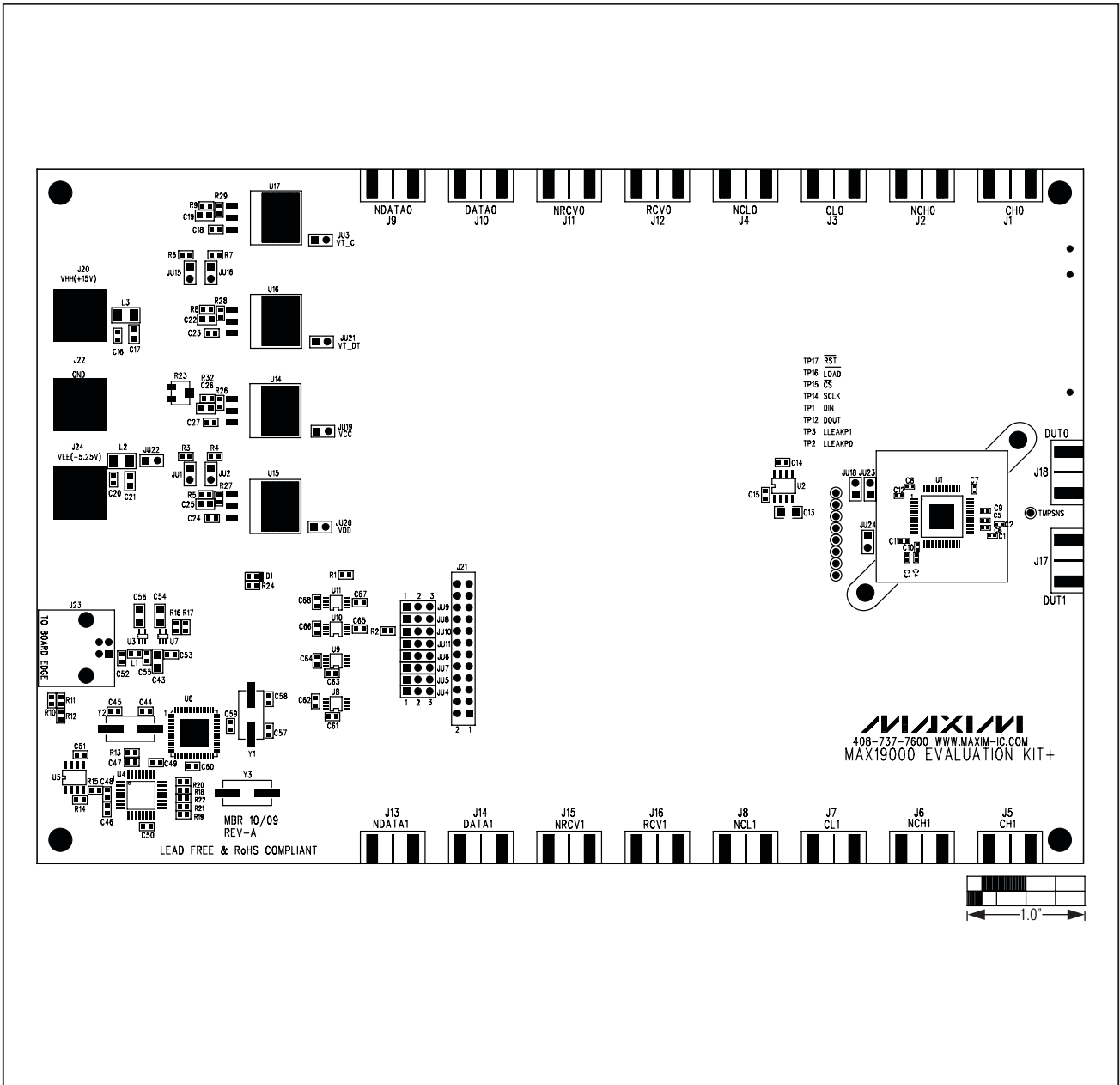

Figure 5. MAX19000 EV Kit Component Placement Guide—Top Side

MAX19000 Evaluation Kit

Evaluates: MAX19000

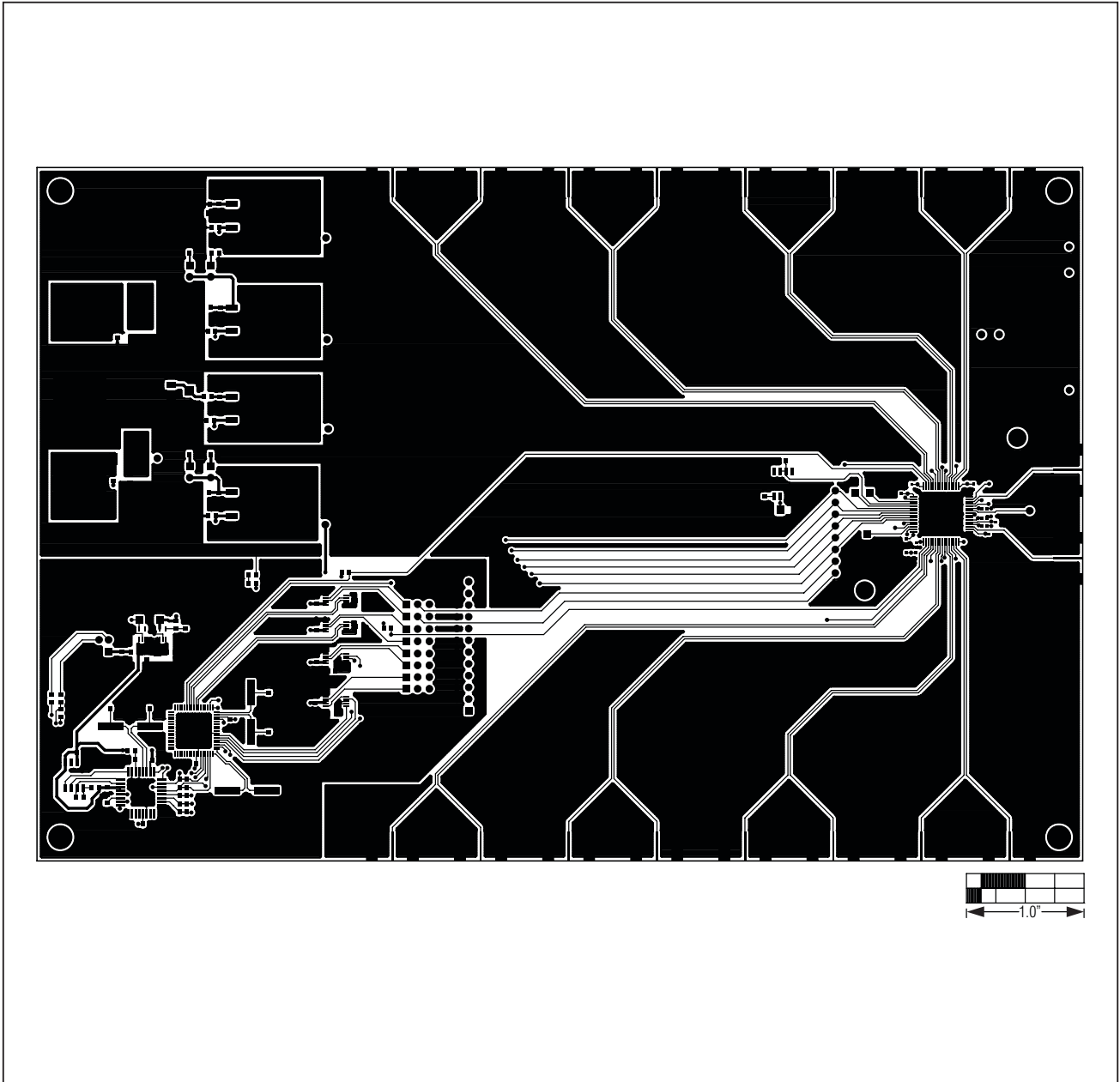

Figure 6. MAX19000 EV Kit PCB Layout—Component Side

MAX19000 Evaluation Kit

Evaluates: MAX19000

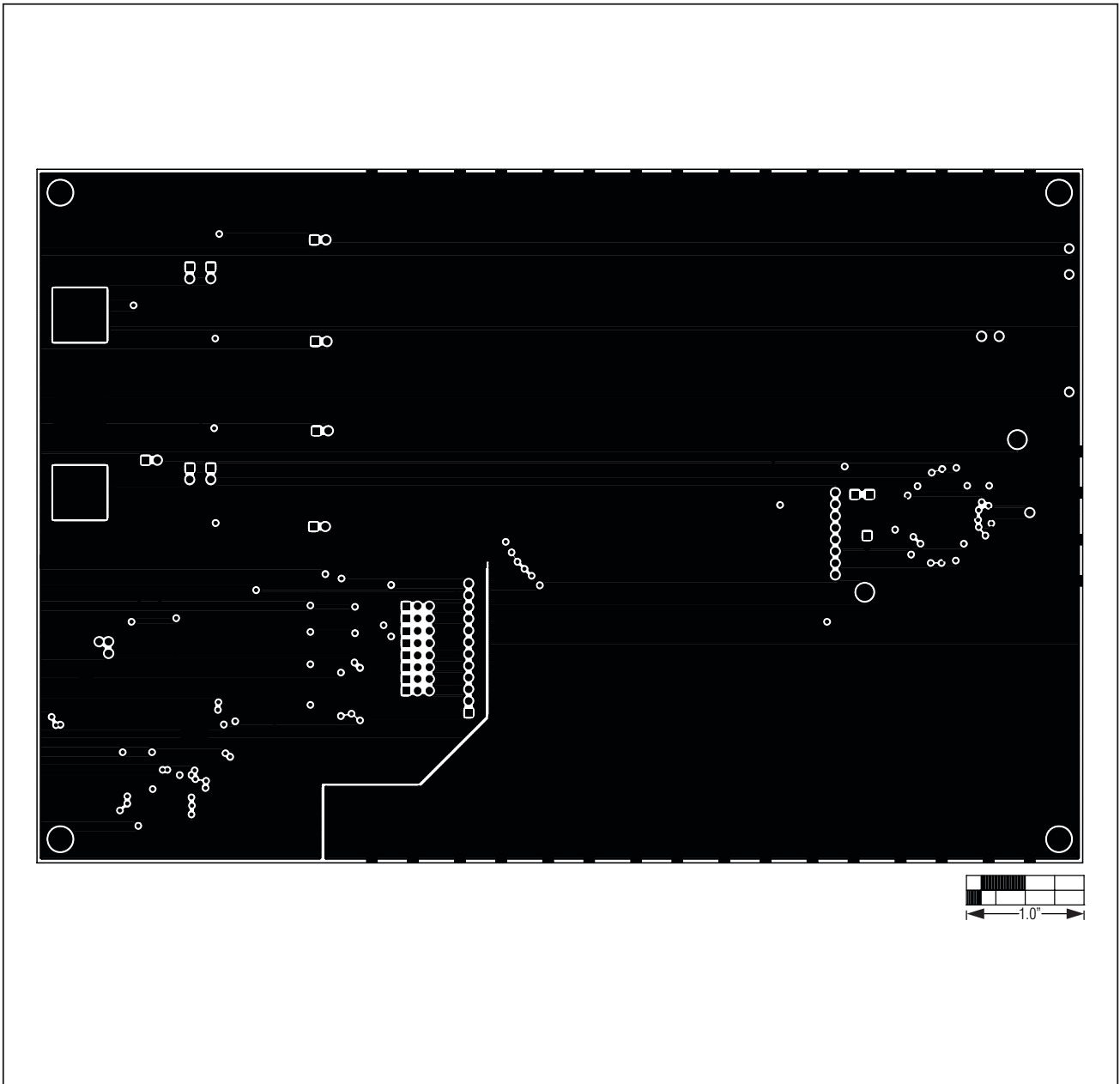

Figure 7. MAX19000 EV Kit PCB Layout—Layer 2

MAX19000 Evaluation Kit

Evaluates: MAX19000

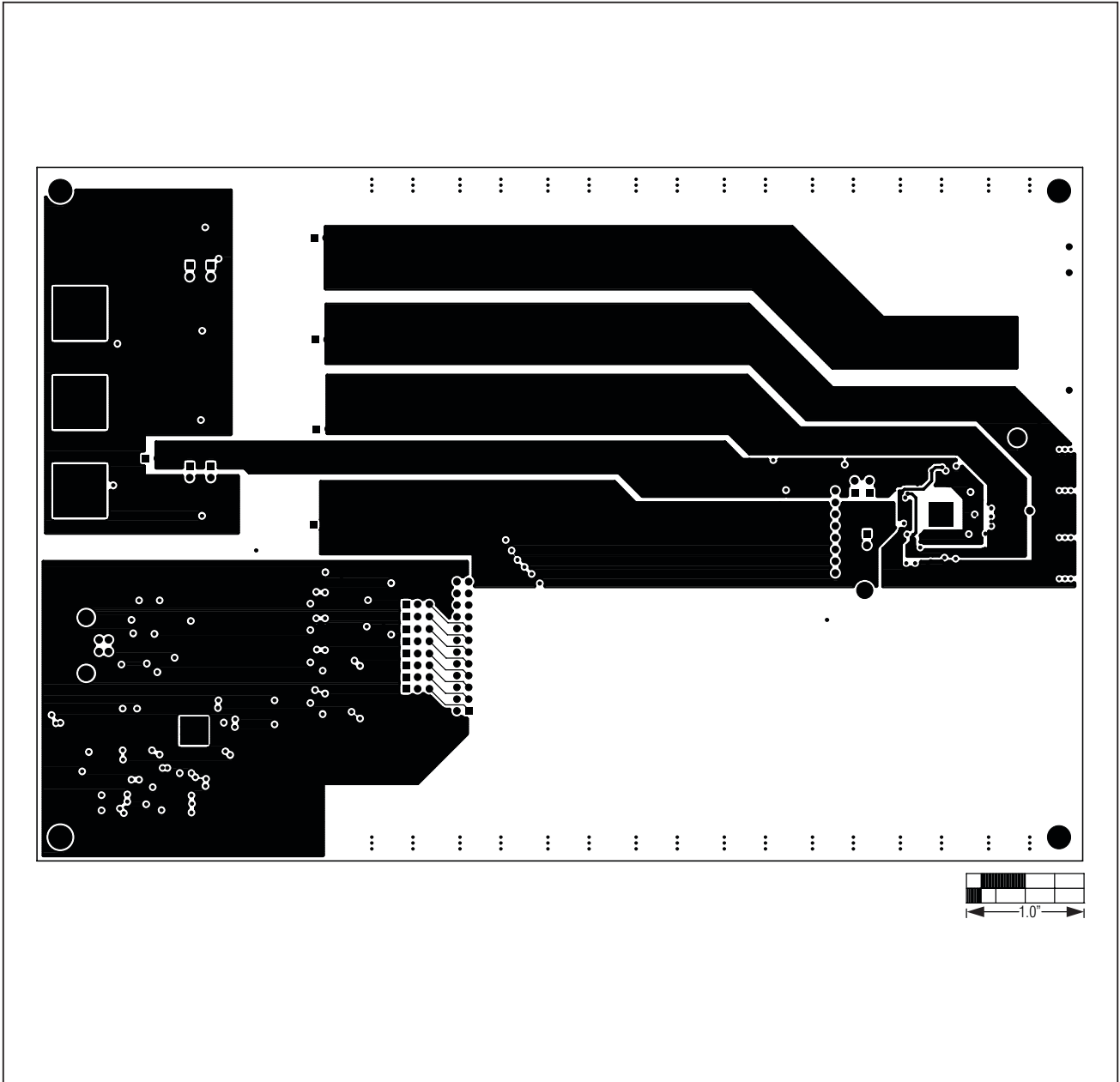

Figure 8. MAX19000 EV Kit PCB Layout—Layer 3

MAX19000 Evaluation Kit

Evaluates: MAX19000

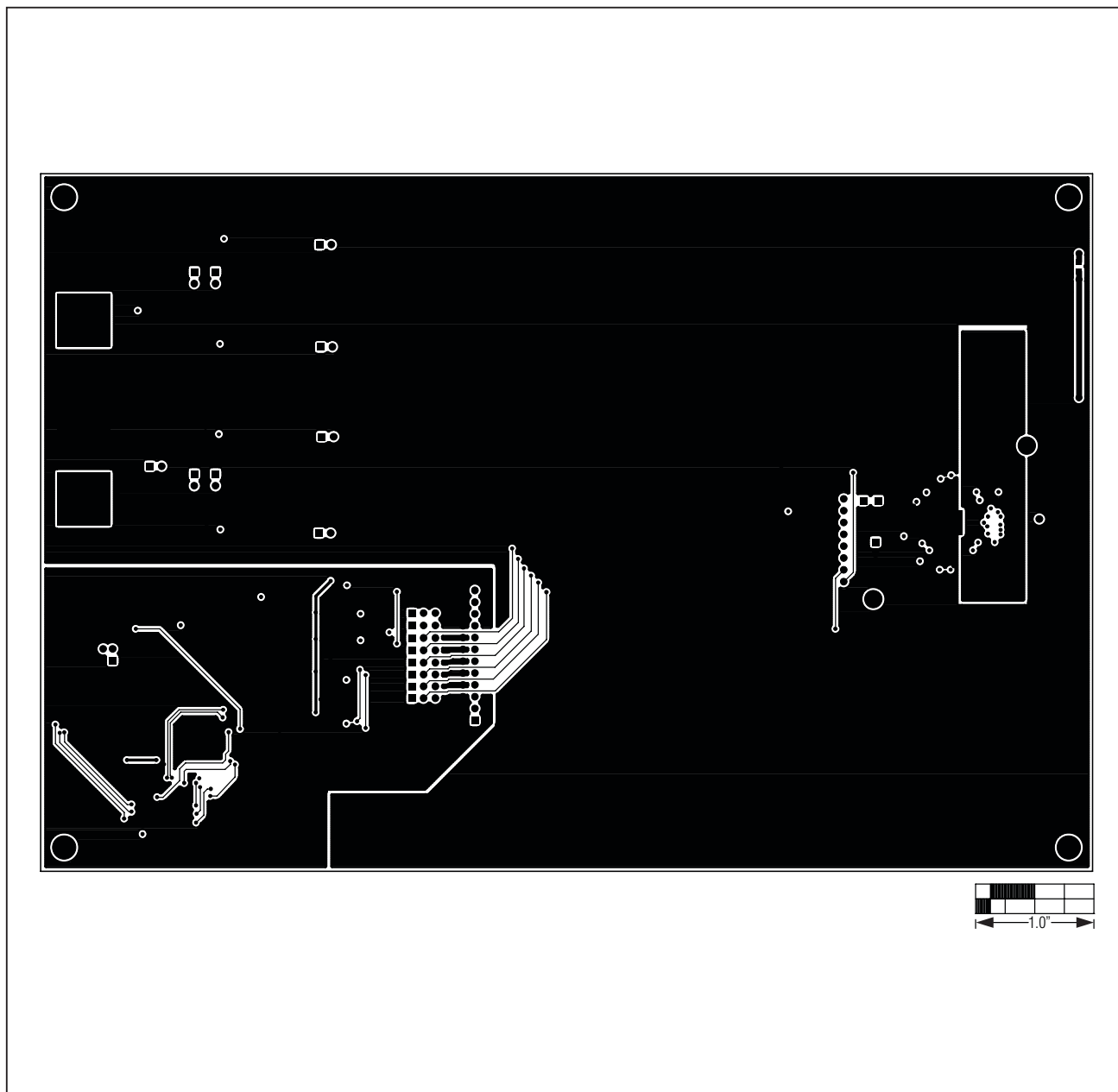

Figure 9. MAX19000 EV Kit PCB Layout—Bottom Side

Maxim cannot assume responsibility for use of any circuitry other than circuitry entirely embodied in a Maxim product. No circuit patent licenses are implied. Maxim reserves the right to change the circuitry and specifications without notice at any time.

Maxim Integrated Products, 120 San Gabriel Drive, Sunnyvale, CA 94086 408-737-7600 _____ **19**