

## **Excellent Integrated System Limited**

Stocking Distributor

Click to view price, real time Inventory, Delivery & Lifecycle Information:

[Infineon Technologies](#)

[BTS7710G](#)

For any questions, you can email us directly:

[sales@integrated-circuit.com](mailto:sales@integrated-circuit.com)



**TrilithIC**

**BTS 7710 G**

**Data Sheet**

**1 Overview**

**1.1 Features**

- Quad D-MOS switch driver
- Free configurable as bridge or quad-switch
- Optimized for DC motor management applications
- Low  $R_{DS\ ON}$ : 70 m $\Omega$  high-side switch, 40 m $\Omega$  low-side switch (typical values @ 25 °C)
- Maximum peak current: typ. 15 A @ 25 °C
- Very low quiescent current: typ. 5  $\mu$ A @ 25 °C
- Small outline, enhanced power P-DSO-package
- Load and GND-short-circuit-protection
- Operates up to 40 V
- Status flag diagnosis
- Overtemperature shut down with hysteresis
- Internal clamp diodes
- Isolated sources for external current sensing
- Under-voltage detection with hysteresis
- PWM frequencies up to 50 kHz

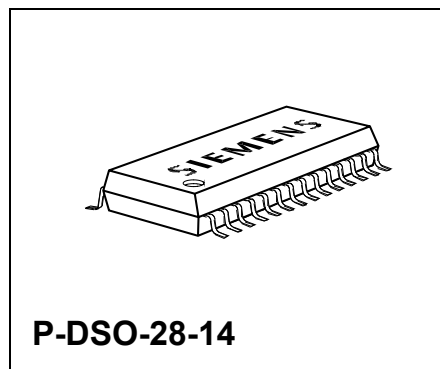

Type	Ordering Code	Package
BTS 7710 G	Q67007-A9399	P-DSO-28-14

**1.2 Description**

The **BTS 7710 G** is part of the **TrilithIC** family containing three dies in one package: One double high-side switch and two low-side switches. The drains of these three vertical DMOS chips are mounted on separated leadframes. The sources are connected to individual pins, so the **BTS 7710 G** can be used in H-bridge- as well as in any other configuration. The double high-side is manufactured in **SMART SIPMOS**<sup>®</sup> technology which combines low  $R_{DS\ ON}$  vertical DMOS power stages with CMOS control circuitry. The high-side switch is fully protected and contains the control and diagnosis circuitry. To achieve low  $R_{DS\ ON}$  and fast switching performance, the low-side switches are manufactured in **S-FET** logic level technology. The equivalent standard product is the **BUZ 103 SL**.

In contrast to the **BTS 7710 GP**, which consists of the same chips in an **P-TO263-15** package, the **P-DSO-28-14** package offers a smaller outline and a lower price for applications, which do not need the thermal properties of the **P-TO263-15**.

**1.3 Pin Configuration**  
(top view)

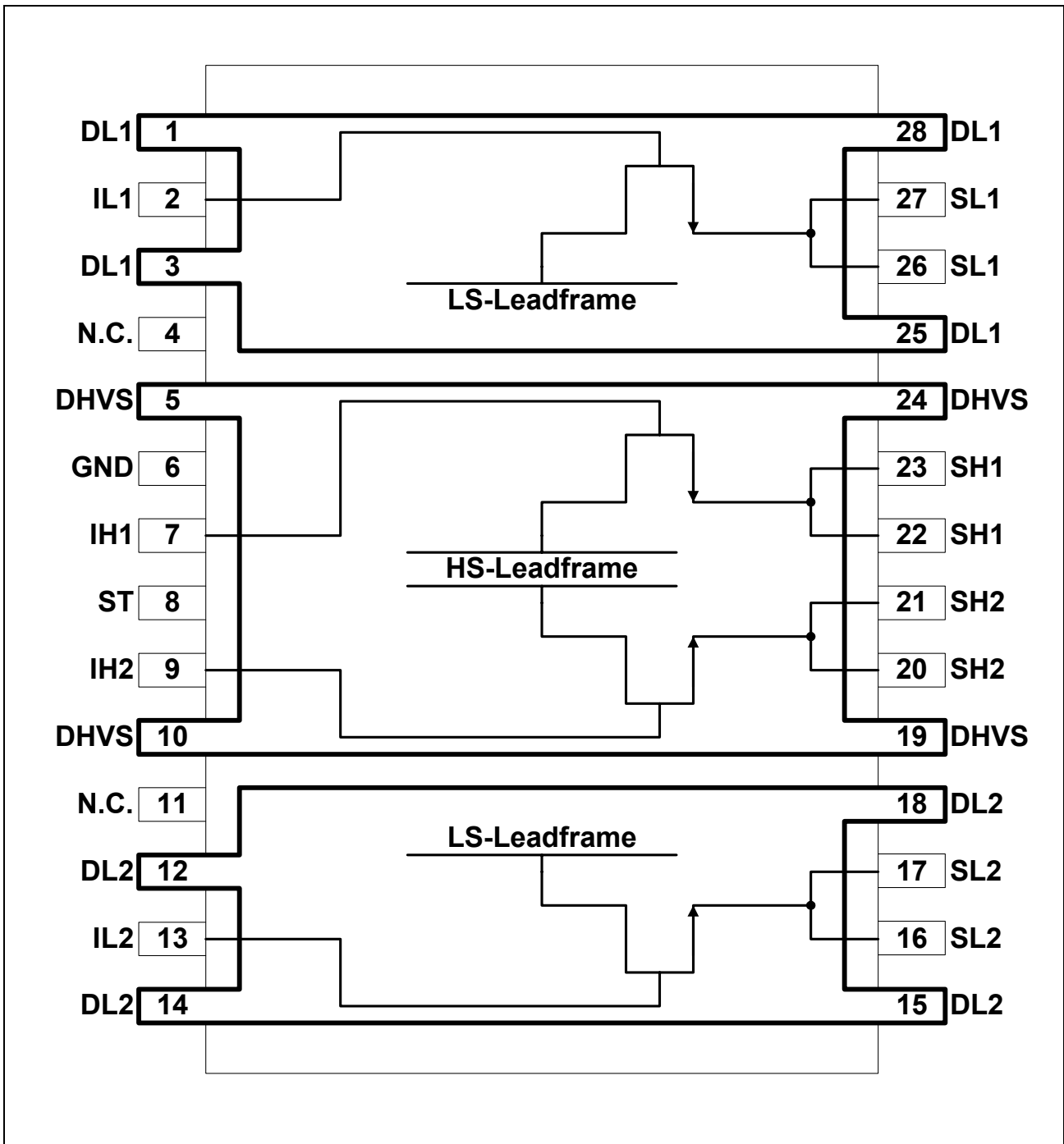

Figure 1



#### 1.4 Pin Definitions and Functions

Pin No.	Symbol	Function
<b>1, 3, 25, 28</b>	<b>DL1</b>	<b>Drain of low-side switch1, leadframe 1 <sup>1)</sup></b>
2	IL1	Analog input of low-side switch1
4	N.C.	not connected
<b>5, 10, 19, 24</b>	<b>DHVS</b>	<b>Drain of high-side switches and power supply voltage, leadframe 2 <sup>1)</sup></b>
6	GND	Ground
7	IH1	Digital input of high-side switch1
8	ST	Status of high-side switches; open Drain output
9	IH2	Digital input of high-side switch2
11	N.C.	not connected
<b>12, 14, 15, 18</b>	<b>DL2</b>	<b>Drain of low-side switch2, leadframe 3 <sup>1)</sup></b>
13	IL2	Analog input of low-side switch2
<b>16,17</b>	<b>SL2</b>	<b>Source of low-side switch2</b>
<b>20,21</b>	<b>SH2</b>	<b>Source of high-side switch2</b>
<b>22,23</b>	<b>SH1</b>	<b>Source of high-side switch1</b>
<b>26,27</b>	<b>SL1</b>	<b>Source of low-side switch1</b>

<sup>1)</sup> To reduce the thermal resistance these pins are direct connected via metal bridges to the leadframe.

Pins written in **bold type** need power wiring.

**1.5 Functional Block Diagram**

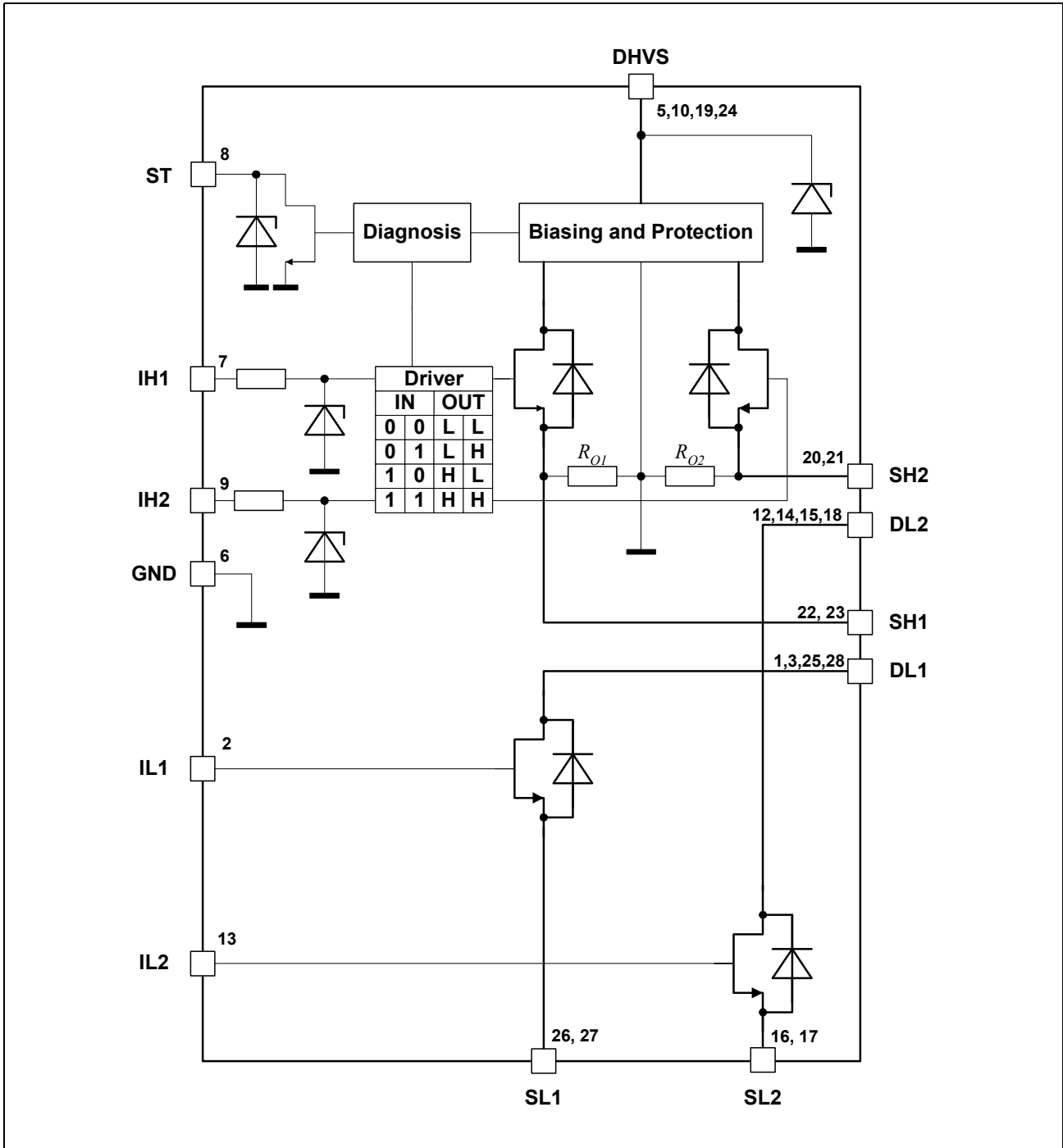

**Figure 2**  
**Block Diagram**



## 1.6 Circuit Description

### Input Circuit

The control inputs IH1,2 consist of TTL/CMOS compatible Schmitt-Triggers with hysteresis. Buffer amplifiers are driven by these stages and convert the logic signal into the necessary form for driving the power output stages. The inputs are protected by ESD clamp-diodes.

The inputs IL1 and IL2 are connected to the gates of the standard N-channel vertical power-MOS-FETs.

### Output Stages

The output stages consist of an low  $R_{DS\ ON}$  Power-MOS H-bridge. In H-bridge configuration, the D-MOS body diodes can be used for freewheeling when commutating inductive loads. If the high-side switches are used as single switches, positive and negative voltage spikes which occur when driving inductive loads are limited by integrated power clamp diodes.

### Short Circuit Protection

The outputs are protected against

- output short circuit to ground
- overload (load short circuit).

An internal OP-Amp controls the Drain-Source-Voltage by comparing the DS-Voltage-Drop with an internal reference voltage. Above this trippoint the OP-Amp reduces the output current depending on the junction temperature and the drop voltage.

In the case of overloaded high-side switches the status output is set to low.

### Overtemperature Protection

The high-side switches incorporate an overtemperature protection circuit with hysteresis which switches off the output transistors and sets the status output to low.

### Undervoltage-Lockout (UVLO)

When  $V_S$  reaches the switch-on voltage  $V_{UVON}$  the IC becomes active with a hysteresis. The High-Side output transistors are switched off if the supply voltage  $V_S$  drops below the switch off value  $V_{UVOFF}$ .



## Status Flag

The status flag output is an open drain output with Zener-diode which requires a pull-up resistor, c.f. the application circuit on page 14. Various errors as listed in the table “Diagnosis” are detected by switching the open drain output ST to low. A open load detection is not available. Freewheeling condition does not cause an error.

## 2 Truthtable and Diagnosis (valid only for the High-Side-Switches)

Flag	IH1	IH2	SH1	SH2	ST	Remarks
	Inputs		Outputs			
Normal operation; identical with functional truth table	0	0	L	L	1	stand-by mode switch2 active switch1 active both switches active
	0	1	L	H	1	
	1	0	H	L	1	
	1	1	H	H	1	
Overtemperature high-side switch1	0	X	L	X	1	detected
	1	X	L	X	0	
Overtemperature high-side switch2	X	0	X	L	1	detected
	X	1	X	L	0	
Overtemperature both high-side switches	0	0	L	L	1	detected detected
	X	1	L	L	0	
	1	X	L	L	0	
Undervoltage	X	X	L	L	1	not detected

### Inputs:

0 = Logic LOW  
 1 = Logic HIGH  
 X = don't care

### Outputs:

Z = Output in tristate condition  
 L = Output in sink condition  
 H = Output in source condition  
 X = Voltage level undefined

### Status:

1 = No error  
 0 = Error

### 3 Electrical Characteristics

#### 3.1 Absolute Maximum Ratings

$$-40\text{ }^{\circ}\text{C} < T_j < 150\text{ }^{\circ}\text{C}$$

Parameter	Symbol	Limit Values		Unit	Remarks
		min.	max.		

#### High-Side-Switches (Pins DHVS, IH1,2 and SH1,2)

Supply voltage	$V_S$	- 0.3	42	V	-
Supply voltage for full short circuit protection	$V_{S(SCP)}$		28	V	-
HS-drain current*	$I_S$	- 8	**	A	$T_A = 25^{\circ}\text{C}; t < 100\text{ ms}$
HS-input current	$I_{IH}$	- 5	5	mA	Pin IH1 and IH2
HS-input voltage	$V_{IH}$	- 10	16	V	Pin IH1 and IH2

Note: \* single pulse      \*\* internally limited

#### Status Output ST

Status pull up voltage	$V_{ST}$	- 0.3	5.4	V	-
Status Output current	$I_{ST}$	- 5	5	mA	Pin ST

#### Low-Side-Switches (Pins DL1,2, IL1,2 and SL1,2)

Drain- source break down voltage	$V_{DSL}$	55	-	V	$V_{IL} = 0\text{ V}; I_D \leq 1\text{ mA}$
LS-drain current* $T_A = 25^{\circ}\text{C}$	$I_{DL}$	-8	8	A	$t < 100\text{ ms}$
		-	11	A	$t < 10\text{ ms}$
		-	24	A	$t < 1\text{ ms}$
LS-input voltage	$V_{IL}$	- 20	20	V	Pin IL1 and IL2

Note: \* single pulse

#### Temperatures

Junction temperature	$T_j$	- 40	150	$^{\circ}\text{C}$	-
Storage temperature	$T_{stg}$	- 55	150	$^{\circ}\text{C}$	-





## BTS 7710 G

### 3.1 Absolute Maximum Ratings (cont'd) $-40\text{ }^{\circ}\text{C} < T_j < 150\text{ }^{\circ}\text{C}$

Parameter	Symbol	Limit Values		Unit	Remarks
		min.	max.		

#### Thermal Resistances (one HS-LS-Path active)

LS-junction case	$R_{thjCL}$	–	20	K/W	measured to pin 3 or 12
HS-junction case	$R_{thjCH}$	–	20	K/W	measured to pin 19
Junction ambient $R_{thja} = T_{j(HS)}/(P_{(HS)}+P_{(LS)})$	$R_{thja}$	–	60	K/W	device soldered to reference PCB with 6 cm <sup>2</sup> cooling area

#### ESD Protection (Human Body Model acc. MIL STD 883D, method 3015.7 and EOS/ESD assn. standard S5.1 - 1993)

Input LS-Switch	$V_{ESD}$	–	0.5	kV	
Input HS-Switch	$V_{ESD}$	–	1	kV	
Status HS-Switch	$V_{ESD}$	–	2	kV	
Output LS and HS-Switch	$V_{ESD}$	–	8	kV	all other pins connected to Ground

*Note: Maximum ratings are absolute ratings; exceeding any one of these values may cause irreversible damage to the integrated circuit.*

### 3.2 Operating Range $-40\text{ }^{\circ}\text{C} < T_j < 150\text{ }^{\circ}\text{C}$

Parameter	Symbol	Limit Values		Unit	Remarks
		min.	max.		
Supply voltage	$V_S$	$V_{UVOFF}$	42	V	After $V_S$ rising above $V_{UVON}$
Input voltages HS	$V_{IH}$	– 0.3	15	V	–
Input voltages LS	$V_{IL}$	– 0.3	20	V	–
Output current	$I_{ST}$	0	2	mA	–
Junction temperature	$T_j$	– 40	150	°C	–

*Note: In the operating range the functions given in the circuit description are fulfilled.*

### 3.3 Electrical Characteristics

$I_{SH1} = I_{SH2} = I_{SL1} = I_{SL2} = 0 \text{ A}$ ;  $-40 \text{ }^\circ\text{C} < T_j < 150 \text{ }^\circ\text{C}$ ;  $8 \text{ V} < V_S < 18 \text{ V}$   
 unless otherwise specified

Parameter	Symbol	Limit Values			Unit	Test Condition
		min.	typ.	max.		

#### Current Consumption HS-switch

Quiescent current	$I_S$	–	5	8	$\mu\text{A}$	$I_{H1} = I_{H2} = 0 \text{ V}$ $T_j = 25 \text{ }^\circ\text{C}$
		–	–	12	$\mu\text{A}$	$I_{H1} = I_{H2} = 0 \text{ V}$
Supply current	$I_S$	–	1.5	2.6	$\text{mA}$	$I_{H1}$ or $I_{H2} = 5 \text{ V}$ $V_S = 12 \text{ V}$
		–	3	5.2	$\text{mA}$	$I_{H1}$ and $I_{H2} = 5 \text{ V}$ $V_S = 12 \text{ V}$
Leakage current of highside switch	$I_{SHLK}$	–	–	6	$\mu\text{A}$	$V_{IH} = V_{SH} = 0 \text{ V}$
Leakage current through logic GND in free wheeling condition	$I_{LKCL} = I_{FH} + I_{SH}$	–	–	10	$\text{mA}$	$I_{FH} = 3 \text{ A}$

#### Current Consumption LS-switch

Input current	$I_{IL}$	–	10	100	$\text{nA}$	$V_{IL} = 20 \text{ V}$ ; $V_{DSL} = 0 \text{ V}$ $T_j = 25 \text{ }^\circ\text{C}$
Leakage current of lowside switch	$I_{DLK}$	–	–	10	$\mu\text{A}$	$V_{IL} = 0 \text{ V}$ $V_{DSL} = 40 \text{ V}$

#### Under Voltage Lockout (UVLO) HS-switch

Switch-ON voltage	$V_{UVON}$	–	–	4.5	$\text{V}$	$V_S$ increasing
Switch-OFF voltage	$V_{UVOFF}$	1.8	–	3.2	$\text{V}$	$V_S$ decreasing
Switch ON/OFF hysteresis	$V_{UVHY}$	–	1	–	$\text{V}$	$V_{UVON} - V_{UVOFF}$

### 3.3 Electrical Characteristics (cont'd)

$I_{SH1} = I_{SH2} = I_{SL1} = I_{SL2} = 0 \text{ A}$ ;  $-40 \text{ }^\circ\text{C} < T_j < 150 \text{ }^\circ\text{C}$ ;  $8 \text{ V} < V_s < 18 \text{ V}$   
 unless otherwise specified

Parameter	Symbol	Limit Values			Unit	Test Condition
		min.	typ.	max.		

#### Output stages

Inverse diode of high-side switch; Forward-voltage	$V_{FH}$	–	0.8	1.2	V	$I_{FH} = 3 \text{ A}$
Inverse diode of lowside switch; Forward-voltage	$V_{FL}$	–	0.8	1.2	V	$I_{FL} = 3 \text{ A}$
Static drain-source on-resistance of highside switch	$R_{DS\ ON\ H}$	–	70	90	m $\Omega$	$I_{SH} = 1 \text{ A}$ $T_j = 25 \text{ }^\circ\text{C}$
Static drain-source on-resistance of lowside switch	$R_{DS\ ON\ L}$	–	40	50	m $\Omega$	$I_{SL} = 1 \text{ A}$ ; $V_{IL} = 5 \text{ V}$ $T_j = 25 \text{ }^\circ\text{C}$
Static path on-resistance	$R_{DS\ ON}$	–	–	260	m $\Omega$	$R_{DS\ ON\ H} + R_{DS\ ON\ L}$ $I_{SH} = 1 \text{ A}$ ;

#### Short Circuit of highside switch to GND

Initial peak SC current	$I_{SCP\ H}$	15	18	20	A	$T_j = -40 \text{ }^\circ\text{C}$
Initial peak SC current	$I_{SCP\ H}$	13	15	17	A	$T_j = +25 \text{ }^\circ\text{C}$
Initial peak SC current	$I_{SCP\ H}$	9	11	13	A	$T_j = +150 \text{ }^\circ\text{C}$

#### Short Circuit of highside switch to $V_s$

Output pull-down-resistor	$R_O$	8	15	35	k $\Omega$	$V_{DSL} = 3 \text{ V}$
---------------------------	-------	---	----	----	------------	-------------------------

#### Thermal Shutdown

Thermal shutdown junction temperature	$T_{j\ SD}$	155	180	190	$^\circ\text{C}$	–
Thermal switch-on junction temperature	$T_{j\ SO}$	150	170	180	$^\circ\text{C}$	–
Temperature hysteresis	$\Delta T$	–	10	–	$^\circ\text{C}$	$\Delta T = T_{j\ SD} - T_{j\ SO}$

### 3.3 Electrical Characteristics (cont'd)

$I_{SH1} = I_{SH2} = I_{SL1} = I_{SL2} = 0 \text{ A}$ ;  $-40 \text{ }^\circ\text{C} < T_j < 150 \text{ }^\circ\text{C}$ ;  $8 \text{ V} < V_S < 18 \text{ V}$   
 unless otherwise specified

Parameter	Symbol	Limit Values			Unit	Test Condition
		min.	typ.	max.		

#### Status Flag Output ST of highside switch

Low output voltage	$V_{STL}$	–	0.2	0.6	V	$I_{ST} = 1.6 \text{ mA}$
Leakage current	$I_{STLK}$	–	–	10	$\mu\text{A}$	$V_{ST} = 5 \text{ V}$
Zener-limit-voltage	$V_{STZ}$	5.4		–	V	$I_{ST} = 1.6 \text{ mA}$

#### Switching times of highside switch

Turn-ON-time; to 90% $V_{SH}$	$t_{ON}$	–	75	160	$\mu\text{s}$	$R_{Load} = 12 \text{ } \Omega$ $V_S = 12 \text{ V}$
Turn-OFF-time; to 10% $V_{SH}$	$t_{OFF}$	–	60	160	$\mu\text{s}$	$R_{Load} = 12 \text{ } \Omega$ $V_S = 12 \text{ V}$
Slew rate on 10 to 30% $V_{SH}$	$dV/dt_{ON}$	–	–	1.5	V/ $\mu\text{s}$	$R_{Load} = 12 \text{ } \Omega$ $V_S = 12 \text{ V}$
Slew rate off 70 to 40% $V_{SH}$	$-dV/dt_{OFF}$	–	–	2.0	V/ $\mu\text{s}$	$R_{Load} = 12 \text{ } \Omega$ $V_S = 12 \text{ V}$

*Note: switching times are guaranteed by design*

#### Switching times of low-side switch

Turn-ON delay time; $V_{IL} = 5\text{V}$ ; $R_G = 7 \text{ } \Omega$	$t_{d\_ON\_L}$	–	9	14	ns	resistive load $I_{SL} = 3 \text{ A}$ ; $V_S = 30 \text{ V}$
Switch-ON time; $V_{IL} = 5\text{V}$ ; $R_G = 7 \text{ } \Omega$	$t_{ON\_L}$	–	25	40	ns	resistive load $I_{SL} = 3 \text{ A}$ ; $V_S = 30 \text{ V}$
Switch-OFF delay time; $V_{IL} = 5\text{V}$ ; $R_G = 7 \text{ } \Omega$	$t_{d\_OFF\_L}$	–	36	55	ns	resistive load $I_{SL} = 3 \text{ A}$ ; $V_S = 30 \text{ V}$
Switch-OFF time; $V_{IL} = 5\text{V}$ ; $R_G = 7 \text{ } \Omega$	$t_{OFF\_L}$	–	22	33	ns	resistive load $I_{SL} = 3 \text{ A}$ ; $V_S = 30 \text{ V}$

### 3.3 Electrical Characteristics (cont'd)

$I_{SH1} = I_{SH2} = I_{SL1} = I_{SL2} = 0 \text{ A}$ ;  $-40 \text{ }^\circ\text{C} < T_j < 150 \text{ }^\circ\text{C}$ ;  $8 \text{ V} < V_S < 18 \text{ V}$   
 unless otherwise specified

Parameter	Symbol	Limit Values			Unit	Test Condition
		min.	typ.	max.		

#### Gate charge of lowside switch

Input to source charge;	$Q_{IS}$	–	4	6	nC	$I_{SL} = 3 \text{ A}$ ; $V_S = 14 \text{ V}$
Input to drain charge;	$Q_{ID}$	–	10	16	nC	$I_{SL} = 3 \text{ A}$ ; $V_S = 14 \text{ V}$
Input charge total;	$Q_I$	–	28	43	nC	$I_{SL} = 3 \text{ A}$ ; $V_S = 14 \text{ V}$ $V_{IL} = 0 \text{ to } 10 \text{ V}$
Input plateau voltage;	$V_{(\text{plateau})}$	–	2.75	-	V	$I_{SL} = 3 \text{ A}$ ; $V_S = 14 \text{ V}$

*Note: switching times and input charges are guaranteed by design*

#### Control Inputs of highside switches IH 1, 2

H-input voltage	$V_{IH \text{ High}}$	–	–	2.5	V	–
L-input voltage	$V_{IH \text{ Low}}$	1	–	–	V	–
Input voltage hysteresis	$V_{IH \text{ HY}}$	–	0.3	–	V	–
H-input current	$I_{IH \text{ High}}$	15	30	60	$\mu\text{A}$	$V_{GH} = 5 \text{ V}$
L-input current	$I_{IH \text{ Low}}$	5	–	20	$\mu\text{A}$	$V_{GH} = 0.4 \text{ V}$
Input series resistance	$R_I$	2.7	4	5.5	$\text{k}\Omega$	–
Zener limit voltage	$V_{IH \text{ Z}}$	5.4	–	–	V	$I_{GH} = 1.6 \text{ mA}$

#### Control Inputs IL1, 2

Gate-threshold-voltage	$V_{IL \text{ th}}$	0.9	1.7	2.2	V	$I_{DL} = 1 \text{ mA}$
------------------------	---------------------	-----	-----	-----	---	-------------------------

*Note: The listed characteristics are ensured over the operating range of the integrated circuit. Typical characteristics specify mean values expected over the production spread. If not otherwise specified, typical characteristics apply at  $T_A = 25 \text{ }^\circ\text{C}$  and the given supply voltage.*

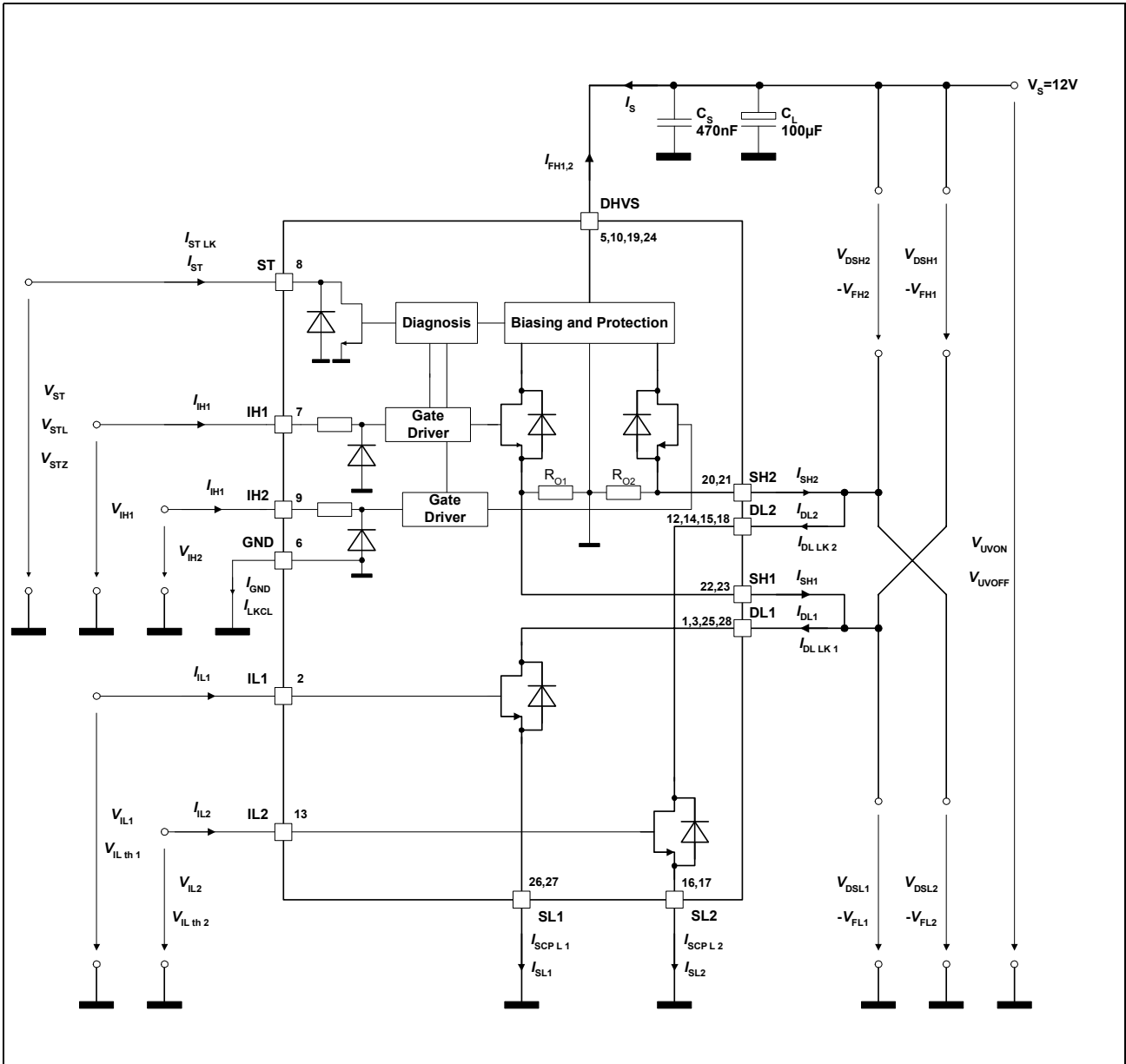
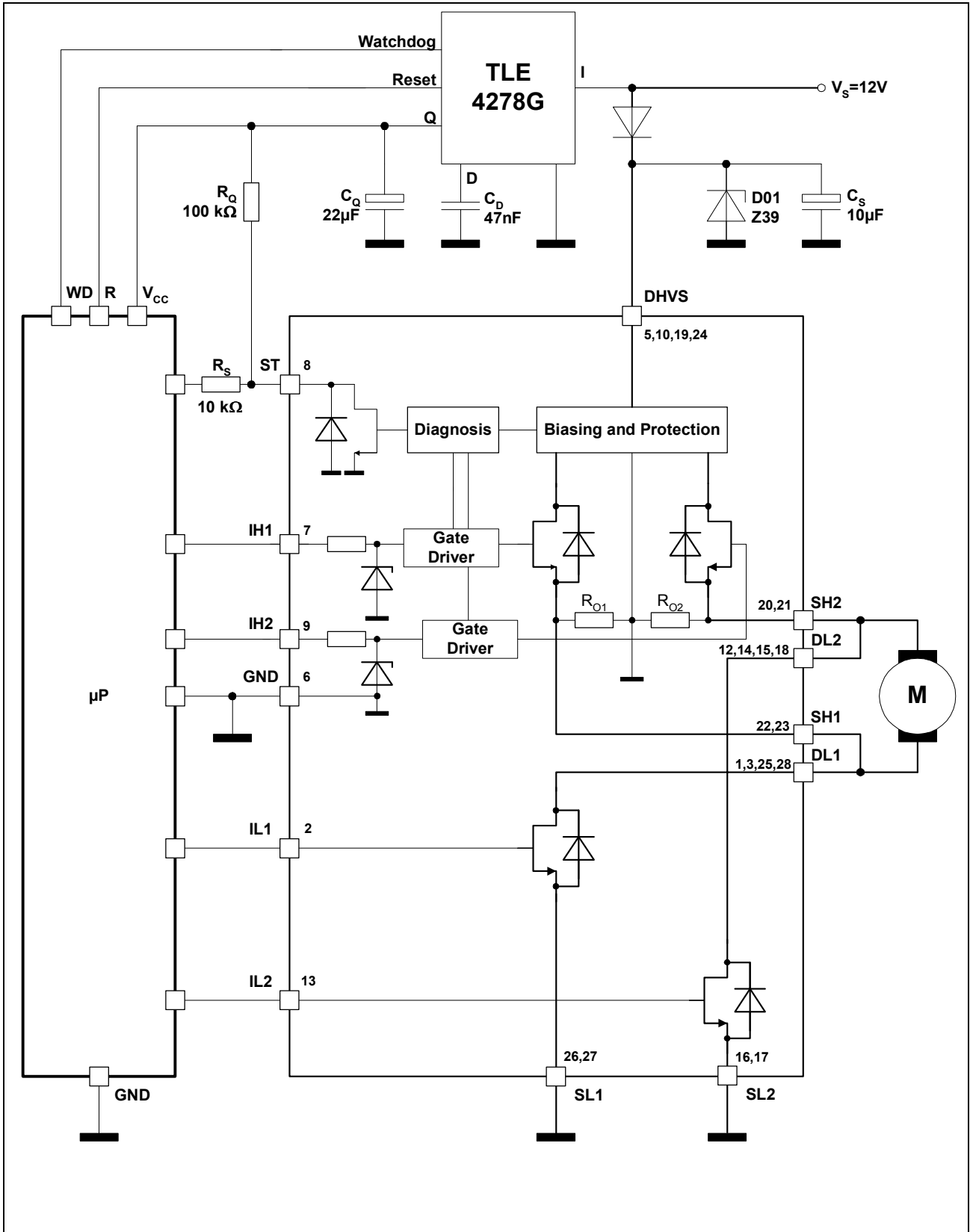

Figure 3  
Test Circuit

HS-Source-Current	Named during Short Circuit	Named during Leakage-Cond.
$I_{SH1,2}$	$I_{SCP H}$	$I_{DL LK}$



**Figure 4**  
**Application Circuit**

**4 Package Outlines**

**P-DSO-28-14**  
(Plastic Transistor Single Outline Package)

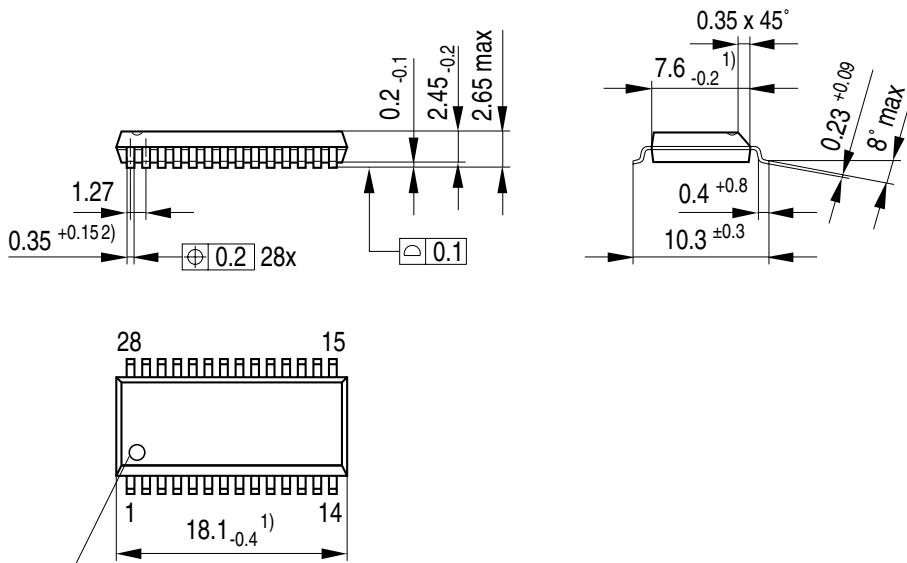

Index Marking

- 1) Does not include plastic or metal protrusions of 0.15 max per side
- 2) Does not include dambar protrusion of 0.05 max per side

GPS05123

GPS05123

**Sorts of Packing**

Package outlines for tubes, trays etc. are contained in our Data Book "Package Information".

**SMD = Surface Mounted Device**

Dimensions in mm





**Published by**  
**Infineon Technologies AG i Gr.,**  
**Bereichs Kommunikation**  
**St.-Martin-Strasse 53,**  
**D-81541 München**  
**© Infineon Technologies AG 1999**  
**All Rights Reserved.**

**Attention please!**

The information herein is given to describe certain components and shall not be considered as warranted characteristics.

Terms of delivery and rights to technical change reserved.

We hereby disclaim any and all warranties, including but not limited to warranties of non-infringement, regarding circuits, descriptions and charts stated herein.

Infineon Technologies is an approved CECC manufacturer.

**Information**

For further information on technology, delivery terms and conditions and prices please contact your nearest Infineon Technologies Office in Germany or our Infineon Technologies Representatives worldwide (see address list).

**Warnings**

Due to technical requirements components may contain dangerous substances. For information on the types in question please contact your nearest Infineon Technologies Office.

Infineon Technologies Components may only be used in life-support devices or systems with the express written approval of Infineon Technologies, if a failure of such components can reasonably be expected to cause the failure of that life-support device or system, or to affect the safety or effectiveness of that device or system. Life support devices or systems are intended to be implanted in the human body, or to support and/or maintain and sustain and/or protect human life. If they fail, it is reasonable to assume that the health of the user or other persons may be endangered.