

Excellent Integrated System Limited

Stocking Distributor

Click to view price, real time Inventory, Delivery & Lifecycle Information:

[Molex Connector Corporation](#)
[0639112300](#)

For any questions, you can email us directly:

sales@integrated-circuit.com

T2 Terminator for 3.96 (.156") Wire-to-Wire and Wire-to-Board Crimp Terminal

T2 Terminator Tooling		
	Application Tooling Specification Sheet	
		Order No. 63911-2300

FEATURES

- It is ideally suited for mid-volume bench operations
- This terminator can be installed in the TM42 and the TM40 press or Base Unit adapter for 3BF press
- Quick punch removal with the push of a button for fast and easy tooling change
- Track adjustment capabilities in the T2 Terminators for improved control of the bell mouth size and cutoff tab length
- T2 Terminator has standardized tooling with the Molex FineAdjust Applicator which will reduce your inventory requirements

SCOPE

Products: 3.96 (.156") Wire-to-Wire and Wire-to-Board Crimp Terminal, 16-22 AWG.

Terminal Series No.	Terminal Order No.	Wire Size and Type		Insulation Diameter				Strip Length	
				IPC/WHMA-A620 (1)		Terminal (2)			
		AWG	Type	mm	In.	mm	In.	mm	In.
50597	50597-8000	16-22	UL 1015	2.40-3.30	.094-.129	2.40-3.30	.094-.129	2.70-3.30	.106-.130
		16-18	UL 1007	2.00-2.50	.079-.098	2.00-2.50	.079-.098		
50599	50599-8000	16-22	UL 1015	2.40-3.30	.094-.129	2.40-3.30	.094-.129	2.70-3.30	.106-.130
		16-18	UL 1007	2.00-2.50	.079-.098	2.00-2.50	.079-.098		

(1) To achieve optimum IPC-A620 Class 2 insulation crimps, use this insulation OD range
 (2) Overall insulation OD specification for terminal

DEFINITION OF TERMS

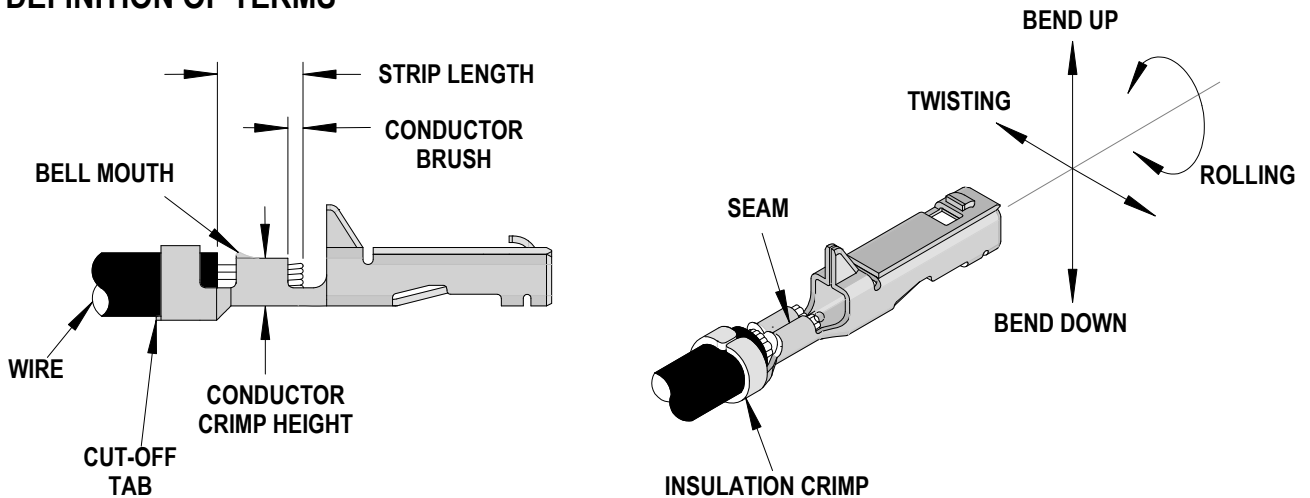

T2 Terminator for 3.96 (.156") Wire-to-Wire and Wire-to-Board Crimp Terminal

CRIMP SPECIFICATION

Terminal Series No.	Bell mouth		Cut-off Tab Maximum		Conductor Brush	
	mm	In.	mm	In.	mm	In.
50597	0.10-0.60	.004-.024	0.25	.010	0.00-1.00	.000-.039
50599	0.10-0.60	.004-.024	0.25	.010	0.00-1.00	.000-.039

Terminal Series No.	Bend up	Bend down	Twist	Roll	Punch Width mm (Ref)				Seam Seam shall not be open and no wire allowed out of the crimping area
	Degree				Degree		Conductor		
					mm	In	mm	In	
50597	4	3	3	8	2.00	.078	3.00	.118	
50599	4	3	3	8	2.00	.078	3.00	.118	

After crimping, the crimp profiles should measure the following:

Terminal Series No.	Wire Size and Type		Conductor Crimp Height		Insulation Crimp Height (Ref)		Pull Force Minimum	
	AWG	Type	mm	In.	mm	In.	N	Lb.
50597	16 AWG	UL 1015	1.21-1.31	.047-.052	3.80	.150	127.40	28.6
	18 AWG	UL 1015	1.16-1.26	.045-.050	3.70	.146	88.20	19.8
	20 AWG	UL 1015	1.02-1.12	.040-.044	3.65	.144	58.80	13.2
	22 AWG	UL 1015	0.97-1.02	.038-.040	3.50	.138	39.20	8.8
	16 AWG	UL 1007	1.21-1.31	.047-.052	3.70	.146	127.40	28.6
	18 AWG	UL 1007	1.16-1.26	.045-.050	3.30	.130	88.20	19.8
50599	16 AWG	UL 1015	1.21-1.31	.047-.052	3.80	.150	127.40	28.6
	18 AWG	UL 1015	1.16-1.26	.045-.050	3.70	.146	88.20	19.8
	20 AWG	UL 1015	1.02-1.12	.040-.044	3.65	.144	58.80	13.2
	22 AWG	UL 1015	0.97-1.02	.038-.040	3.50	.138	39.20	8.8
	16 AWG	UL 1007	1.21-1.31	.047-.052	3.70	.146	127.40	28.6
	18 AWG	UL 1007	1.16-1.26	.045-.050	3.30	.130	88.20	19.8

Tool Qualification Notes:

1. Pull Force should be measured with no influence from the insulation crimp.
2. The above specifications are guidelines to an optimum crimp.

T2 Terminator for 3.96 (.156") Wire-to-Wire and Wire-to-Board Crimp Terminal

PARTS LIST

Terminator 63911-2300				
Item	Order No	Engineering No.	Description	Quantity
Perishable Tooling				
	63911-2370	63911-2370	Tool Kit (All "Y" Items)	REF
1	63444-2005	63444-2005	Conductor Punch	1 Y
2	63445-2019	63445-2019	Conductor Anvil	1 Y
3	63446-3018	63446-3018	Insulation Punch	1 Y
4	63445-3033	63445-3033	Insulation Anvil	1 Y
5	63443-0005	63443-0005	Cut-Off Plunger	1 Y
6	63443-0012	63443-0012	Front Plunger Retainer	1 Y
Other Components				
7	11-17-0022	1739-21	Hold Down Spring	1
8	11-18-4083	60707-8	Feed Guide	1
9	11-24-1067	4996-4	Cut-off Plunger Spring	1
10	63443-0009	63443-0009	Front Scrape Chute	1
11	63443-0024	63443-0024	Key	1
12	63443-0085	63443-0085	Wire Stop L-Bracket	1
13	63443-0090	63443-0090	Wire Stop	1
14	63443-0093	63443-0093	Shank	1
15	63443-1719	63443-1719	Height Spacer	1
16	63443-2216	63443-2216	Coarse Spacer (16.00mm)	1
17	63443-2301	63443-2301	Fine Spacer (3.05mm)	1
18	63443-2802	63443-2802	Front Plunger Striker	1
19	63443-2910	63443-2910	Wire Hold Down Plunger	1
20	63443-6007	63443-6007	Rear Cover	1
21	63443-7201	63443-7201	Spring Cover	1
22	63600-1057	63600-1057	Compression Spring	1
23	63600-2972	63600-2972	Collar	2
24	63901-9802	63901-9802	Terminal Hold Down	1
Frame				
25	63800-8500	63800-8500	T2 Terminator	1
Hardware				
26	N/A	N/A	M3 by 6 Long SHCS	2**
27	N/A	N/A	M3 by 6 Long FHCS	1**
28	N/A	N/A	M3 by 8 Long SHCS	1**
29	N/A	N/A	M4 by 6 Long SHCS	2**
30	N/A	N/A	M4 by 12 Long BHCS	2**
31	N/A	N/A	M4 by 14 Long SHCS	2**
32	N/A	N/A	M4 by 30 Long SHCS	2**
33	N/A	N/A	M4 by 50 Long SHCS	2**
34	N/A	N/A	M5 by 12 Long SHCS	1**
35	N/A	N/A	#10-32 by 3/8" Long BHCS	1**
** Available from an industrial supply company such as MSC (1-800-645-7270).				

T2 Terminator for 3.96 (.156") Wire-to-Wire and Wire-to-Board Crimp Terminal

Assembly Drawing

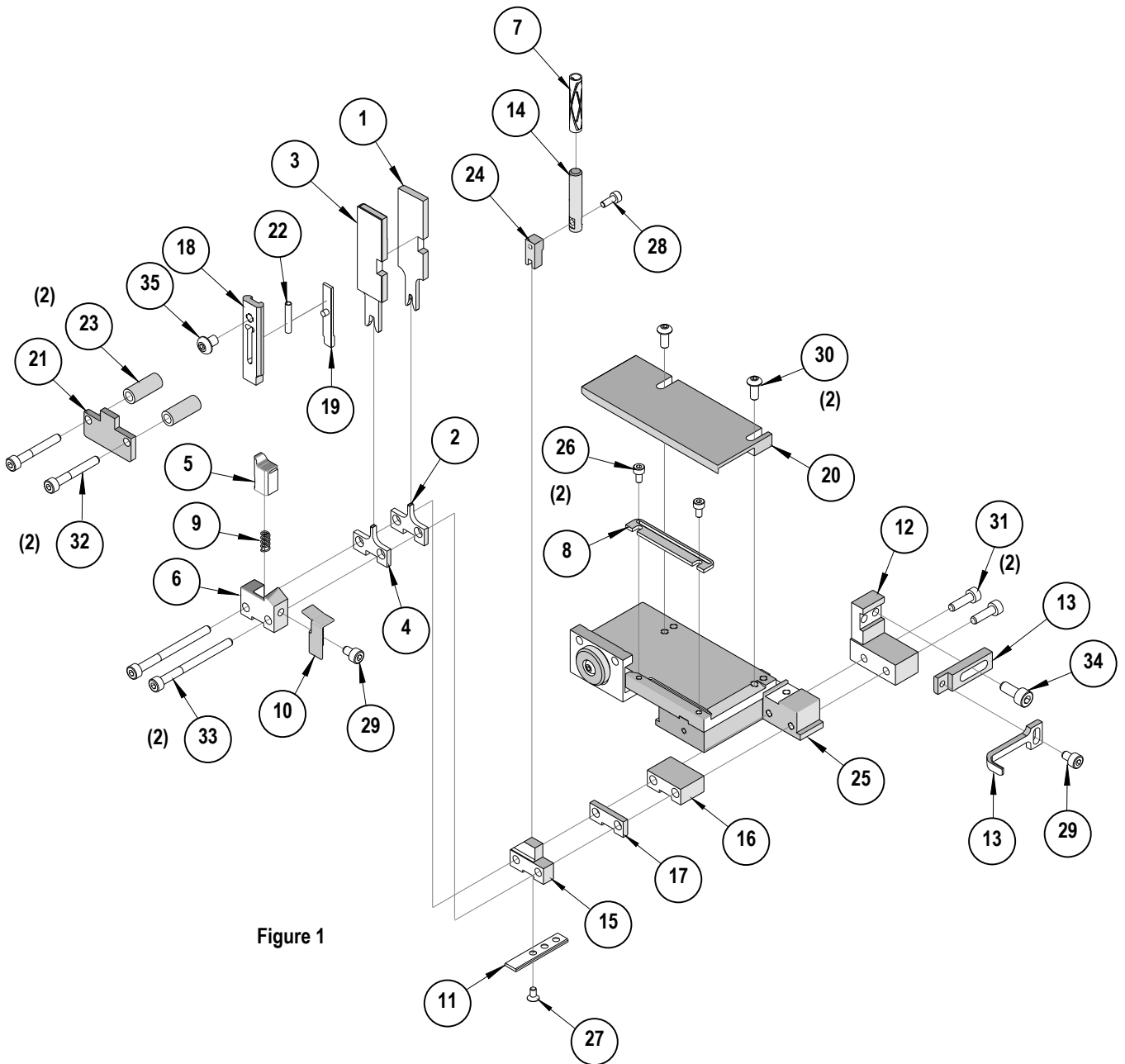

Figure 1

T2 Terminator for 3.96 (.156") Wire-to-Wire and Wire-to-Board Crimp Terminal

NOTES

Depending on the press vintage a feed finger assembly is supplied with the T2 Terminator.

1. To remove the existing feed finger assembly loosens the M4 x 10 mm set screw in the feed lever.
2. Select T2 Feed finger assembly from Terminator box.
3. Insert a screwdriver into the slot behind the feed lever and force the feed arm spring to the right.
4. Slide the T2 feed finger shaft for TM42 (11-40-5307) or (11-40-0123) for TM40 /Base Unit into the feed lever and to the left of the feed arm spring.
5. Release the feed arm spring.
6. Position feed finger for selected product. (Refer to Figure 5.1 in the T2 Manual).

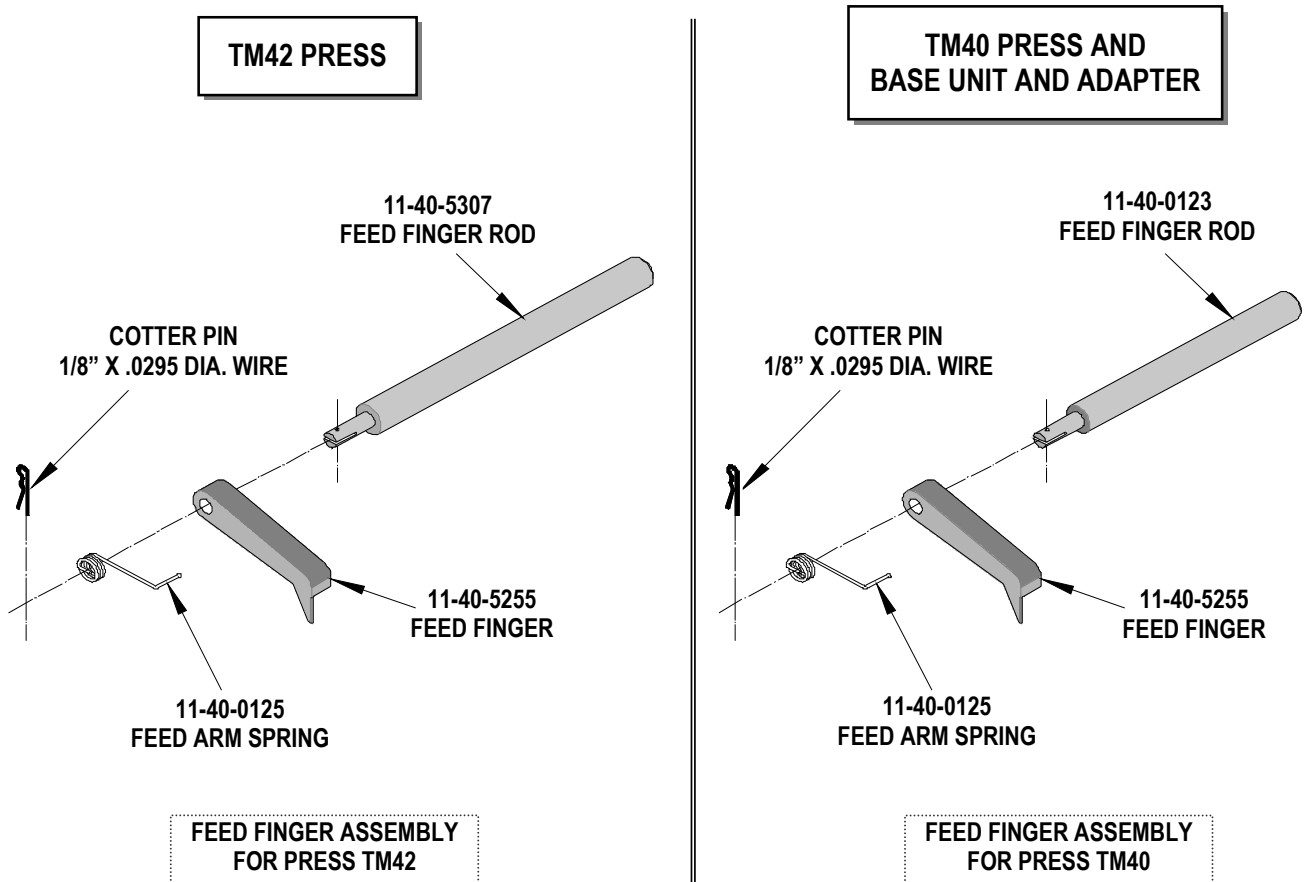

Figure 2

T2 Terminator for 3.96 (.156") Wire-to-Wire and Wire-to-Board Crimp Terminal

NOTES

1. Molex recommends an extra perishable tooling kit be maintained at your facility.
2. Verify tooling alignment by manually cycling the press before crimping under power. Check that all screws are tight.
3. Slugs, Terminals, Dirt and Oil should be kept clear of work area.
4. This Terminator should be only used in a Molex TM42, TM40, or 3BF Press with a Base Unit adaptor.
5. Wear safety glasses at all times.
6. For recommended maintenance refer to the TM40, TM42 Manual.

CAUTION: To prevent injury never operate this Terminator without the guards supplied with the press or in place. Reference the TM42 press manufacturer's instruction manual.

CAUTION: Molex crimp specifications are valid only when used with Molex terminals, terminator s and tooling.

<http://www.molex.com>