

Excellent Integrated System Limited

Stocking Distributor

Click to view price, real time Inventory, Delivery & Lifecycle Information:

[Molex Connector Corporation](#)
[0690011000](#)

For any questions, you can email us directly:

sales@integrated-circuit.com



OBSOLETE

APPLICATOR No. 69001-1000

PRODUCT No. 90020/21 - 01XX

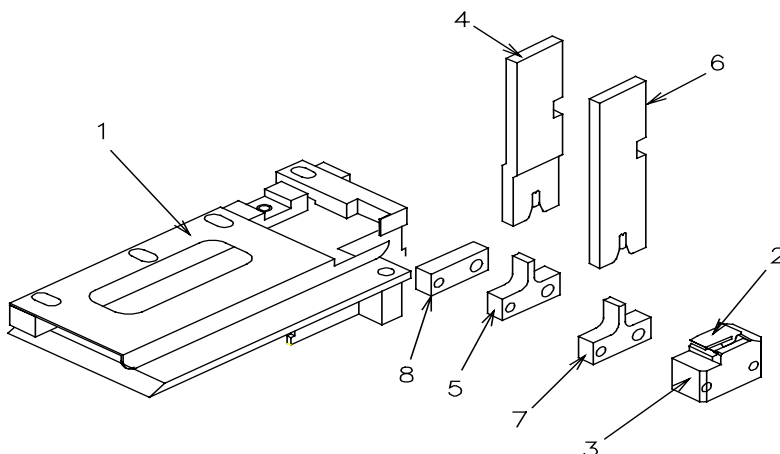

FEED FINGER: 90020-01XX USE 69001-0105, 90021-01XX USE 69001-0106

ITEM	PART NUMBER	DESCRIPTION
1	69001-0000	BASE MODULE (UNTOOLED)
2	69001-0060	SHEAR PUNCH
3	69001-0075	SHEAR DIE
4	69001-0041	CONDUCTOR PUNCH
5	69001-0040	CONDUCTOR ANVIL
6	69001-0021	INSULATION PUNCH
7	69001-0019	INSULATION ANVIL
8	69001-0017	SPACER
9	69001-2001	TOOL KIT (ITEMS 4 - 7)

CRIMP SPECIFICATION: (SEE ALSO PRODUCT SPEC.)

WIRE mm ² (AWG)	CRIMP HEIGHT (COND)	PULL FORCE (MIN)
0.5 (20)	1.28/1.33mm (.050"/.052")	8.2kg (18 lbs)
0.72 (-)	1.36/1.41mm (.053"/.055")	13.2kg (29 lbs)
1.0 (17)	1.43/1.48mm (.056"/.058")	16.3kg (36 lbs)
1.5 (-)	1.47/1.52mm (.058"/.060")	20.9kg (46 lbs)

WIRE STRIP LENGTH: - 3.5/4.0 mm (.138"/.157")