



Distributor of Texas Instruments: Excellent Integrated System Limited

Datasheet of SN75116N - IC DIFF LINE TRANS 16-DIP

Contact us: sales@integrated-circuit.com Website: www.integrated-circuit.com

Excellent Integrated System Limited

Stocking Distributor

Click to view price, real time Inventory, Delivery & Lifecycle Information:

[Texas Instruments](#)
[SN75116N](#)

For any questions, you can email us directly:

sales@integrated-circuit.com

SN55116, SN75116, SN75117, SN75118, SN75119 DIFFERENTIAL LINE TRANSCEIVERS

SLLS073D – MAY 1976 – REVISED MAY 1998

features common to all types

- Single 5-V Supply
- 3-State Driver Output Circuitry
- TTL-Compatible Driver Inputs
- TTL-Compatible Receiver Output
- Differential Line Operation
- Receiver Output Strobe (SN55116, SN75116, SN75117) or Enable (SN75118, SN75119)
- Designed for Party-Line (Data-Bus) Applications

additional features of the SN55116/SN75116

- Choice of Ceramic or Plastic Packages
- Independent Driver and Receiver
- Choice of Open-Collector or Totem-Pole Outputs on Both Driver and Receiver
- Dual Data Inputs on Driver
- Optional Line-Termination Resistor in Receiver
- ± 15 -V Receiver Common-Mode Capability
- Receiver Frequency-Response Control

additional features of the SN75117

- Driver Output Internally Connected to Receiver Input

The SN75118 is an SN75116 With 3-State Receiver Output Circuitry
The SN75119 is an SN75117 With 3-State Receiver Output Circuitry

description

These integrated circuits are designed for use in interfacing between TTL-type digital systems and differential data-transmission lines. They are especially useful for party-line (data-bus) applications. Each of these circuit types combine in one package a 3-state differential line driver and a differential-input line receiver, both of which operate from a single 5-V power supply. The driver inputs and the receiver outputs are TTL compatible. The driver employed is similar to the SN55113 and SN75113 3-state line drivers, and the receiver is similar to the SN55115 and SN75115 line receivers.

The SN55116, SN75116, and SN75118 offer all the features of the SN55113 and SN75113 drivers and the SN55115 and SN75115 receivers combined. The driver performs the dual input AND and NAND functions when enabled or presents a high impedance to the load when in the disabled state. The driver output stages are similar to TTL totem-pole outputs, but have the current-sinking portion separated from the current-sourcing portion and both are brought out to adjacent package terminals. This feature allows the user the option of using the driver in the open-collector output configuration, or, by connecting the adjacent source and sink terminals together, of using the driver in the normal totem-pole output configuration.

The receiver portion of the SN55116, SN75116, and SN75118 features a differential-input circuit having a common-mode voltage range of ± 15 V. An internal 130- Ω equivalent resistor also is provided, which optionally can be used to terminate the transmission line. A frequency-response control terminal allows the user to reduce the speed of the receiver or to improve differential noise immunity. The receivers of the SN55116 and SN75116 have an output strobe and a split totem-pole output. The receiver of the SN75118 has an output-enable for the 3-state split totem-pole output. The receiver section of either circuit is independent of the driver section except for the V_{CC} and ground terminals.

The SN75117 and SN75119 provide the basic driver and receiver functions of the SN55116, SN75116, and SN75118, but use a package that is only half as large. The SN75117 and SN75119 are intended primarily for party-line or bus-organized systems because the driver outputs are internally connected to the receiver inputs. The driver has a single data input and a single enable input. The SN75117 receiver has an output strobe, while the SN75119 receiver has a 3-state output enable. However, these devices do not provide output connection options, line-termination resistors, or receiver frequency-response controls.



Please be aware that an important notice concerning availability, standard warranty, and use in critical applications of Texas Instruments semiconductor products and disclaimers thereto appears at the end of this data sheet.

PRODUCTION DATA information is current as of publication date. Products conform to specifications per the terms of Texas Instruments standard warranty. Production processing does not necessarily include testing of all parameters.

Copyright © 1998, Texas Instruments Incorporated



POST OFFICE BOX 655303 • DALLAS, TEXAS 75265
 POST OFFICE BOX 1443 • HOUSTON, TEXAS 77251-1443

**SN55116, SN75116, SN75117, SN75118, SN75119
DIFFERENTIAL LINE TRANSCEIVERS**

SLLS073D – MAY 1976 – REVISED MAY 1998

description (continued)

The SN55116 is characterized for operation over the full military temperature range of -55°C to 125°C. The SN75116, SN75117, SN75118, and SN75119 are characterized for operation from 0°C to 70°C.

**SN55116 . . . J PACKAGE
SN75116 . . . D OR N PACKAGE
(TOP VIEW)**

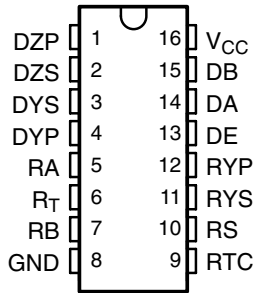

**SN55116 . . . FK PACKAGE
(TOP VIEW)**

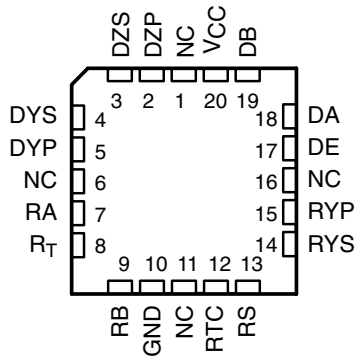

NC – No internal connection

**SN75118 . . . D OR N PACKAGE
(TOP VIEW)**

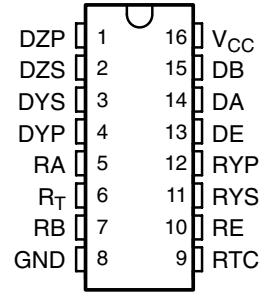

**SN75117 . . . D OR P PACKAGE
(TOP VIEW)**

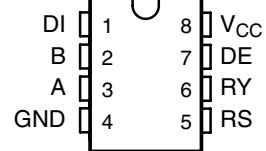

**SN75119 . . . D OR P PACKAGE
(TOP VIEW)**

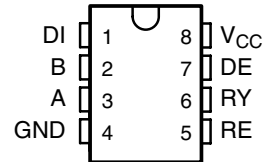

Function Tables

**'116, SN75118
DRIVER**

| INPUTS | | | OUTPUTS | |
|--------|----|----|---------|----|
| DE | DA | DB | DY | DZ |
| L | X | X | Z | Z |
| H | L | X | L | H |
| H | X | L | L | H |
| H | H | H | H | L |

**'116, SN75118
RECEIVER**

| RS/RE | DIFF INPUT | OUTPUTS RY | |
|-------|------------|------------|---------|
| | | '116 | SN75118 |
| L | X | H | Z |
| H | L | H | H |
| H | H | L | L |

**SN75117, SN75119
DRIVER**

| INPUTS | | OUTPUTS | |
|--------|----|---------|---|
| DI | DE | A | B |
| H | H | H | L |
| L | H | L | H |
| X | L | Z | Z |

**SN75117, SN75119
RECEIVER**

| INPUTS | | | OUTPUT RY | |
|--------|---|-------|-----------|---------|
| A | B | RS/RE | SN75117 | SN75119 |
| H | L | H | H | H |
| L | H | H | L | L |
| X | X | L | H | Z |

H = high level ($V_1 \geq V_{IH}$ min or V_{ID} more positive than V_{TH} max), L = low level ($V_1 \leq V_{IL}$ max or V_{ID} more negative than V_{TL} max), X = irrelevant, Z = high impedance (off)

**SN55116, SN75116, SN75117, SN75118, SN75119
DIFFERENTIAL LINE TRANSCEIVERS**

SLLS073D - MAY 1976 - REVISED MAY 1998

logic symbol†

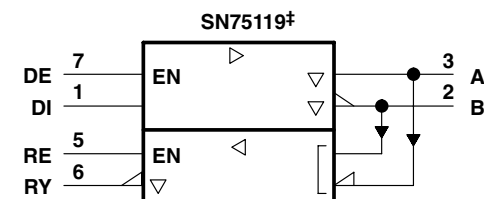
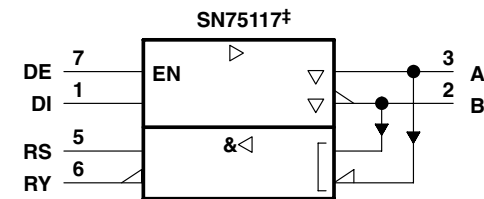
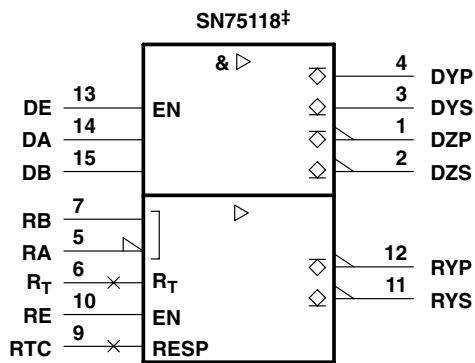
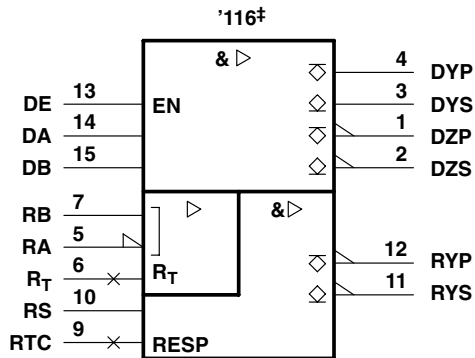

logic diagram (positive logic)

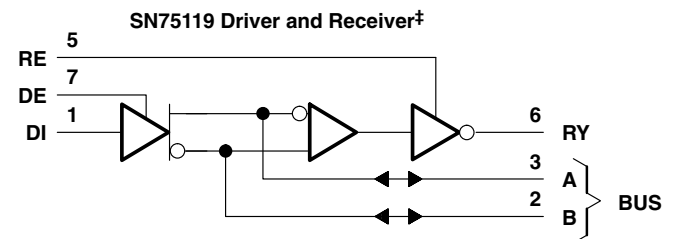
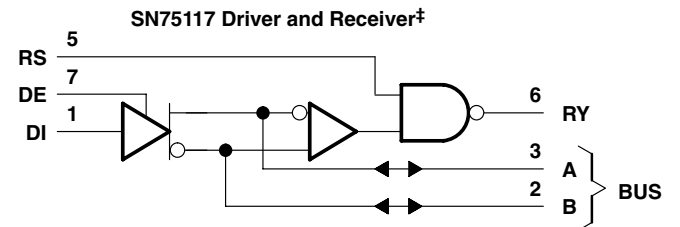
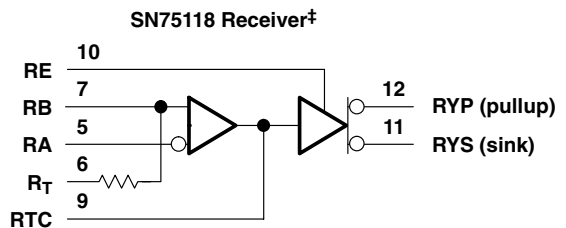
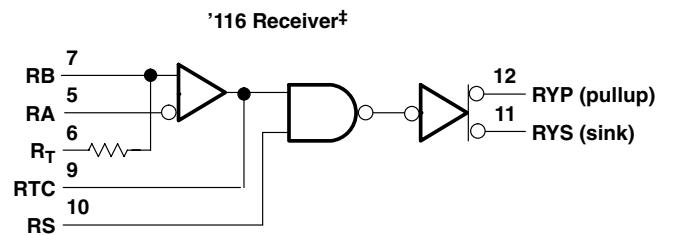
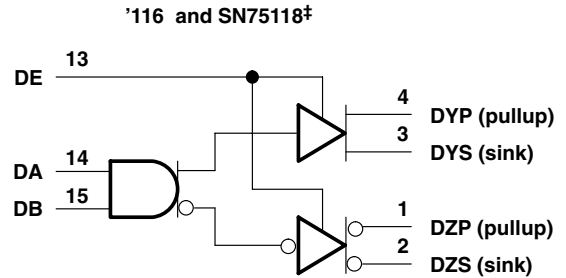

† These symbols are in accordance with ANSI/IEEE Std 91-1984 and IEC Publication 617-12.

‡ Pin numbers shown for the SN55116 and SN75116 are for the D, J, and N packages, those shown for the SN75118 are for the D and N packages, and those shown for SN75117 and SN75119 are for the D and P packages.

SN55116, SN75116, SN75117, SN75118, SN75119
DIFFERENTIAL LINE TRANSCEIVERS

SLLS073D – MAY 1976 – REVISED MAY 1998

schematics of inputs and outputs

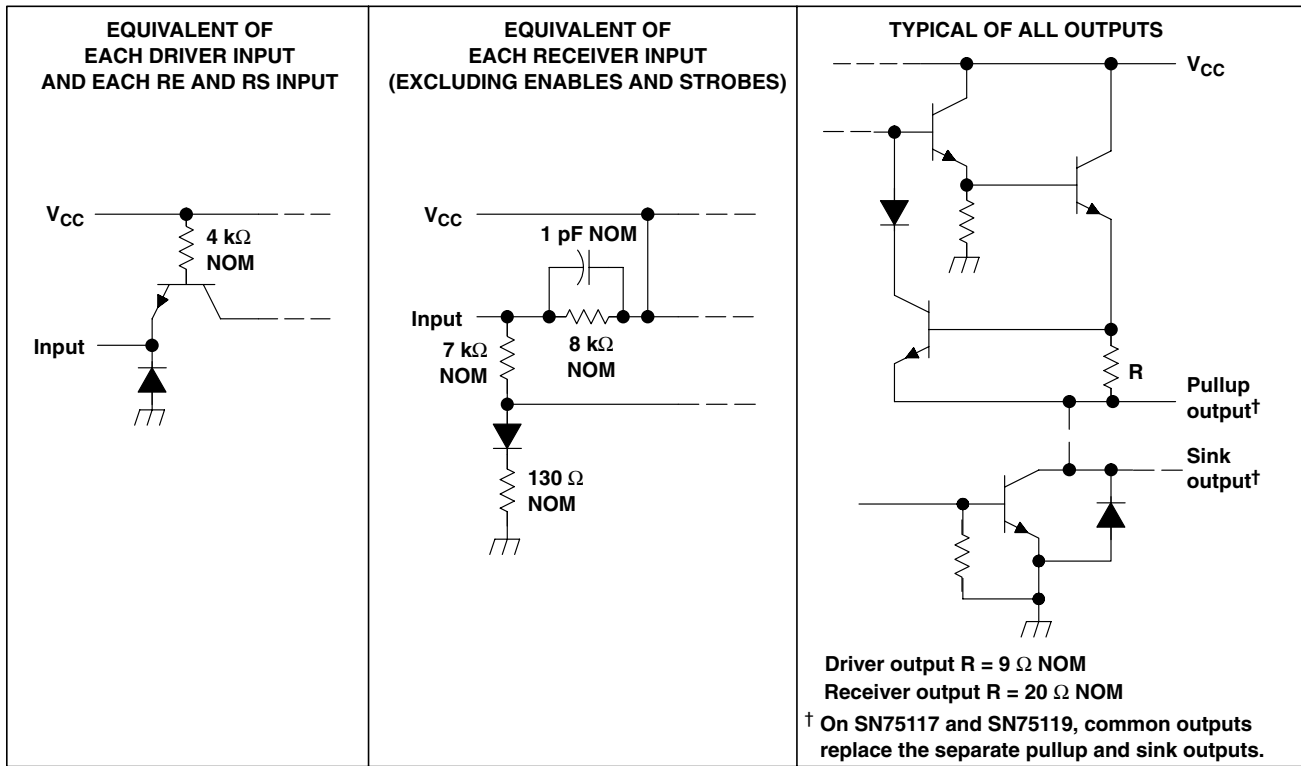

absolute maximum ratings over operating free-air temperature (unless otherwise noted)‡

| | |
|--|--|
| Supply voltage, V_{CC} (see Notes 1 and 2) | 7 V |
| Input voltage, V_I : DA, DB, DE, DI, RE, and RS | 5.5 V |
| RA, RB, R_T for '116, SN75118 only | ± 25 V |
| A and B for SN75117, SN75119 only | 0 to 6 V |
| Off-state voltage applied to open-collector outputs: '116, SN75118 only | 12 V |
| Continuous total power dissipation (see Note 2) | See Dissipation Rating Table |
| Storage temperature range, T_{stg} | -65°C to 150°C |
| Case temperature for 60 seconds, T_C : FK package | 260°C |
| Lead temperature 1,6 mm (1/16 inch) from case for 60 seconds: J package | 300°C |
| Lead temperature 1,6 mm (1/16 inch) from case for 10 seconds: D, N, or P package | 260°C |

‡ Stresses beyond those listed under "absolute maximum ratings" may cause permanent damage to the device. These are stress ratings only, and functional operation of the device at these or any other conditions beyond those indicated under "recommended operating conditions" is not implied. Exposure to absolute-maximum-rated conditions for extended periods may affect device reliability.

- NOTES: 1. All voltage values are with respect to the network ground terminal.
 2. In the FK and J packages, the SN55116 chip is alloy mounted. The SN75116, SN75117, SN75118, and SN75119 chips are glass mounted.

**SN55116, SN75116, SN75117, SN75118, SN75119
DIFFERENTIAL LINE TRANSCEIVERS**

SLLS073D – MAY 1976 – REVISED MAY 1998

DISSIPATION RATING TABLE

| PACKAGE | T _A ≤ 25°C POWER RATING | DERATING FACTOR ABOVE T _A = 25°C | T _A = 70°C POWER RATING | T _A = 125°C POWER RATING |
|------------|---------------------------------------|--|---------------------------------------|--|
| D (8 pin) | 725 mW | 5.8 mW/°C | 464 mW | — |
| D (16 pin) | 950 mW | 7.6 mW/°C | 608 mW | — |
| FK | 1375 mW | 11.0 mW/°C | 880 mW | 275 mW |
| J | 1375 mW | 11.0 mW/°C | 880 mW | 275 mW |
| N | 1150 mW | 9.2 mW/°C | 736 mW | — |
| P | 1000 mW | 8.0 mW/°C | 640 mW | — |

recommended operating conditions

| PARAMETER | SN55116 | | | SN75116, SN75117, SN75118, SN75119 | | | UNIT |
|--|---------------------------------------|-----|-----|---------------------------------------|-----|-----|------|
| | MIN | NOM | MAX | MIN | NOM | MAX | |
| Supply voltage, V _{CC} | 4.5 | 5 | 5.5 | 4.5 | 5 | 5.5 | V |
| High-level input voltage, V _{IH} | All inputs except differential inputs | | | 2 | | | V |
| Low-level input voltage, V _{IL} | | | | 0.8 | | | V |
| High-level output current, I _{OH} | Drivers | | | -40 | | | mA |
| | Receivers | | | -5 | | | |
| Low-level output current, I _{OL} | Drivers | | | 40 | | | mA |
| | Receivers | | | 15 | | | |
| Receiver input voltage, V _I | '116, SN75118 | | | ±15 | | | V |
| | SN75117, SN75119 | | | 0 6 | | | |
| Common-mode receiver input voltage, V _{ICR} | '116, SN75118 | | | ±15 | | | V |
| | SN75117, SN75119 | | | 0 6 | | | |
| Operating free-air temperature, T _A | -55 | | | 125 | | | °C |

**SN55116, SN75116, SN75117, SN75118, SN75119
DIFFERENTIAL LINE TRANSCEIVERS**

SLLS073D – MAY 1976 – REVISED MAY 1998

switching characteristics, $V_{CC} = 5\text{ V}$, $C_L = 30\text{ pF}$, $T_A = 25^\circ\text{C}$

driver section

| PARAMETER | | TEST CONDITIONS | MIN | TYP | MAX | UNIT |
|-----------|--|-------------------------------------|-----|-----|-----|------|
| t_{PLH} | Propagation-delay time, low-to-high level output | See Figure 13 | | 14 | 30 | ns |
| t_{PHL} | Propagation-delay time, high-to-low level output | | | 12 | 30 | |
| t_{PZH} | Output-enable time to high level | $R_L = 180\ \Omega$, See Figure 14 | | 8 | 20 | ns |
| t_{PZL} | Output-enable time to low level | $R_L = 250\ \Omega$, See Figure 15 | | 17 | 40 | ns |
| t_{PHZ} | Output-disable time from high level | $R_L = 180\ \Omega$, See Figure 14 | | 16 | 30 | ns |
| t_{PLZ} | Output-disable time from low level | $R_L = 250\ \Omega$, See Figure 15 | | 20 | 35 | ns |

receiver section (continued)

| PARAMETER | | | TEST CONDITIONS† | | | '116, SN75118 | | | SN75117, SN75119 | | | UNIT |
|--------------|---|--------|---|---|--------------------------|---------------|----------|-----|------------------|----------|---------------|-------------|
| | | | | | | MIN | TYP‡ | MAX | MIN | TYP‡ | MAX | |
| I_{IH} | High-level input current | Enable | $V_{CC} = \text{MAX}$, $V_I = 2.4 \text{ V}$ | | SN75118, SN75119 | | 40 | | | 40 | μA | |
| I_I | Low-level input current | Strobe | $V_{CC} = \text{MAX}$, $V_{\text{strobe}} = 0.4 \text{ V}$, See Notes 4 and 7 | $V_{ID} = 0.5 \text{ V}$, See Notes 4 and 7 | '116, SN75117 | | -2.4 | | | -2.4 | mA | |
| | | Enable | $V_{CC} = \text{MAX}$, $V_I = 0.4 \text{ V}$ | | SN75118, SN75119 | | -1.6 | | | -1.6 | mA | |
| $I_{I(RTC)}$ | Response-time-control current (RTC) | | $V_{CC} = \text{MAX}$, RC at 0 V, | $V_{ID} = 0.5 \text{ V}$, See Notes 4 and 7 | $T_A = 25^\circ\text{C}$ | | -1.2 | | | | mA | |
| $I_{O(off)}$ | Off-state open-collector output current | | $V_{CC} = \text{MAX}$, $V_O = 12 \text{ V}$, $V_{ID} = -1 \text{ V}$ | $T_A = 25^\circ\text{C}$ | | | 1 | | 10 | | μA | |
| | | | | $T_A = \text{MAX}$ | SN55116 | | 200 | | | | | |
| I_{OZ} | Off-state (high-impedance-state) output current | | $V_{CC} = \text{MAX}$, $V_O = 0 \text{ to } V_{CC}$, RE at 0.4 V | $T_A = 25^\circ\text{C}$ | SN75116, SN75118 | | 20 | | | | μA | |
| | | | | $T_A = 25^\circ\text{C}$ | SN75118, SN75119 | | ± 10 | | | ± 10 | | |
| | | | | $T_A = \text{MAX}$ | SN75118 | | ± 20 | | | | | |
| I_{OZ} | | | | $T_A = \text{MAX}$ | SN75119 | | | | | ± 20 | μA | |
| | | | | | | | | | | | | |
| R_T | Line-terminating resistance | | $V_{CC} = 5 \text{ V}$ | | $T_A = 25^\circ\text{C}$ | | 77 | | 167 | | Ω | |
| I_{OS} | Short-circuit output current§ | | $V_{CC} = \text{MAX}$, $V_{ID} = -0.5 \text{ V}$, | $V_O = 0$, See Notes 4 and 6 | $T_A = 25^\circ\text{C}$ | | -15 | | -80 | -15 | -80 | mA |
| I_{CC} | Short current (driver and receiver combined) | | $V_{CC} = \text{MAX}$, See Notes 4 and 7 | $V_{ID} = 0.5 \text{ V}$, | $T_A = 25^\circ\text{C}$ | | 42 | | 60 | 42 | 60 | mA |

† Unless otherwise noted, $V_{\text{strobe}} = 2.4 \text{ V}$. All parameters, with the exception of off-state open-collector output current, are measured with the active pullup connected to the sink output. For conditions shown as MIN or MAX, use the appropriate value specified under recommended operating conditions.

‡ All typical values are at $V_{CC} = 5 \text{ V}$, $T_A = 25^\circ\text{C}$, and $V_{IC} = 0$.

§ Not more than one output should be shorted at a time.

NOTES: 4. This applies with the less positive receiver input grounded.

6. For SN55116, $V_{ID} = -1 \text{ V}$

7. For SN55116, $V_{ID} = 1 \text{ V}$

**SN55116, SN75116, SN75117, SN75118, SN75119
DIFFERENTIAL LINE TRANSCEIVERS**

SLLS073D – MAY 1976 – REVISED MAY 1998

switching characteristics, $V_{CC} = 5\text{ V}$, $C_L = 30\text{ pF}$, $T_A = 25^\circ\text{C}$

receiver section

| PARAMETER | | TEST CONDITIONS | MIN | TYP | MAX | UNIT |
|-----------|--|-------------------------------------|-----|-----|-----|------|
| t_{PLH} | Propagation-delay time, low-to-high-level output | $R_L = 400\ \Omega$, See Figure 16 | | 20 | 75 | ns |
| t_{PHL} | Propagation-delay time, high-to-low-level output | | | 17 | 75 | ns |
| t_{PZH} | Output-enable time to high level | $R_L = 480\ \Omega$, See Figure 14 | | 9 | 20 | ns |
| t_{PZL} | Output-enable time to low level | $R_L = 250\ \Omega$, See Figure 15 | | 16 | 35 | ns |
| t_{PHZ} | Output-disable time from high level | $R_L = 480\ \Omega$, See Figure 14 | | 12 | 30 | ns |
| t_{PLZ} | Output-disable time from low level | $R_L = 250\ \Omega$, See Figure 15 | | 17 | 35 | ns |

**SN55116, SN75116, SN75117, SN75118, SN75119
 DIFFERENTIAL LINE TRANSCEIVERS**

SLLS073D - MAY 1976 - REVISED MAY 1998

TYPICAL CHARACTERISTICS†

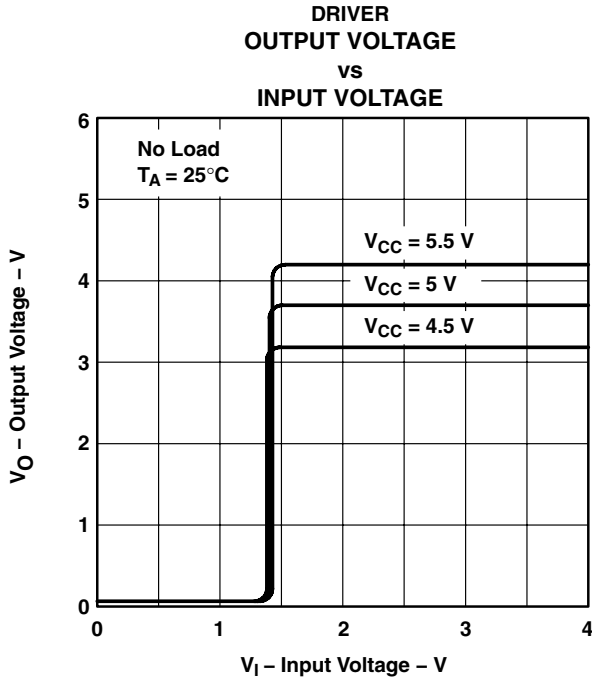

Figure 1

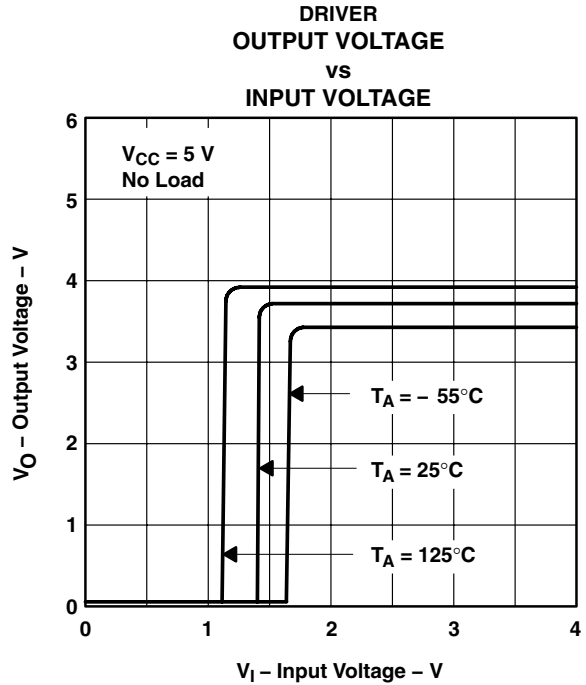

Figure 2

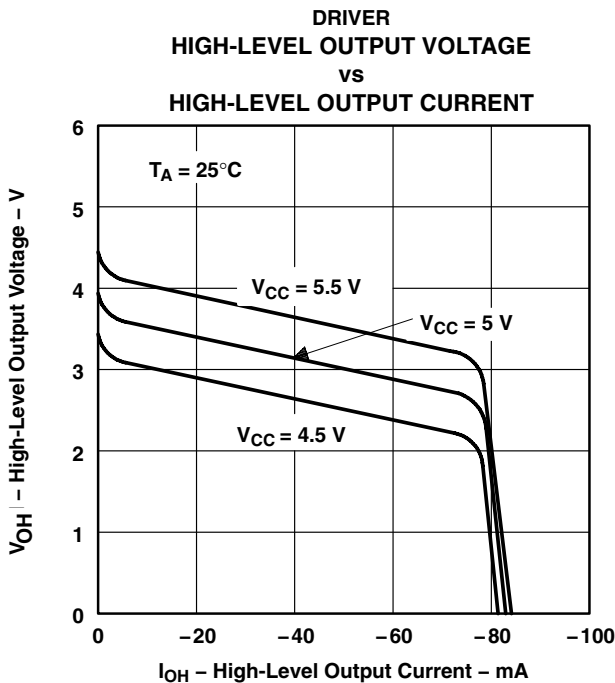

Figure 3

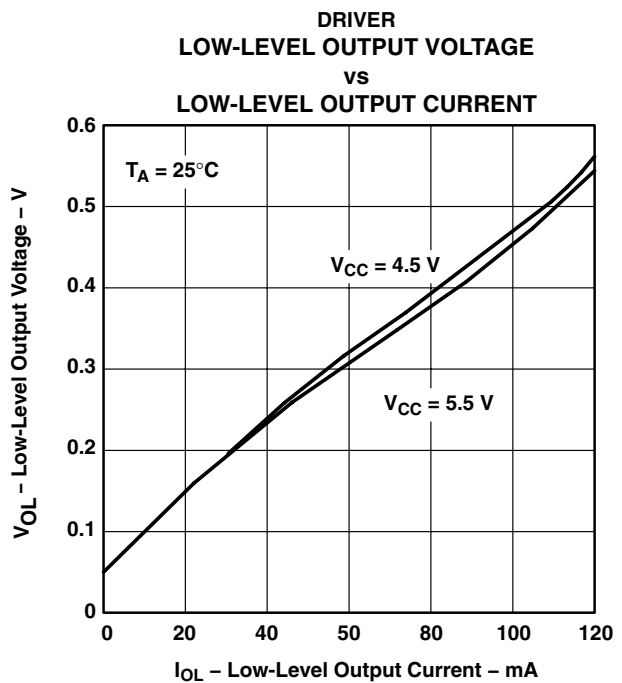

Figure 4

† Operation of the device at these or any other conditions beyond those indicated under "recommended operating conditions" is not implied.

**SN55116, SN75116, SN75117, SN75118, SN75119
DIFFERENTIAL LINE TRANSCEIVERS**

SLLS073D - MAY 1976 - REVISED MAY 1998

TYPICAL CHARACTERISTICS†

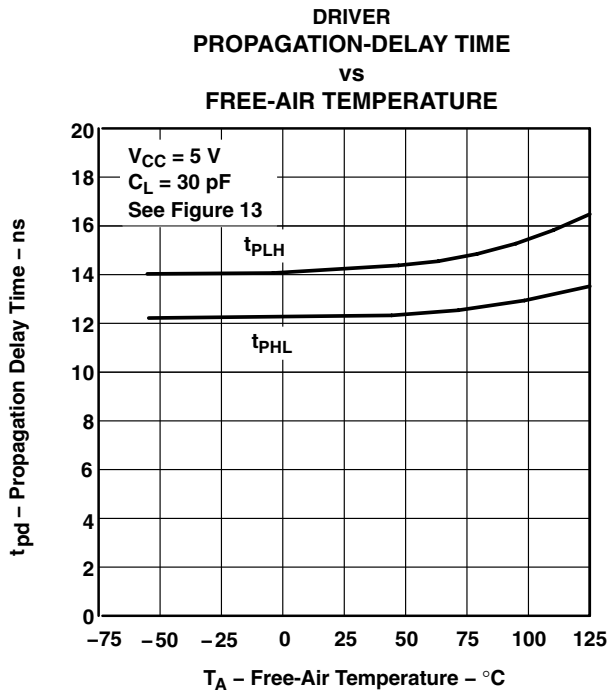
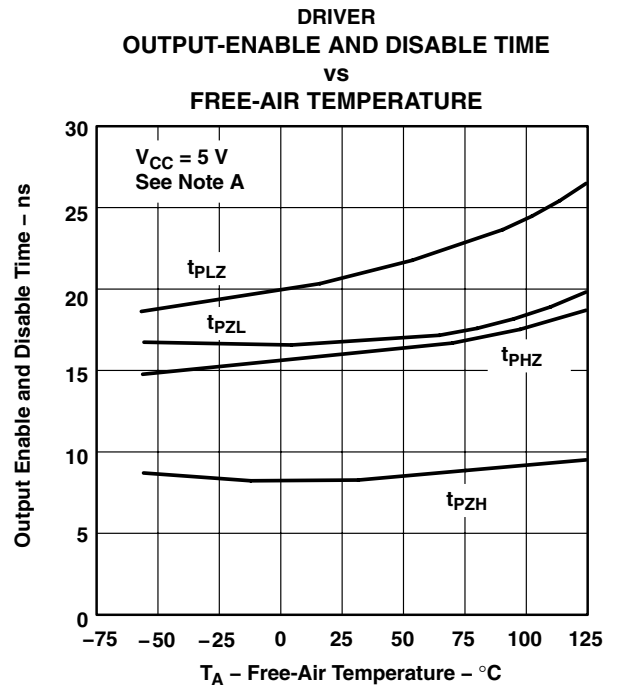

Figure 5



NOTE A: For t_{PZH} and t_{PHZ} : $R_L = 480 \Omega$, see Figure 14. For t_{PZL} and t_{PLZ} : $R_L = 250 \Omega$, see Figure 15.

Figure 6

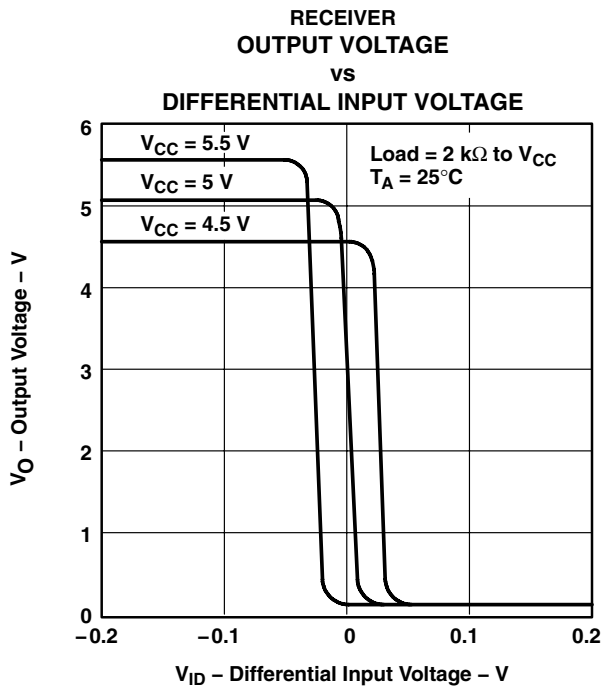

Figure 7

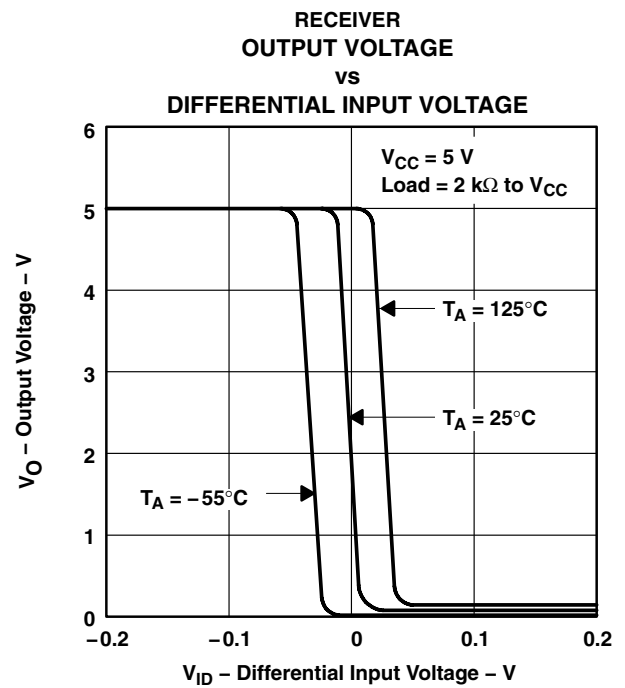

Figure 8

† Operation of the device at these or any other conditions beyond those indicated under "recommended operating conditions" is not implied.

**SN55116, SN75116, SN75117, SN75118, SN75119
DIFFERENTIAL LINE TRANSCEIVERS**

SLLS073D - MAY 1976 - REVISED MAY 1998

TYPICAL CHARACTERISTICS†

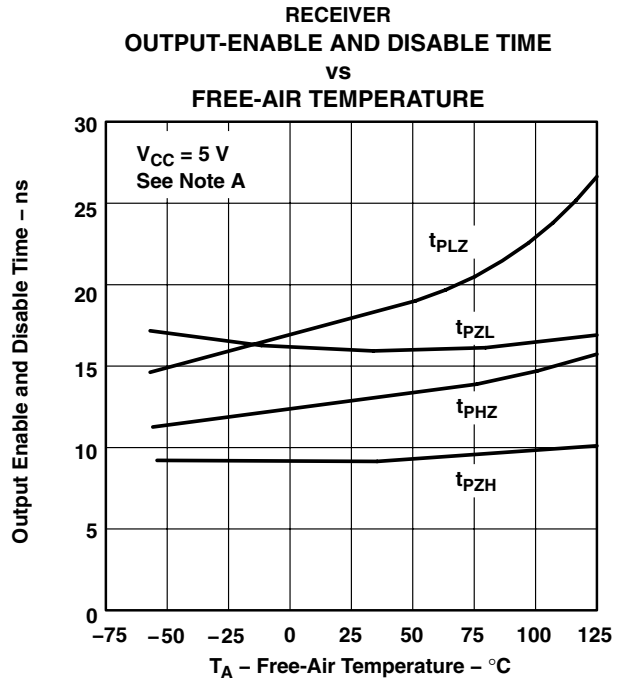
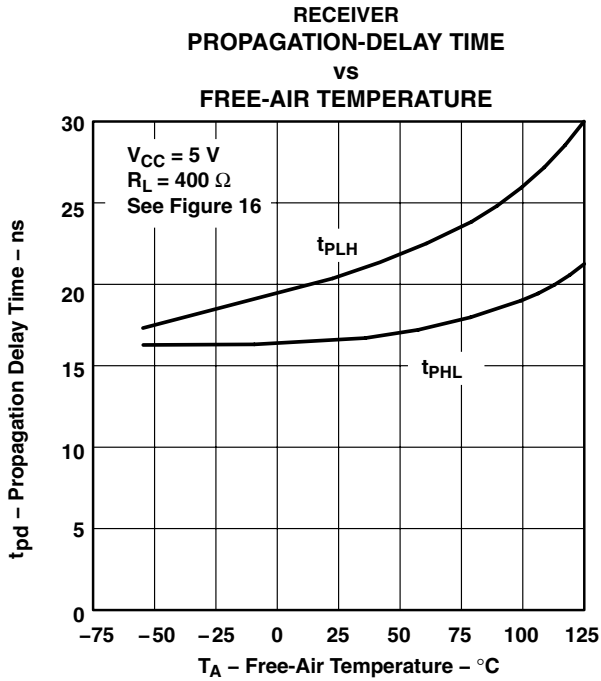

NOTE A: For tPZH and tPHZ: RL = 480 Ω, see Figure 14. For tPZL and tPLZ: RL = 250 Ω, see Figure 15.

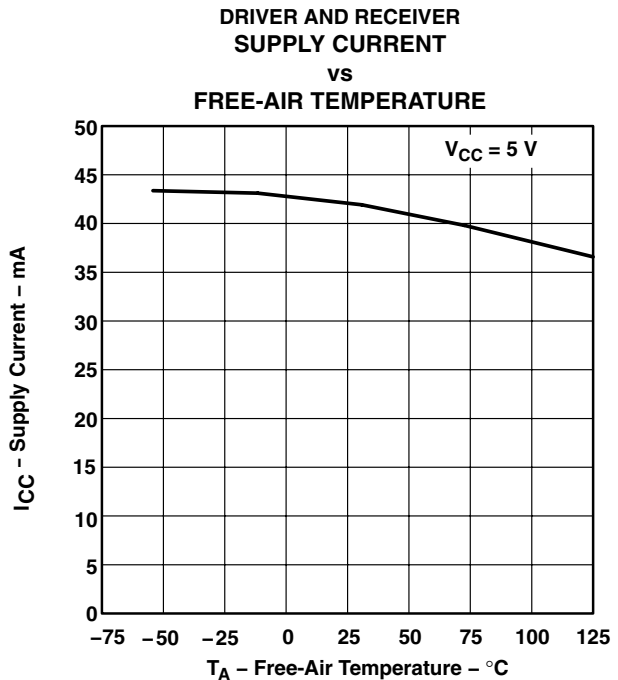
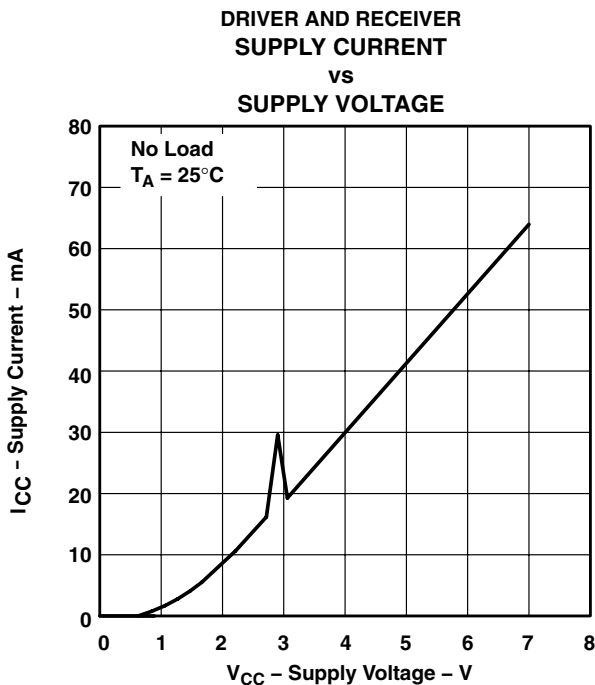

† Operation of the device at these or any other conditions beyond those indicated under "recommended operating conditions" is not implied.

**SN55116, SN75116, SN75117, SN75118, SN75119
DIFFERENTIAL LINE TRANSCEIVERS**

SLLS073D - MAY 1976 - REVISED MAY 1998

PARAMETER MEASUREMENT INFORMATION

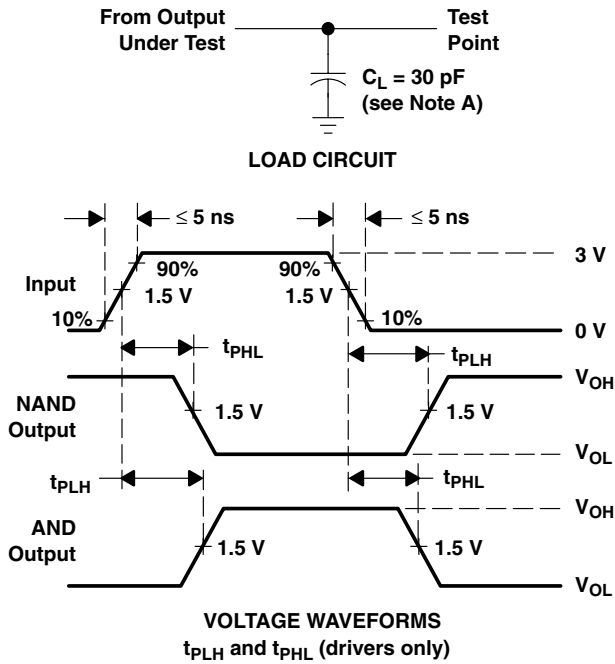

Figure 13

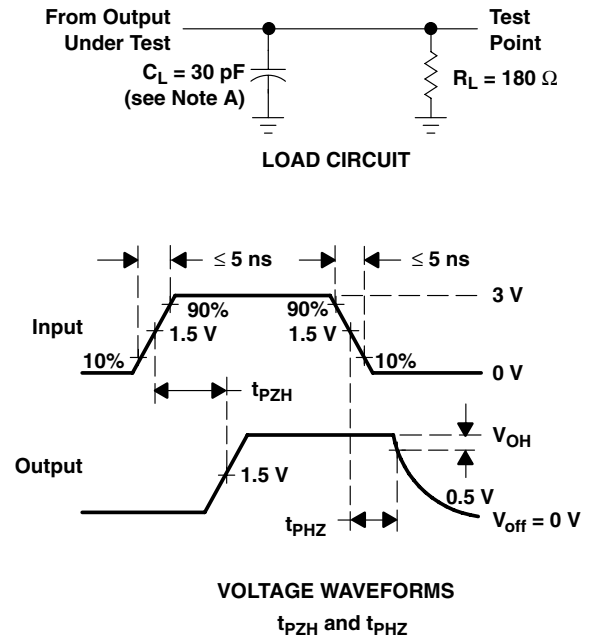

Figure 14

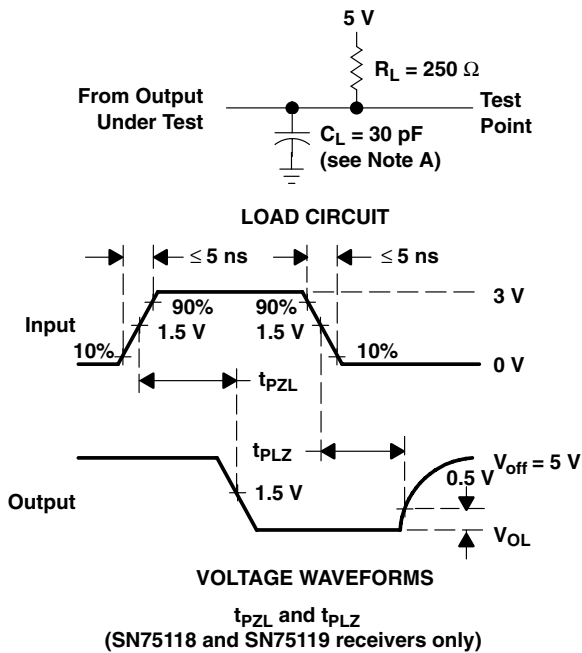

Figure 15

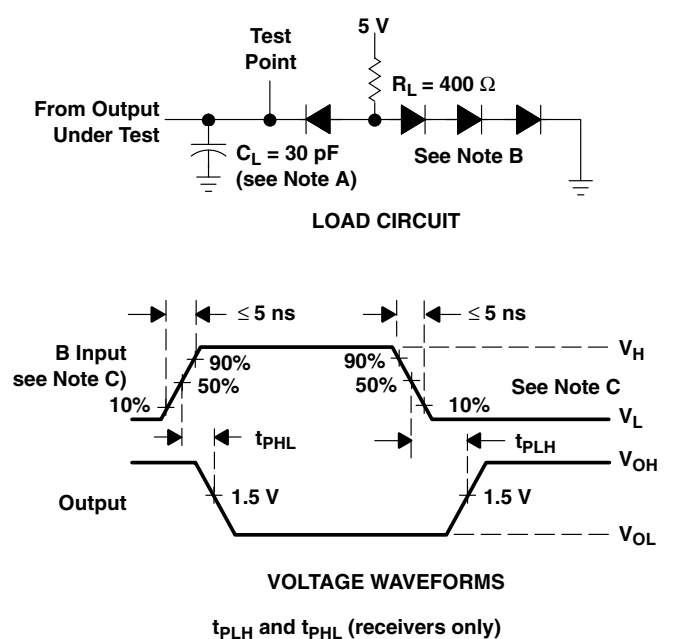

Figure 16

- NOTES: A. C_L includes probe and jig capacitance.
 B. All diodes are 1N3064 or equivalent.
 C. For '116 and SN75118, $V_H = 3\text{ V}$, $V_L = -3\text{ V}$, the A input is at 0 V.
 For SN75117 and SN75119, $V_H = 3\text{ V}$, $V_L = 0$, the A input is at 1.5 V.
 D. When testing the '116 and SN75118 receiver sections, the response-time control and the termination resistor pins are left open.



PACKAGING INFORMATION

| Orderable Device | Status (1) | Package Type | Package Drawing | Pins | Package Qty | Eco Plan (2) | Lead/Ball Finish (6) | MSL Peak Temp (3) | Op Temp (°C) | Device Marking (4/5) | Samples |
|------------------|---------------|--------------|-----------------|------|-------------|-------------------------|-------------------------|----------------------|--------------|------------------------------|---------|
| 5962-88511012A | ACTIVE | LCCC | FK | 20 | 1 | TBD | POST-PLATE | N / A for Pkg Type | -55 to 125 | 5962-88511012A SNJ55116FK | Samples |
| 5962-8851101EA | ACTIVE | CDIP | J | 16 | 1 | TBD | A42 | N / A for Pkg Type | -55 to 125 | 5962-8851101EA SNJ55116J | Samples |
| SN55116J | OBSOLETE | CDIP | J | 16 | | TBD | Call TI | Call TI | -55 to 125 | | |
| SN75116D | ACTIVE | SOIC | D | 16 | 40 | Green (RoHS & no Sb/Br) | CU NIPDAU | Level-1-260C-UNLIM | 0 to 70 | SN75116 | Samples |
| SN75116N | ACTIVE | PDIP | N | 16 | 25 | Pb-Free (RoHS) | CU NIPDAU | N / A for Pkg Type | 0 to 70 | SN75116N | Samples |
| SN75116NE4 | ACTIVE | PDIP | N | 16 | 25 | Pb-Free (RoHS) | CU NIPDAU | N / A for Pkg Type | 0 to 70 | SN75116N | Samples |
| SN75116NSR | ACTIVE | SO | NS | 16 | 2000 | Green (RoHS & no Sb/Br) | CU NIPDAU | Level-1-260C-UNLIM | 0 to 70 | SN75116 | Samples |
| SN75117D | OBSOLETE | SOIC | D | 8 | | TBD | Call TI | Call TI | 0 to 70 | | |
| SN75117P | ACTIVE | PDIP | P | 8 | 50 | Pb-Free (RoHS) | CU NIPDAU | N / A for Pkg Type | 0 to 70 | SN75117P | Samples |
| SN75118D | OBSOLETE | SOIC | D | 16 | | TBD | Call TI | Call TI | 0 to 70 | | |
| SN75118N | ACTIVE | PDIP | N | 16 | 25 | Pb-Free (RoHS) | CU NIPDAU | N / A for Pkg Type | 0 to 70 | SN75118N | Samples |
| SN75119D | ACTIVE | SOIC | D | 8 | 75 | Green (RoHS & no Sb/Br) | CU NIPDAU | Level-2-260C-1 YEAR | 0 to 70 | 75119 | Samples |
| SN75119P | ACTIVE | PDIP | P | 8 | 50 | Pb-Free (RoHS) | CU NIPDAU | N / A for Pkg Type | 0 to 70 | SN75119P | Samples |
| SNJ55116FK | ACTIVE | LCCC | FK | 20 | 1 | TBD | POST-PLATE | N / A for Pkg Type | -55 to 125 | 5962-88511012A SNJ55116FK | Samples |
| SNJ55116J | ACTIVE | CDIP | J | 16 | 1 | TBD | A42 | N / A for Pkg Type | -55 to 125 | 5962-8851101EA SNJ55116J | Samples |

(1) The marketing status values are defined as follows:

ACTIVE: Product device recommended for new designs.

LIFEBUY: TI has announced that the device will be discontinued, and a lifetime-buy period is in effect.



NRND: Not recommended for new designs. Device is in production to support existing customers, but TI does not recommend using this part in a new design.

PREVIEW: Device has been announced but is not in production. Samples may or may not be available.

OBSOLETE: TI has discontinued the production of the device.

⁽²⁾ Eco Plan - The planned eco-friendly classification: Pb-Free (RoHS), Pb-Free (RoHS Exempt), or Green (RoHS & no Sb/Br) - please check <http://www.ti.com/productcontent> for the latest availability information and additional product content details.

TBD: The Pb-Free/Green conversion plan has not been defined.

Pb-Free (RoHS): TI's terms "Lead-Free" or "Pb-Free" mean semiconductor products that are compatible with the current RoHS requirements for all 6 substances, including the requirement that lead not exceed 0.1% by weight in homogeneous materials. Where designed to be soldered at high temperatures, TI Pb-Free products are suitable for use in specified lead-free processes.

Pb-Free (RoHS Exempt): This component has a RoHS exemption for either 1) lead-based flip-chip solder bumps used between the die and package, or 2) lead-based die adhesive used between the die and leadframe. The component is otherwise considered Pb-Free (RoHS compatible) as defined above.

Green (RoHS & no Sb/Br): TI defines "Green" to mean Pb-Free (RoHS compatible), and free of Bromine (Br) and Antimony (Sb) based flame retardants (Br or Sb do not exceed 0.1% by weight in homogeneous material)

⁽³⁾ MSL, Peak Temp. - The Moisture Sensitivity Level rating according to the JEDEC industry standard classifications, and peak solder temperature.

⁽⁴⁾ There may be additional marking, which relates to the logo, the lot trace code information, or the environmental category on the device.

⁽⁵⁾ Multiple Device Markings will be inside parentheses. Only one Device Marking contained in parentheses and separated by a "~" will appear on a device. If a line is indented then it is a continuation of the previous line and the two combined represent the entire Device Marking for that device.

⁽⁶⁾ Lead/Ball Finish - Orderable Devices may have multiple material finish options. Finish options are separated by a vertical ruled line. Lead/Ball Finish values may wrap to two lines if the finish value exceeds the maximum column width.

Important Information and Disclaimer: The information provided on this page represents TI's knowledge and belief as of the date that it is provided. TI bases its knowledge and belief on information provided by third parties, and makes no representation or warranty as to the accuracy of such information. Efforts are underway to better integrate information from third parties. TI has taken and continues to take reasonable steps to provide representative and accurate information but may not have conducted destructive testing or chemical analysis on incoming materials and chemicals. TI and TI suppliers consider certain information to be proprietary, and thus CAS numbers and other limited information may not be available for release.

In no event shall TI's liability arising out of such information exceed the total purchase price of the TI part(s) at issue in this document sold by TI to Customer on an annual basis.

OTHER QUALIFIED VERSIONS OF SN55116, SN75116 :

● Catalog: [SN75116](#)

● Military: [SN55116](#)

NOTE: Qualified Version Definitions:



Distributor of Texas Instruments: Excellent Integrated System Limited

Datasheet of SN75116N - IC DIFF LINE TRANS 16-DIP

Contact us: sales@integrated-circuit.com Website: www.integrated-circuit.com

PACKAGE OPTION ADDENDUM



www.ti.com

24-Aug-2014

- Catalog - TI's standard catalog product
- Military - QML certified for Military and Defense Applications

TAPE AND REEL INFORMATION

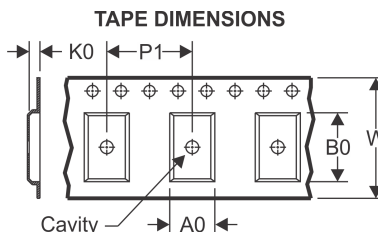
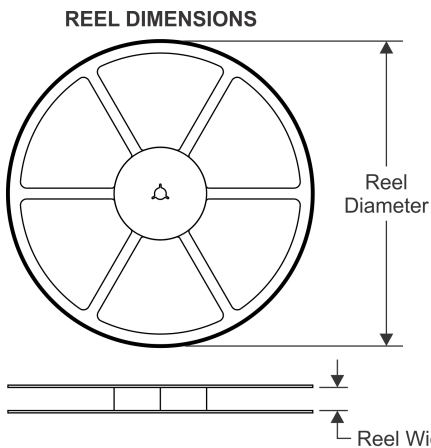

| | |
|----|---|
| A0 | Dimension designed to accommodate the component width |
| B0 | Dimension designed to accommodate the component length |
| K0 | Dimension designed to accommodate the component thickness |
| W | Overall width of the carrier tape |
| P1 | Pitch between successive cavity centers |

QUADRANT ASSIGNMENTS FOR PIN 1 ORIENTATION IN TAPE

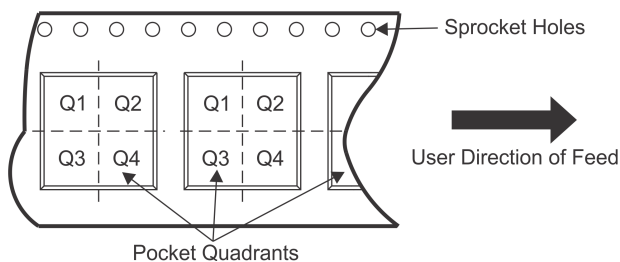

*All dimensions are nominal

| Device | Package Type | Package Drawing | Pins | SPQ | Reel Diameter (mm) | Reel Width W1 (mm) | A0 (mm) | B0 (mm) | K0 (mm) | P1 (mm) | W (mm) | Pin1 Quadrant |
|------------|--------------|-----------------|------|------|--------------------|--------------------|---------|---------|---------|---------|--------|---------------|
| SN75116NSR | SO | NS | 16 | 2000 | 330.0 | 16.4 | 8.2 | 10.5 | 2.5 | 12.0 | 16.0 | Q1 |

TAPE AND REEL BOX DIMENSIONS



*All dimensions are nominal

| Device | Package Type | Package Drawing | Pins | SPQ | Length (mm) | Width (mm) | Height (mm) |
|------------|--------------|-----------------|------|------|-------------|------------|-------------|
| SN75116NSR | SO | NS | 16 | 2000 | 367.0 | 367.0 | 38.0 |

J (R-GDIP-T**)

14 LEADS SHOWN

CERAMIC DUAL IN-LINE PACKAGE

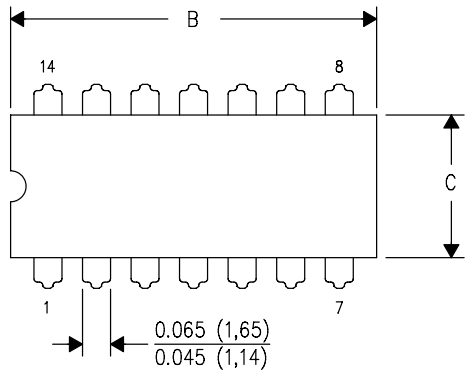

| DIM \ PINS ** | 14 | 16 | 18 | 20 |
|---------------|------------------------|------------------------|------------------------|------------------------|
| A | 0.300 (7,62) BSC | 0.300 (7,62) BSC | 0.300 (7,62) BSC | 0.300 (7,62) BSC |
| B MAX | 0.785 (19,94) | .840 (21,34) | 0.960 (24,38) | 1.060 (26,92) |
| B MIN | — | — | — | — |
| C MAX | 0.300 (7,62) | 0.300 (7,62) | 0.310 (7,87) | 0.300 (7,62) |
| C MIN | 0.245 (6,22) | 0.245 (6,22) | 0.220 (5,59) | 0.245 (6,22) |

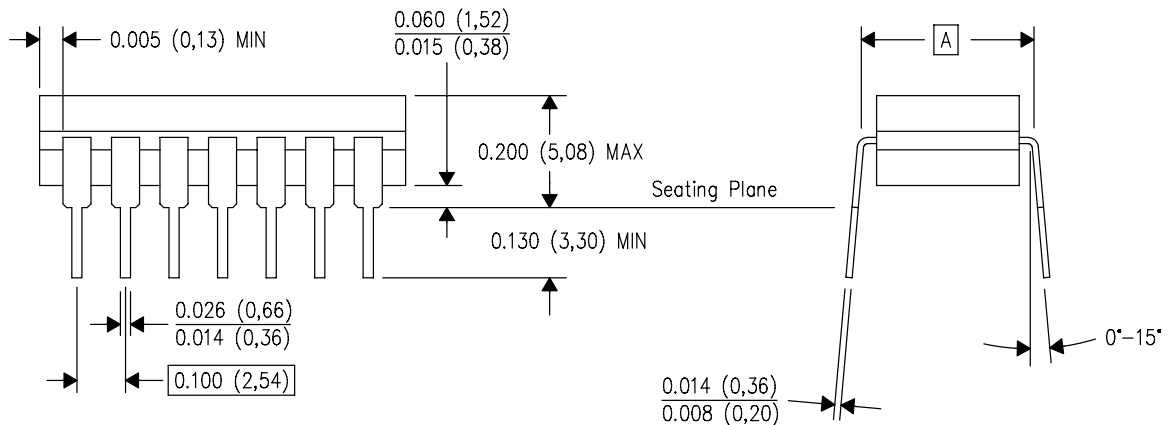

4040083/F 03/03

- NOTES:
- A. All linear dimensions are in inches (millimeters).
 - B. This drawing is subject to change without notice.
 - C. This package is hermetically sealed with a ceramic lid using glass frit.
 - D. Index point is provided on cap for terminal identification only on press ceramic glass frit seal only.
 - E. Falls within MIL STD 1835 GDIP1-T14, GDIP1-T16, GDIP1-T18 and GDIP1-T20.

FK (S-CQCC-N**)

LEADLESS CERAMIC CHIP CARRIER

28 TERMINAL SHOWN

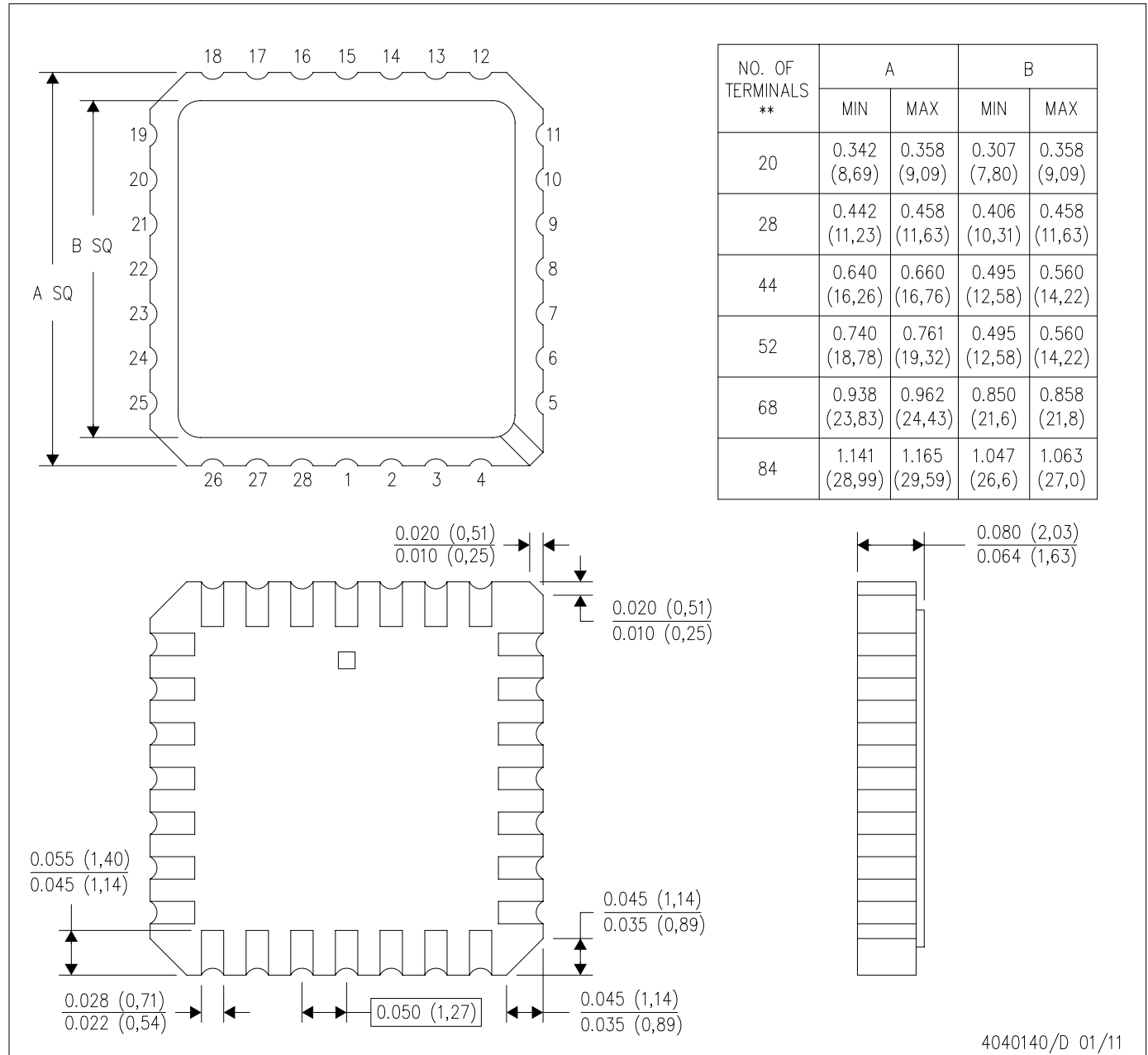

4040140/D 01/11

- NOTES:
- All linear dimensions are in inches (millimeters).
 - This drawing is subject to change without notice.
 - This package can be hermetically sealed with a metal lid.
 - Falls within JEDEC MS-004

MECHANICAL DATA

P (R-PDIP-T8)

PLASTIC DUAL-IN-LINE PACKAGE

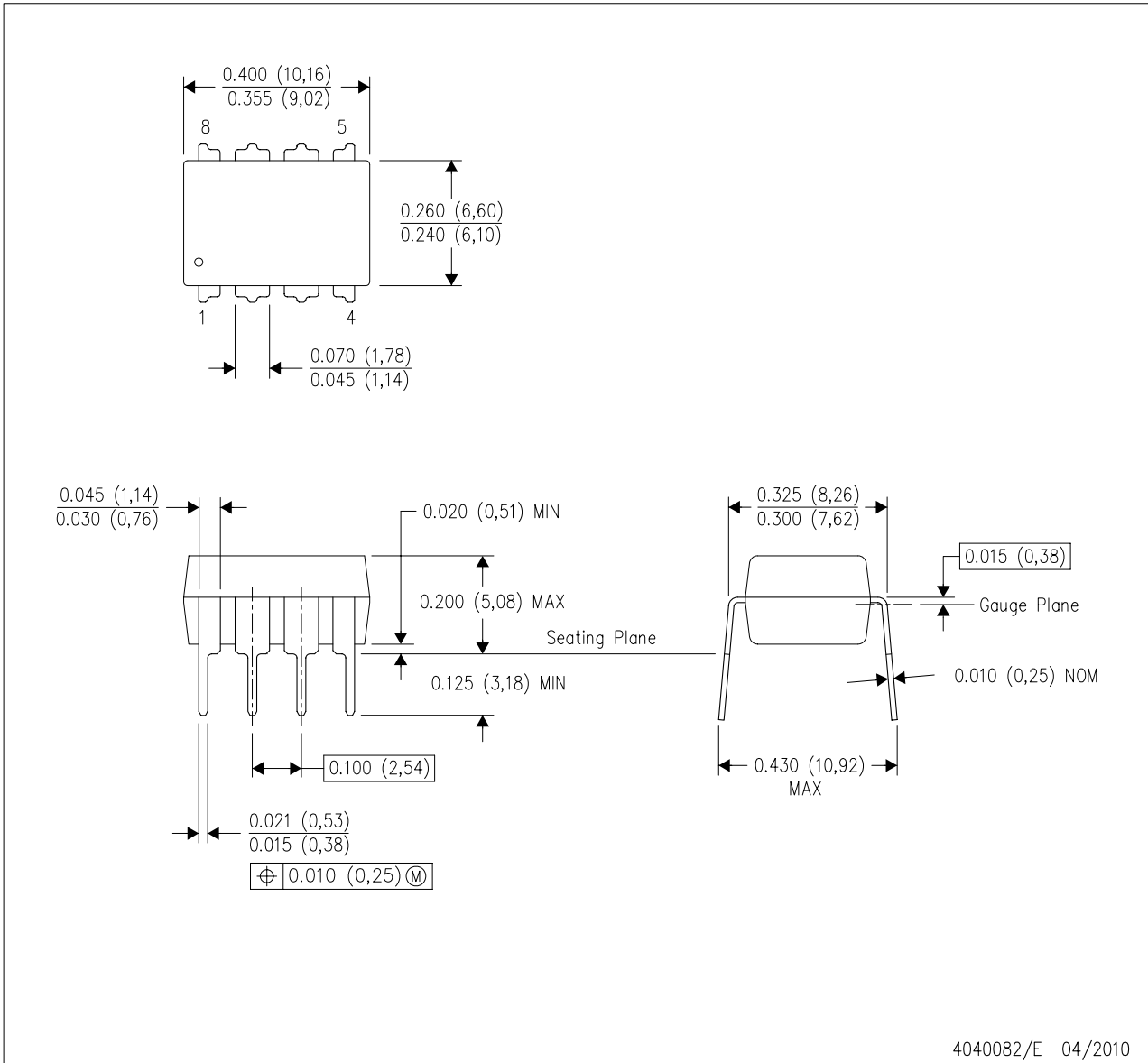

- NOTES:
- A. All linear dimensions are in inches (millimeters).
 - B. This drawing is subject to change without notice.
 - C. Falls within JEDEC MS-001 variation BA.

MECHANICAL DATA

N (R-PDIP-T)**

16 PINS SHOWN

PLASTIC DUAL-IN-LINE PACKAGE

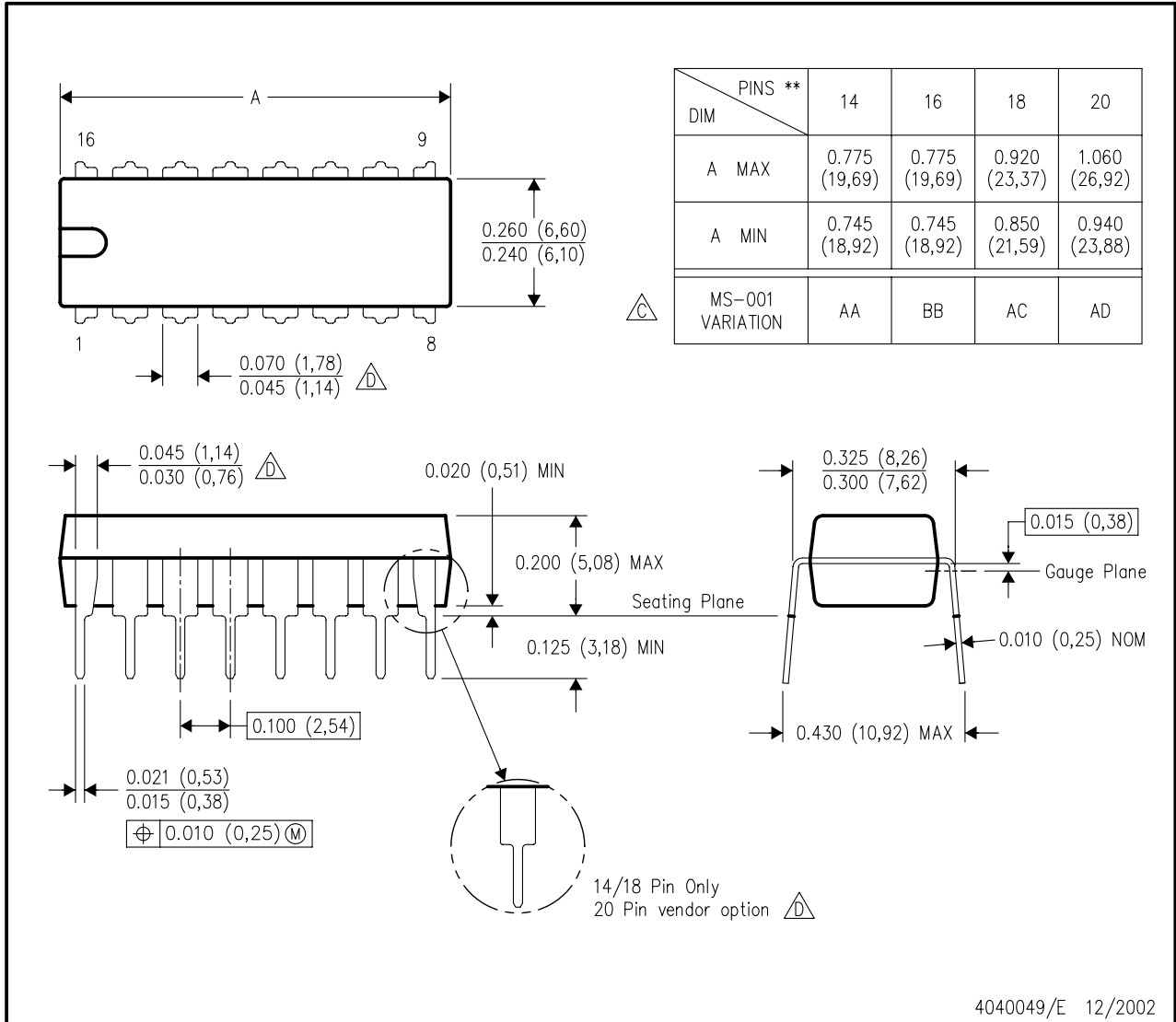

4040049/E 12/2002

- NOTES:
- A. All linear dimensions are in inches (millimeters).
 - B. This drawing is subject to change without notice.
 - Falls within JEDEC MS-001, except 18 and 20 pin minimum body length (Dim A).
 - The 20 pin end lead shoulder width is a vendor option, either half or full width.

MECHANICAL DATA

D (R-PDSO-G16)

PLASTIC SMALL OUTLINE

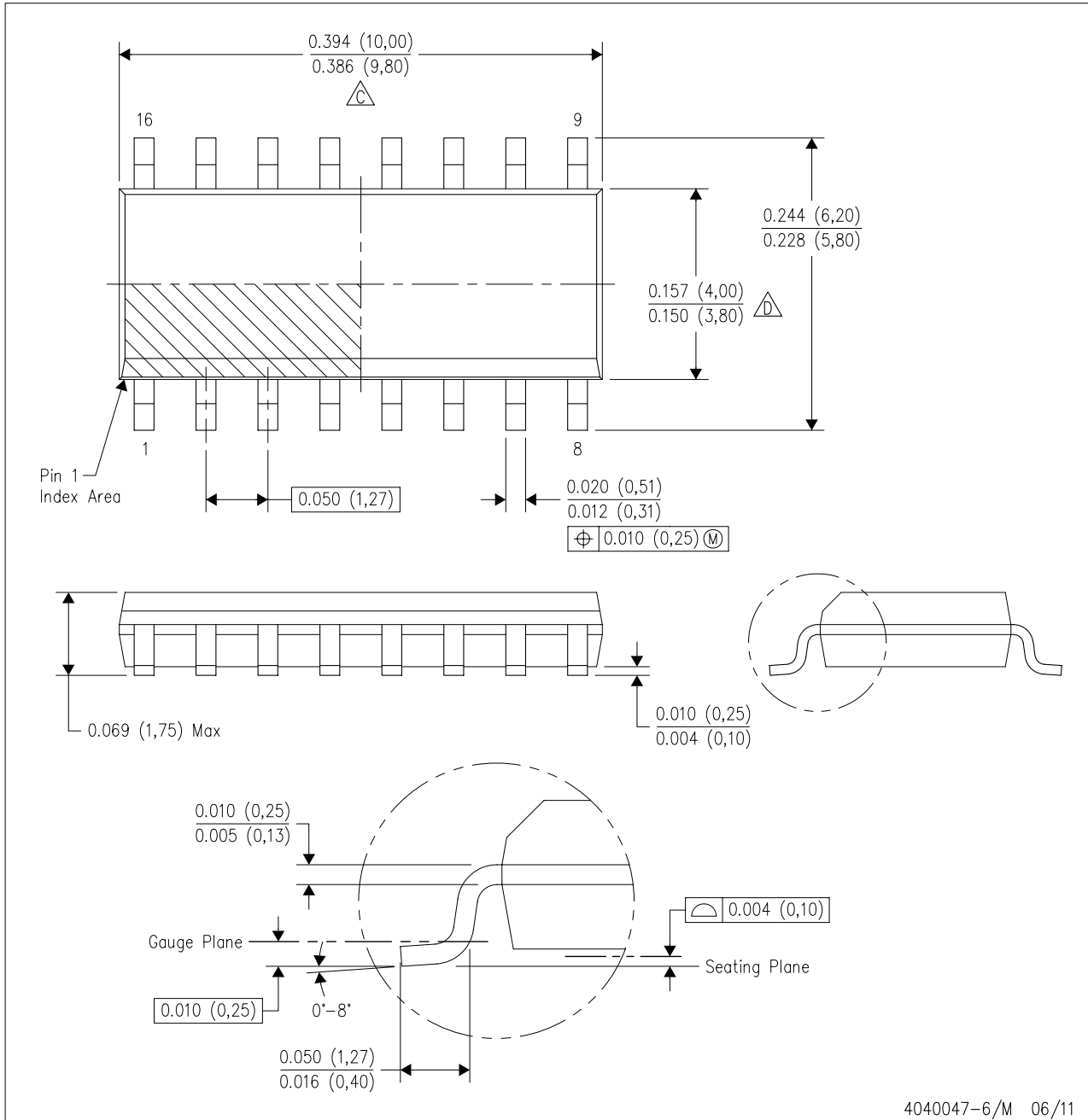

- NOTES:
- A. All linear dimensions are in inches (millimeters).
 - B. This drawing is subject to change without notice.
 - Body length does not include mold flash, protrusions, or gate burrs. Mold flash, protrusions, or gate burrs shall not exceed 0.006 (0,15) each side.
 - Body width does not include interlead flash. Interlead flash shall not exceed 0.017 (0,43) each side.
 - E. Reference JEDEC MS-012 variation AC.

LAND PATTERN DATA

D (R-PDSO-G16)

PLASTIC SMALL OUTLINE

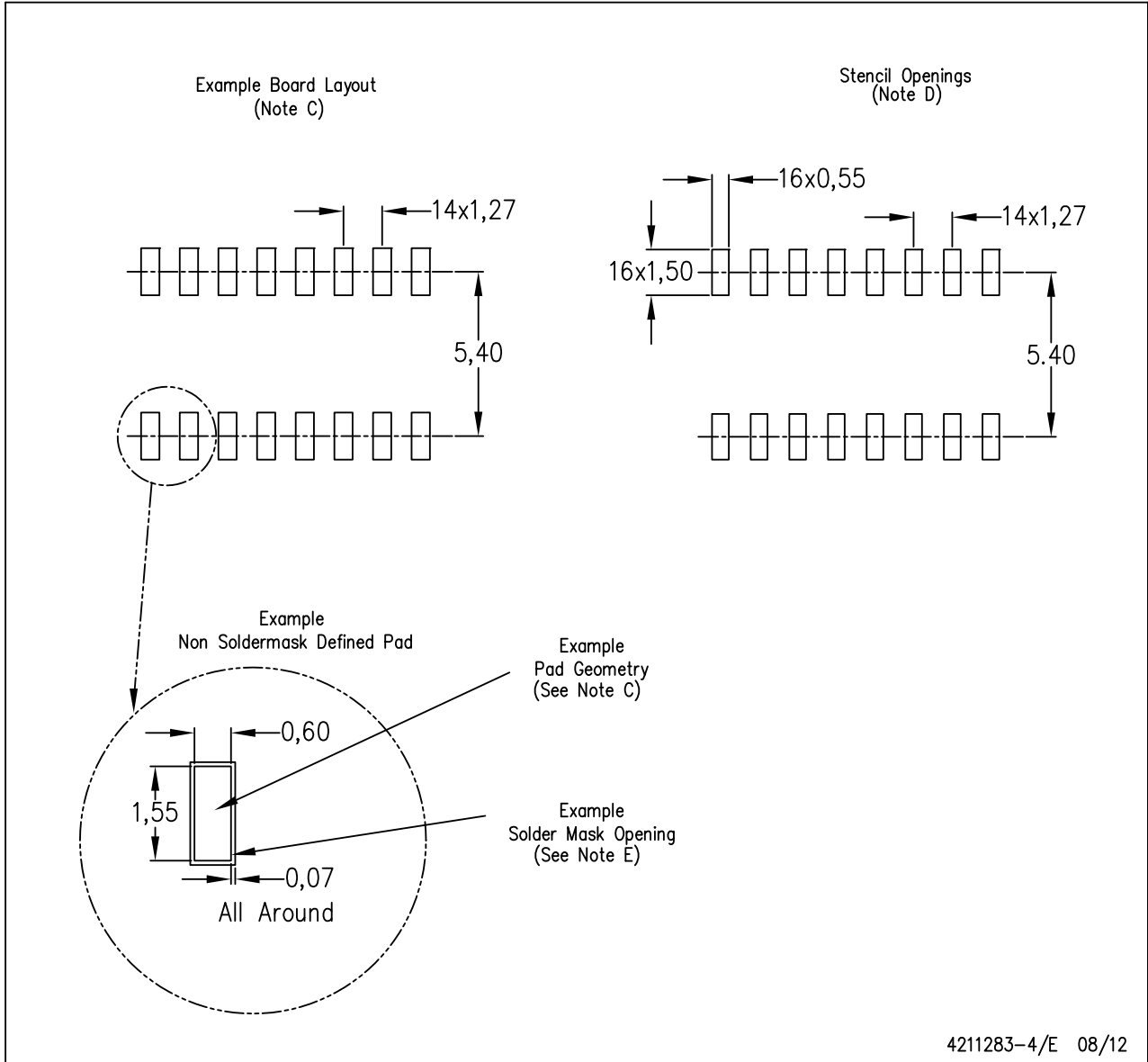

- NOTES:
- A. All linear dimensions are in millimeters.
 - B. This drawing is subject to change without notice.
 - C. Publication IPC-7351 is recommended for alternate designs.
 - D. Laser cutting apertures with trapezoidal walls and also rounding corners will offer better paste release. Customers should contact their board assembly site for stencil design recommendations. Refer to IPC-7525 for other stencil recommendations.
 - E. Customers should contact their board fabrication site for solder mask tolerances between and around signal pads.

MECHANICAL DATA

D (R-PDSO-G8)

PLASTIC SMALL OUTLINE

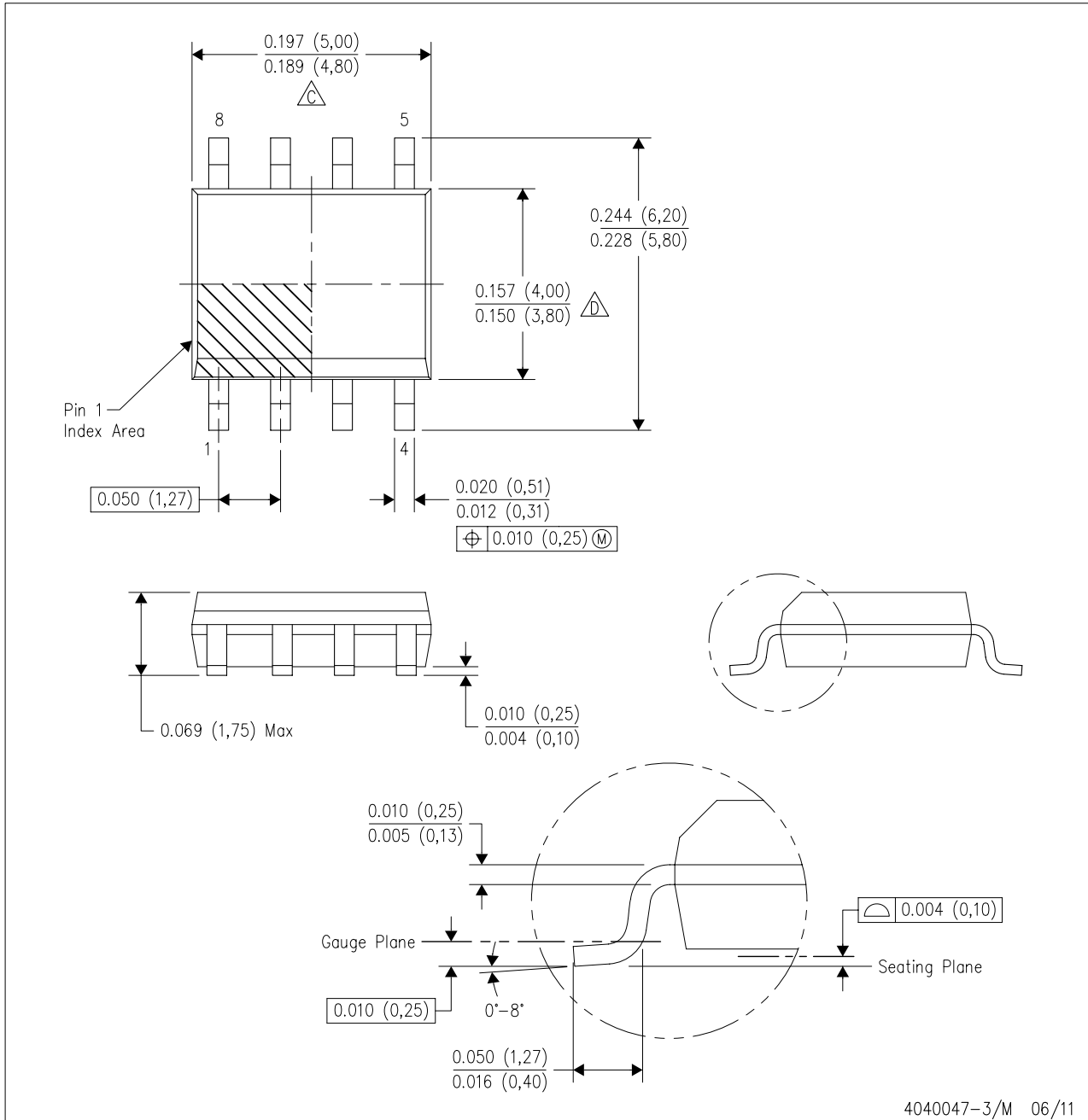

- NOTES:
- A. All linear dimensions are in inches (millimeters).
 - B. This drawing is subject to change without notice.
 - $\triangle C$ Body length does not include mold flash, protrusions, or gate burrs. Mold flash, protrusions, or gate burrs shall not exceed 0.006 (0,15) each side.
 - $\triangle D$ Body width does not include interlead flash. Interlead flash shall not exceed 0.017 (0,43) each side.
 - E. Reference JEDEC MS-012 variation AA.

LAND PATTERN DATA

D (R-PDSO-G8)

PLASTIC SMALL OUTLINE

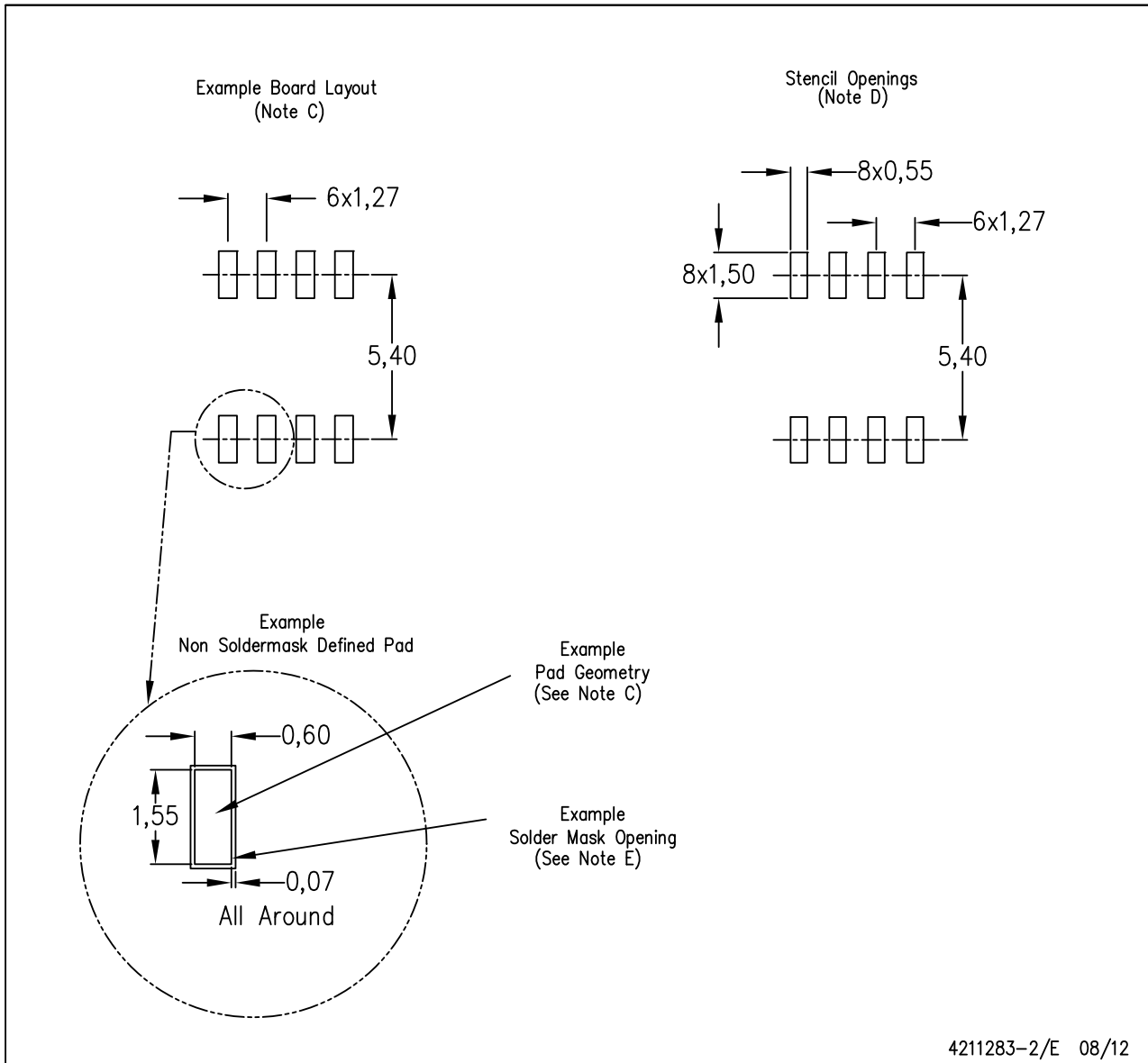

- NOTES:
- All linear dimensions are in millimeters.
 - This drawing is subject to change without notice.
 - Publication IPC-7351 is recommended for alternate designs.
 - Laser cutting apertures with trapezoidal walls and also rounding corners will offer better paste release. Customers should contact their board assembly site for stencil design recommendations. Refer to IPC-7525 for other stencil recommendations.
 - Customers should contact their board fabrication site for solder mask tolerances between and around signal pads.

MECHANICAL DATA

NS (R-PDSO-G)**

PLASTIC SMALL-OUTLINE PACKAGE

14-PINS SHOWN

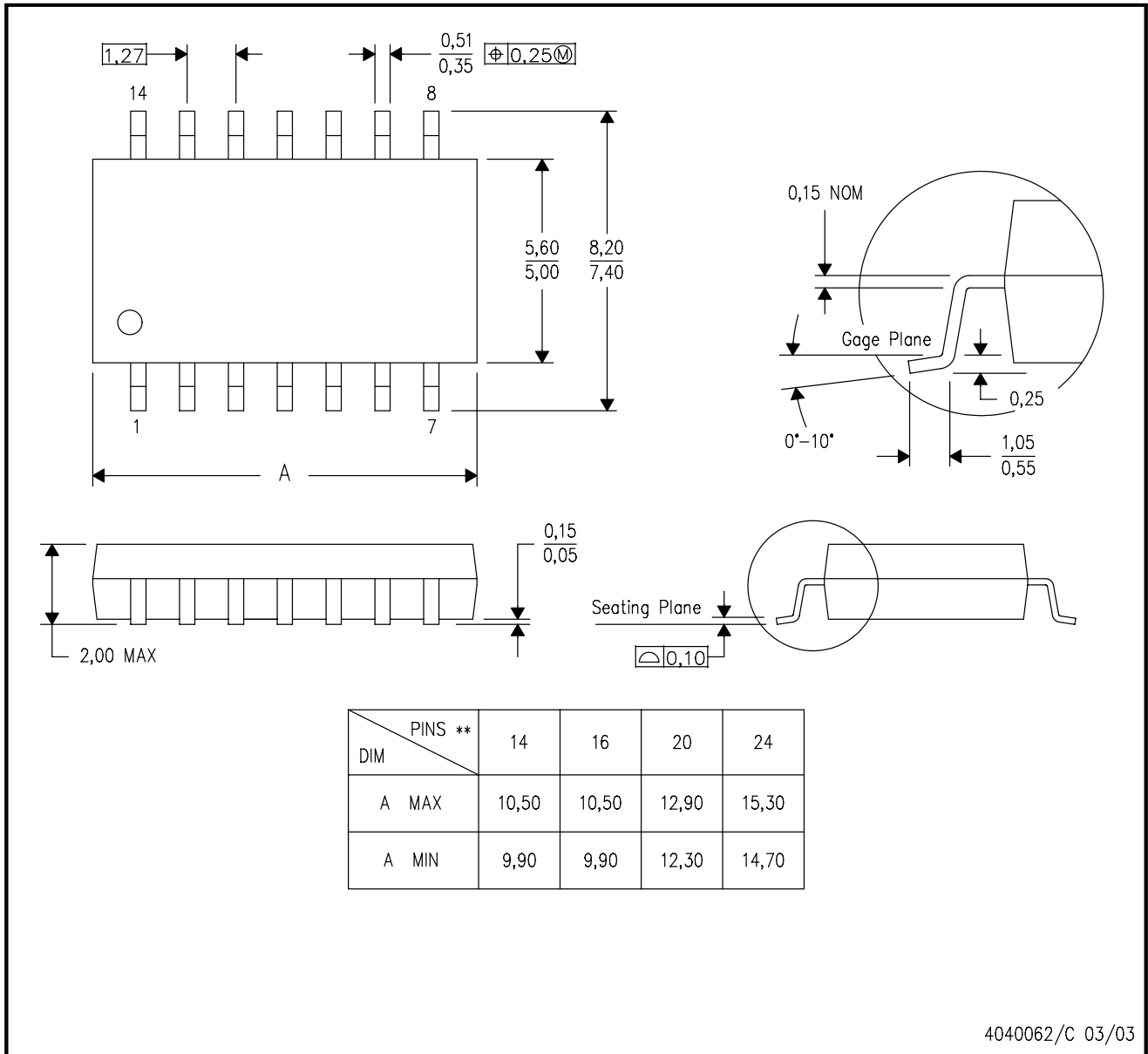

- NOTES:
- A. All linear dimensions are in millimeters.
 - B. This drawing is subject to change without notice.
 - C. Body dimensions do not include mold flash or protrusion, not to exceed 0,15.

IMPORTANT NOTICE

Texas Instruments Incorporated and its subsidiaries (TI) reserve the right to make corrections, enhancements, improvements and other changes to its semiconductor products and services per JESD46, latest issue, and to discontinue any product or service per JESD48, latest issue. Buyers should obtain the latest relevant information before placing orders and should verify that such information is current and complete. All semiconductor products (also referred to herein as "components") are sold subject to TI's terms and conditions of sale supplied at the time of order acknowledgment.

TI warrants performance of its components to the specifications applicable at the time of sale, in accordance with the warranty in TI's terms and conditions of sale of semiconductor products. Testing and other quality control techniques are used to the extent TI deems necessary to support this warranty. Except where mandated by applicable law, testing of all parameters of each component is not necessarily performed.

TI assumes no liability for applications assistance or the design of Buyers' products. Buyers are responsible for their products and applications using TI components. To minimize the risks associated with Buyers' products and applications, Buyers should provide adequate design and operating safeguards.

TI does not warrant or represent that any license, either express or implied, is granted under any patent right, copyright, mask work right, or other intellectual property right relating to any combination, machine, or process in which TI components or services are used. Information published by TI regarding third-party products or services does not constitute a license to use such products or services or a warranty or endorsement thereof. Use of such information may require a license from a third party under the patents or other intellectual property of the third party, or a license from TI under the patents or other intellectual property of TI.

Reproduction of significant portions of TI information in TI data books or data sheets is permissible only if reproduction is without alteration and is accompanied by all associated warranties, conditions, limitations, and notices. TI is not responsible or liable for such altered documentation. Information of third parties may be subject to additional restrictions.

Resale of TI components or services with statements different from or beyond the parameters stated by TI for that component or service voids all express and any implied warranties for the associated TI component or service and is an unfair and deceptive business practice. TI is not responsible or liable for any such statements.

Buyer acknowledges and agrees that it is solely responsible for compliance with all legal, regulatory and safety-related requirements concerning its products, and any use of TI components in its applications, notwithstanding any applications-related information or support that may be provided by TI. Buyer represents and agrees that it has all the necessary expertise to create and implement safeguards which anticipate dangerous consequences of failures, monitor failures and their consequences, lessen the likelihood of failures that might cause harm and take appropriate remedial actions. Buyer will fully indemnify TI and its representatives against any damages arising out of the use of any TI components in safety-critical applications.

In some cases, TI components may be promoted specifically to facilitate safety-related applications. With such components, TI's goal is to help enable customers to design and create their own end-product solutions that meet applicable functional safety standards and requirements. Nonetheless, such components are subject to these terms.

No TI components are authorized for use in FDA Class III (or similar life-critical medical equipment) unless authorized officers of the parties have executed a special agreement specifically governing such use.

Only those TI components which TI has specifically designated as military grade or "enhanced plastic" are designed and intended for use in military/aerospace applications or environments. Buyer acknowledges and agrees that any military or aerospace use of TI components which have **not** been so designated is solely at the Buyer's risk, and that Buyer is solely responsible for compliance with all legal and regulatory requirements in connection with such use.

TI has specifically designated certain components as meeting ISO/TS16949 requirements, mainly for automotive use. In any case of use of non-designated products, TI will not be responsible for any failure to meet ISO/TS16949.

Products

| | |
|------------------------------|--|
| Audio | www.ti.com/audio |
| Amplifiers | amplifier.ti.com |
| Data Converters | dataconverter.ti.com |
| DLP® Products | www.dlp.com |
| DSP | dsp.ti.com |
| Clocks and Timers | www.ti.com/clocks |
| Interface | interface.ti.com |
| Logic | logic.ti.com |
| Power Mgmt | power.ti.com |
| Microcontrollers | microcontroller.ti.com |
| RFID | www.ti-rfid.com |
| OMAP Applications Processors | www.ti.com/omap |
| Wireless Connectivity | www.ti.com/wirelessconnectivity |

Applications

| | |
|-------------------------------|--|
| Automotive and Transportation | www.ti.com/automotive |
| Communications and Telecom | www.ti.com/communications |
| Computers and Peripherals | www.ti.com/computers |
| Consumer Electronics | www.ti.com/consumer-apps |
| Energy and Lighting | www.ti.com/energy |
| Industrial | www.ti.com/industrial |
| Medical | www.ti.com/medical |
| Security | www.ti.com/security |
| Space, Avionics and Defense | www.ti.com/space-avionics-defense |
| Video and Imaging | www.ti.com/video |

TI E2E Community

e2e.ti.com