

Excellent Integrated System Limited

Stocking Distributor

Click to view price, real time Inventory, Delivery & Lifecycle Information:

[Harwin Inc.](#)
[M7765-05](#)

For any questions, you can email us directly:
sales@integrated-circuit.com

Customer Information Sheet

DRAWING No.: M7765/66/67/71-XX

SHEET 2 OF 2

IF IN DOUBT - ASK

©

NOT TO SCALE

THIRD ANGLE PROJECTION

ALL DIMENSIONS IN mm

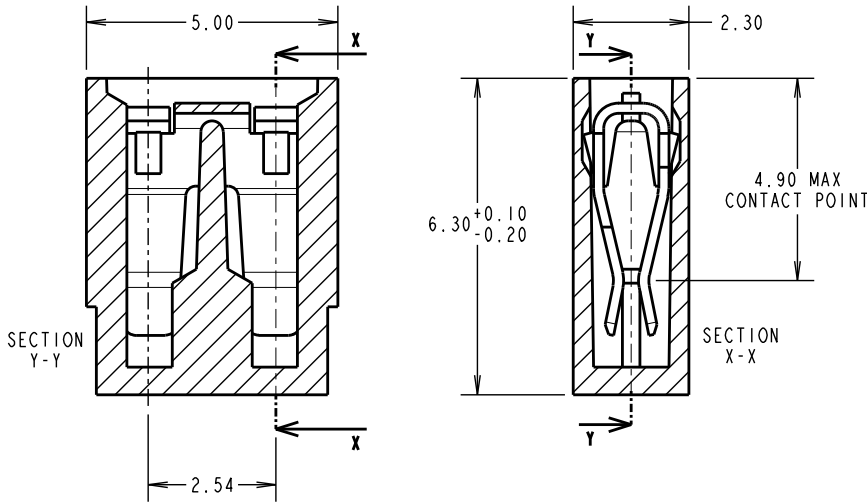

SPECIFICATIONS:

MATERIAL:

MOULDING = GLASS FILLED POLYESTER UL94V-0
(SEE ORDER CODE FOR COLOUR)

CLIP = PHOSPHOR BRONZE

FINISH:

05 = 0.13µ GOLD

46 = 3µ 100% TIN

ELECTRICAL:

CURRENT RATING = 3A MAX

VOLTAGE RATING = 250V AC/DC

VOLTAGE PROOF = 750V AC

CONTACT RESISTANCE = 30mΩ MAX (TIN), 25mΩ MAX (GOLD)

INSULATION RESISTANCE = 1,000MΩ MIN

MECHANICAL:

DURABILITY = 50 OPERATIONS (TIN), 300 OPERATIONS (GOLD)

INSERTION FORCE = 14.5N MAX

WITHDRAWAL FORCE = 1.0N MIN

ENVIRONMENTAL:

TEMPERATURE RANGE = -40°C TO +85°C

PACKING:

BAG

- NOTES:**
- MATING PIN = 0.64mm SQUARE.
 - FOR COMPLETE SPECIFICATION, SEE COMPONENT SPECIFICATION C003XX (LATEST ISSUE).

ORDER CODE: **M77XX-XX**

MOULDING COLOUR

65 - LT. GREY	66 - RED
67 - BLACK	71 - BLUE

CONTACT FINISH

05 - GOLD
46 = 100% TIN

MSP	10	22.10.14	12634
NAME	ISS.	DATE	C/NOTE
APPROVED: M.PERREN			
CHECKED: M.PLESTED			
DRAWN: J.CLAY			
CUSTOMER REF.:			
ASSEMBLY DRG:			

HARWIN

www.harwin.com
technical@harwin.com

THIS DRAWING AND ANY INFORMATION OR DESCRIPTIVE MATTER SET OUT HEREON ARE CONFIDENTIAL AND COPYRIGHT PROPERTY OF THE HARWIN GROUP AND MUST NOT BE DISCLOSED, LOANED, COPIED OR USED FOR MANUFACTURING, TENDERING OR FOR ANY OTHER PURPOSE WITHOUT THEIR WRITTEN PERMISSION.

TOLERANCES

X. = ±1mm
X.X = ±0.25mm
X.XX = ±0.10mm
X.XXX = ±0.01mm

ANGLES = ±5°
UNLESS STATED

MATERIAL: SEE ABOVE

FINISH: SEE ABOVE

S/AREA: mm²

TITLE: CLOSED TOP JUMPER SOCKET

DRAWING NUMBER: M7765-XX, M7766-XX, M7767-XX, M7771-XX

SHT 2 OF 2