



Distributor of Texas Instruments: Excellent Integrated System Limited

Datasheet of SN74ABT16600DLR - IC UNIV BUS TXRX 18BIT 56SSOP

Contact us: sales@integrated-circuit.com Website: www.integrated-circuit.com

Excellent Integrated System Limited

Stocking Distributor

Click to view price, real time Inventory, Delivery & Lifecycle Information:

[Texas Instruments](#)
[SN74ABT16600DLR](#)

For any questions, you can email us directly:

sales@integrated-circuit.com

SN54ABT16600, SN74ABT16600
18-BIT UNIVERSAL BUS TRANSCEIVERS
WITH 3-STATE OUTPUTS

SCBS209B – JUNE 1992 – REVISED JANUARY 1997

- **Members of the Texas Instruments *Widebus*™ Family**
- **State-of-the-Art *EPIC-IIB*™ BiCMOS Design Significantly Reduces Power Dissipation**
- ***UBT*™ (Universal Bus Transceiver) Combines D-Type Latches and D-Type Flip-Flops for Operation in Transparent, Latched, Clocked, or Clock-Enabled Mode**
- **ESD Protection Exceeds 2000 V Per MIL-STD-883, Method 3015**
- **Latch-Up Performance Exceeds 500 mA Per JEDEC Standard JESD-17**
- **Typical V_{OLP} (Output Ground Bounce) < 0.8 V at $V_{CC} = 5 V, T_A = 25^\circ C$**
- **Flow-Through Architecture Optimizes PCB Layout**
- **Package Options Include Plastic 300-mil Shrink Small-Outline (DL) and Thin Shrink Small-Outline (DGG) Packages and 380-mil Fine-Pitch Ceramic Flat (WD) Package Using 25-mil Center-to-Center Spacings**

SN54ABT16600 . . . WD PACKAGE
 SN74ABT16600 . . . DGG OR DL PACKAGE
 (TOP VIEW)

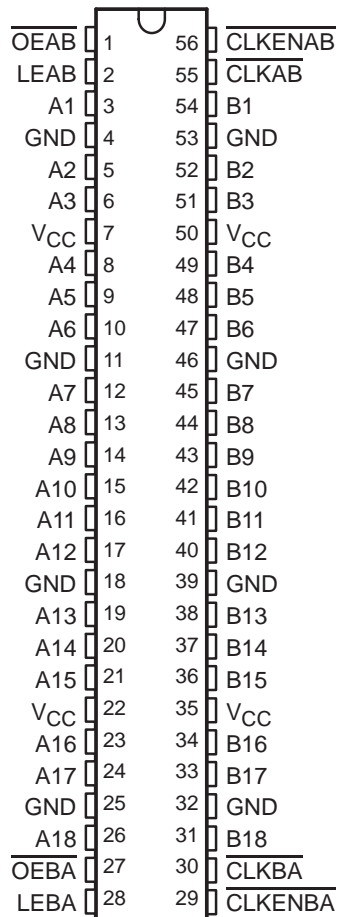

description

These 18-bit universal bus transceivers combine D-type latches and D-type flip-flops to allow data flow in transparent, latched, clocked, and clock-enabled modes.

Data flow in each direction is controlled by output-enable (\overline{OEAB} and \overline{OEBA}), latch-enable (LEAB and LEBA), and clock (\overline{CLKAB} and \overline{CLKBA}) inputs. The clock can be controlled by the clock-enable ($\overline{CLKENAB}$ and $\overline{CLKENBA}$) inputs. For A-to-B data flow, the device operates in the transparent mode when LEAB is high. When LEAB is low, the A data is latched if \overline{CLKAB} is held at a high or low logic level. If LEAB is low, the A-bus data is stored in the latch/flip-flop on the high-to-low transition of \overline{CLKAB} . Output enable \overline{OEAB} is active low. When \overline{OEAB} is low, the outputs are active. When \overline{OEAB} is high, the outputs are in the high-impedance state.



Please be aware that an important notice concerning availability, standard warranty, and use in critical applications of Texas Instruments semiconductor products and disclaimers thereto appears at the end of this data sheet.

Widebus, EPIC-IIB, and UBT are trademarks of Texas Instruments Incorporated.

UNLESS OTHERWISE NOTED this document contains PRODUCTION DATA information current as of publication date. Products conform to specifications per the terms of Texas Instruments standard warranty. Production processing does not necessarily include testing of all parameters.



POST OFFICE BOX 655303 • DALLAS, TEXAS 75265

Copyright © 1997, Texas Instruments Incorporated

SN54ABT16600, SN74ABT16600
18-BIT UNIVERSAL BUS TRANSCEIVERS
WITH 3-STATE OUTPUTS

SCBS209B – JUNE 1992 – REVISED JANUARY 1997

description (continued)

Data flow for B to A is similar to that of A to B, but uses \overline{OEBA} , LEBA, \overline{CLKBA} , and $\overline{CLKENBA}$.

To ensure the high-impedance state during power up or power down, \overline{OE} should be tied to V_{CC} through a pullup resistor; the minimum value of the resistor is determined by the current-sinking capability of the driver.

The SN54ABT16600 is characterized for operation over the full military temperature range of -55°C to 125°C . The SN74ABT16600 is characterized for operation from -40°C to 85°C .

FUNCTION TABLE†

| INPUTS | | | | | OUTPUT B |
|----------------------|-------------------|------|--------------------|---|------------------|
| $\overline{CLKENAB}$ | \overline{OEAB} | LEAB | \overline{CLKAB} | A | |
| X | H | X | X | X | Z |
| X | L | H | X | L | L |
| X | L | H | X | H | H |
| H | L | L | X | X | B_0^{\ddagger} |
| H | L | L | X | X | B_0^{\ddagger} |
| L | L | L | ↓ | L | L |
| L | L | L | ↓ | H | H |
| L | L | L | H | X | B_0^{\ddagger} |
| L | L | L | L | X | B_0^{\S} |

† A-to-B data flow is shown: B-to-A flow is similar but uses \overline{OEBA} , LEBA, \overline{CLKBA} , and $\overline{CLKENBA}$.

‡ Output level before the indicated steady-state input conditions were established

§ Output level before the indicated steady-state input conditions were established, provided that \overline{CLKAB} was low before LEAB went low

SN54ABT16600, SN74ABT16600
18-BIT UNIVERSAL BUS TRANSCEIVERS
WITH 3-STATE OUTPUTS

SCBS209B – JUNE 1992 – REVISED JANUARY 1997

logic diagram (positive logic)

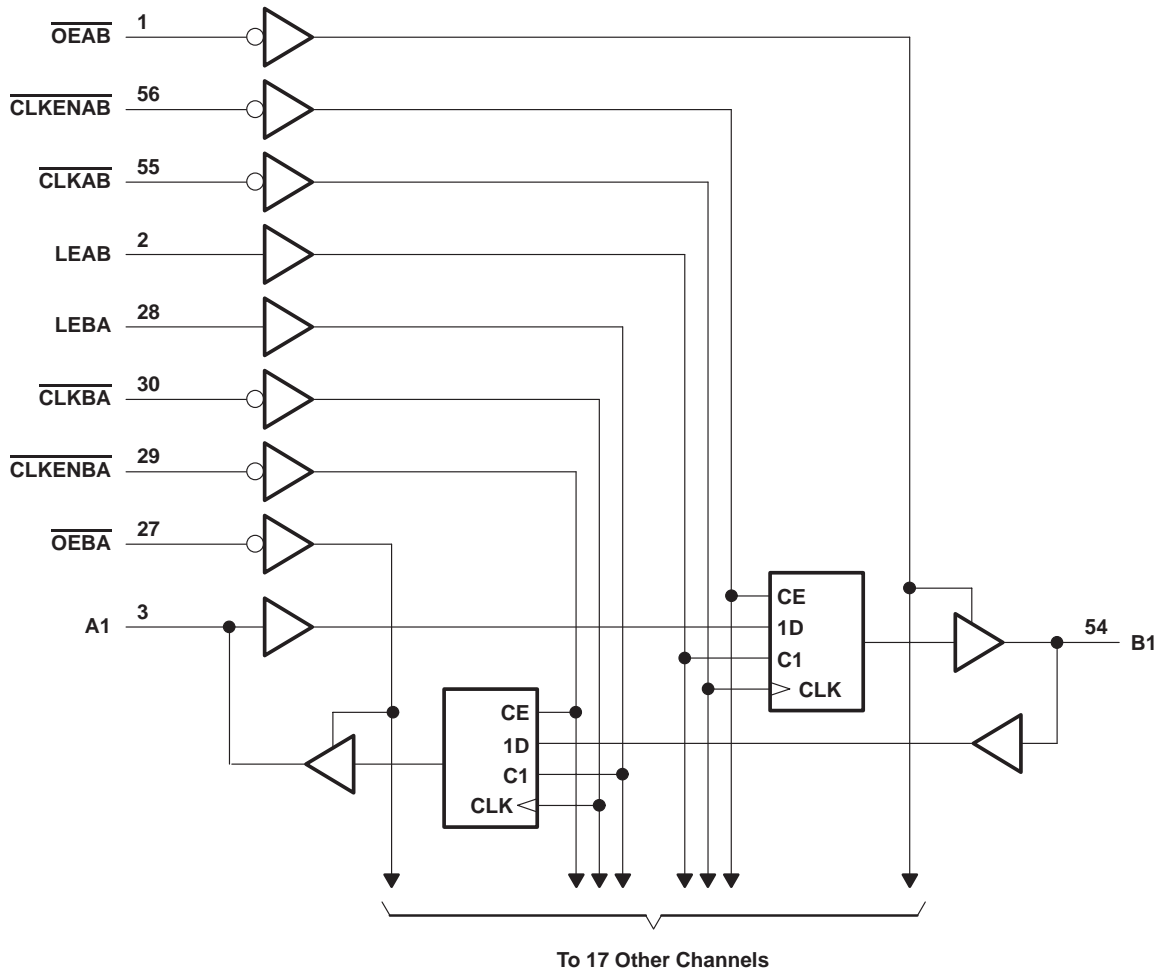

absolute maximum ratings over operating free-air temperature range (unless otherwise noted)†

| | |
|---|-----------------|
| Supply voltage range, V_{CC} | –0.5 V to 7 V |
| Input voltage range, V_I (except I/O ports) (see Note 1) | –0.5 V to 7 V |
| Voltage range applied to any output in the high or power-off state, V_O | –0.5 V to 5.5 V |
| Current into any output in the low state, I_{OL} : SN54ABT16600 | 96 mA |
| SN74ABT16600 | 128 mA |
| Input clamp current, I_{IK} ($V_I < 0$) | –18 mA |
| Output clamp current, I_{OK} ($V_O < 0$) | –50 mA |
| Package thermal impedance, θ_{JA} (see Note 2): DGG package | 81°C/W |
| DL package | 74°C/W |
| Storage temperature range, T_{stg} | –65°C to 150°C |

† Stresses beyond those listed under “absolute maximum ratings” may cause permanent damage to the device. These are stress ratings only, and functional operation of the device at these or any other conditions beyond those indicated under “recommended operating conditions” is not implied. Exposure to absolute-maximum-rated conditions for extended periods may affect device reliability.

- NOTES: 1. The input and output negative-voltage ratings may be exceeded if the input and output clamp-current ratings are observed.
2. The package thermal impedance is calculated in accordance with EIA/JEDEC Std JESD51.

SN54ABT16600, SN74ABT16600

18-BIT UNIVERSAL BUS TRANSCEIVERS

WITH 3-STATE OUTPUTS

SCBS209B – JUNE 1992 – REVISED JANUARY 1997

recommended operating conditions (see Note 3)

| | SN54ABT16600 | | SN74ABT16600 | | UNIT |
|--|-----------------|----------|--------------|----------|------|
| | MIN | MAX | MIN | MAX | |
| V_{CC} Supply voltage | 4.5 | 5.5 | 4.5 | 5.5 | V |
| V_{IH} High-level input voltage | 2 | | 2 | | V |
| V_{IL} Low-level input voltage | | 0.8 | | 0.8 | V |
| V_I Input voltage | 0 | V_{CC} | 0 | V_{CC} | V |
| I_{OH} High-level output current | | -24 | | -32 | mA |
| I_{OL} Low-level output current | | 48 | | 64 | mA |
| $\Delta t/\Delta v$ Input transition rise or fall rate | Outputs enabled | | | 10 | ns/V |
| T_A Operating free-air temperature | -55 | 125 | -40 | 85 | °C |

NOTE 3: Unused pins (input or I/O) must be held high or low to prevent them from floating.

electrical characteristics over recommended operating free-air temperature range (unless otherwise noted)

| PARAMETER | TEST CONDITIONS | $T_A = 25^\circ\text{C}$ | | | SN54ABT16600 | | SN74ABT16600 | | UNIT | |
|-------------------|---|---|--------------|-----------|--------------|----------|--------------|-----------|---------------|----|
| | | MIN | TYP† | MAX | MIN | MAX | MIN | MAX | | |
| V_{IK} | $V_{CC} = 4.5\text{ V}$, $I_I = -18\text{ mA}$ | | | -1.2 | | -1.2 | | -1.2 | V | |
| V_{OH} | $V_{CC} = 4.5\text{ V}$, $I_{OH} = -3\text{ mA}$ | | 2.5 | | 2.5 | | 2.5 | | V | |
| | $V_{CC} = 5\text{ V}$, $I_{OH} = -3\text{ mA}$ | | 3 | | 3 | | 3 | | | |
| | $V_{CC} = 4.5\text{ V}$ | $I_{OH} = -24\text{ mA}$ | | 2 | | 2 | | | | |
| V_{OL} | $V_{CC} = 4.5\text{ V}$ | $I_{OL} = 48\text{ mA}$ | | 0.55 | | 0.55 | | | V | |
| | | $I_{OL} = 64\text{ mA}$ | | 0.55* | | | 0.55 | | | |
| V_{hys} | | | 100 | | | | | | mV | |
| I_I | Control inputs | $V_{CC} = 5.5\text{ V}$, $V_I = V_{CC}$ or GND | | ± 1 | | ± 1 | | ± 1 | μA | |
| | A or B ports | | | ± 20 | | ± 20 | | ± 20 | | |
| I_{off} | $V_{CC} = 0$, V_I or $V_O \leq 4.5\text{ V}$ | | | ± 100 | | | | ± 100 | μA | |
| I_{CEX} | $V_{CC} = 5.5\text{ V}$, $V_O = 5.5\text{ V}$ | Outputs high | | 50 | | 50 | | 50 | μA | |
| $I_{O\ddagger}$ | $V_{CC} = 5.5\text{ V}$, $V_O = 2.5\text{ V}$ | | -50 | -100 | -180 | -50 | -180 | -50 | -180 | mA |
| $I_{OZH}\S$ | $V_{CC} = 5.5\text{ V}$, $V_O = 2.7\text{ V}$ | | | 10 | | 10 | | 10 | μA | |
| $I_{OZL}\S$ | $V_{CC} = 5.5\text{ V}$, $V_O = 0.5\text{ V}$ | | | -10 | | -10 | | -10 | μA | |
| I_{CC} | A or B ports | $V_{CC} = 5.5\text{ V}$, $I_O = 0$, $V_I = V_{CC}$ or GND | Outputs high | | 3 | | 3 | | 3 | mA |
| | | Outputs low | | 36 | | 36 | | 36 | | |
| | | Outputs disabled | | 3 | | 3 | | 3 | | |
| $\Delta I_{CC}\P$ | $V_{CC} = 5.5\text{ V}$, One input at 3.4 V, Other inputs at V_{CC} or GND | | | 50 | | 50 | | 50 | μA | |
| C_i | Control inputs | $V_I = 2.5\text{ V}$ or 0.5 V | | 3 | | | | | pF | |
| C_{io} | A or B ports | $V_O = 2.5\text{ V}$ or 0.5 V | | 9 | | | | | pF | |

* On products compliant to MIL-PRF-38535, this parameter does not apply.

 † All typical values are at $V_{CC} = 5\text{ V}$.

‡ Not more than one output should be tested at a time, and the duration of the test should not exceed one second.

 § The parameters I_{OZH} and I_{OZL} include the input leakage current.

 ¶ This is the increase in supply current for each input that is at the specified TTL voltage level rather than V_{CC} or GND.

SN54ABT16600, SN74ABT16600
18-BIT UNIVERSAL BUS TRANSCEIVERS
WITH 3-STATE OUTPUTS

SCBS209B – JUNE 1992 – REVISED JANUARY 1997

timing requirements over recommended ranges of supply voltage and operating free-air temperature (unless otherwise noted) (see Figure 1)

| | | SN54ABT16600 | | SN74ABT16600 | | UNIT |
|--------------------|-----------------|------------------------------------|-----|--------------|-----|------|
| | | MIN | MAX | MIN | MAX | |
| f_{clock} | Clock frequency | 0 | 150 | 0 | 150 | MHz |
| t_w | Pulse duration | LEAB or LEBA high | | 2.5 | | ns |
| | | CLKAB or CLKBA high or low | | 3 | | |
| t_{su} | Setup time | A before CLKAB↓ or B before CLKBA↓ | | 3 | | ns |
| | | A before LEAB↓ or B before LEBA↓ | | 2.5 | | |
| | | CLKEN before CLK↓ | | 2.5 | | |
| t_h | Hold time | A after CLKAB↓ or B after CLKBA↓ | | 0 | | ns |
| | | A after LEAB↓ or B after LEBA↓ | | 2 | | |
| | | CLKEN after CLK↓ | | 1 | | |

switching characteristics over recommended ranges of supply voltage and operating free-air temperature, $C_L = 50$ pF (unless otherwise noted) (see Figure 1)

| PARAMETER | FROM (INPUT) | TO (OUTPUT) | $V_{CC} = 5$ V, $T_A = 25^\circ\text{C}$ | | | SN54ABT16600 | | SN74ABT16600 | | UNIT |
|------------------|----------------|-------------|---|-----|-----|--------------|-----|--------------|-----|------|
| | | | MIN | TYP | MAX | MIN | MAX | MIN | MAX | |
| f_{max} | | | 150 | | | 150 | | 150 | | MHz |
| t_{PLH} | A or B | B or A | 1.5 | 2.5 | 3.6 | 1.5 | 4.2 | 1.5 | 4 | ns |
| t_{PHL} | | | 1.5 | 3.2 | 4.5 | 1.5 | 5.1 | 1.5 | 4.9 | |
| t_{PLH} | LEAB or LEBA | B or A | 2 | 3.2 | 4.5 | 2 | 5.6 | 2 | 5 | ns |
| t_{PHL} | | | 2 | 3.4 | 4.5 | 2 | 5.4 | 2 | 5 | |
| t_{PLH} | CLKAB or CLKBA | B or A | 2 | 3.5 | 4.7 | 2 | 5.4 | 2 | 5.3 | ns |
| t_{PHL} | | | 2 | 3.5 | 4.3 | 2 | 5.2 | 2 | 5 | |
| t_{PZH} | OEAB or OEBA | B or A | 1.5 | 3.4 | 4.6 | 1.5 | 5.3 | 1.5 | 5.1 | ns |
| t_{PZL} | | | 2 | 3.8 | 4.7 | 2 | 5.6 | 2 | 5.4 | |
| t_{PHZ} | OEAB or OEBA | B or A | 2 | 4.5 | 5.4 | 2 | 6.6 | 2 | 6.2 | ns |
| t_{PLZ} | | | 1.5 | 3.4 | 4.7 | 1.5 | 5.8 | 1.5 | 5.4 | |

PRODUCT PREVIEW information concerns products in the formative or design phase of development. Characteristic data and other specifications are design goals. Texas Instruments reserves the right to change or discontinue these products without notice.

SN54ABT16600, SN74ABT16600 18-BIT UNIVERSAL BUS TRANSCEIVERS WITH 3-STATE OUTPUTS

SCBS209B – JUNE 1992 – REVISED JANUARY 1997

PARAMETER MEASUREMENT INFORMATION

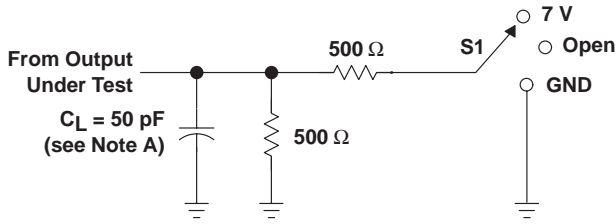

LOAD CIRCUIT

| TEST | S1 |
|-------------------|------|
| t_{PLH}/t_{PHL} | Open |
| t_{PLZ}/t_{PZL} | 7 V |
| t_{PHZ}/t_{PZH} | Open |

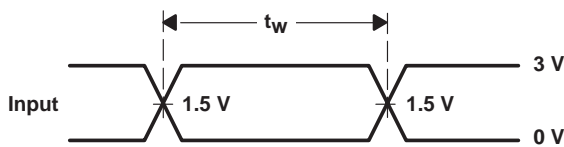

VOLTAGE WAVEFORMS
PULSE DURATION

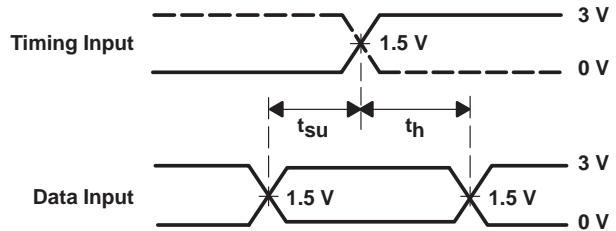

VOLTAGE WAVEFORMS
SETUP AND HOLD TIMES

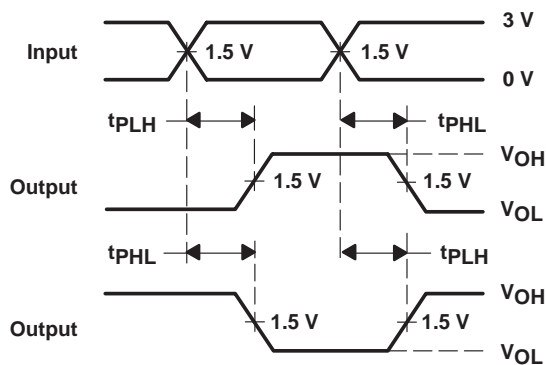

VOLTAGE WAVEFORMS
PROPAGATION DELAY TIMES
INVERTING AND NONINVERTING OUTPUTS

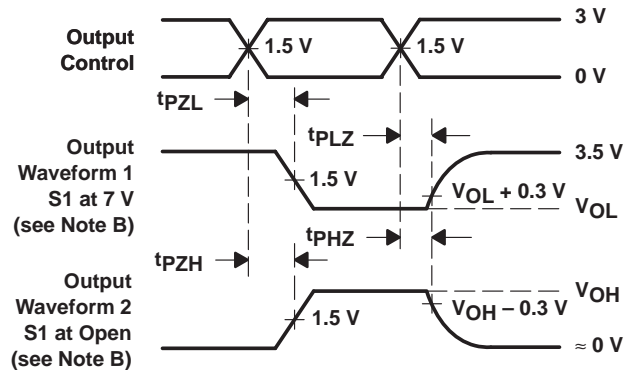

VOLTAGE WAVEFORMS
ENABLE AND DISABLE TIMES
LOW- AND HIGH-LEVEL ENABLING

- NOTES: A. C_L includes probe and jig capacitance.
 B. Waveform 1 is for an output with internal conditions such that the output is low except when disabled by the output control. Waveform 2 is for an output with internal conditions such that the output is high except when disabled by the output control.
 C. All input pulses are supplied by generators having the following characteristics: PRR \leq 10 MHz, $Z_O = 50 \Omega$, $t_r \leq 2.5$ ns, $t_f \leq 2.5$ ns.
 D. The outputs are measured one at a time with one transition per measurement.

Figure 1. Load Circuit and Voltage Waveforms



PACKAGING INFORMATION

| Orderable Device | Status (1) | Package Type | Package Drawing | Pins | Package Qty | Eco Plan (2) | Lead/Ball Finish (6) | MSL Peak Temp (3) | Op Temp (°C) | Device Marking (4/5) | Samples |
|------------------|---------------|--------------|-----------------|------|-------------|-----------------|-------------------------|----------------------|--------------|-------------------------|---------|
| SN74ABT16600DL | OBSOLETE | SSOP | DL | 56 | | TBD | Call TI | Call TI | -40 to 85 | | |
| SN74ABT16600DLG4 | OBSOLETE | SSOP | DL | 56 | | TBD | Call TI | Call TI | -40 to 85 | | |

(1) The marketing status values are defined as follows:

ACTIVE: Product device recommended for new designs.

LIFEBUY: TI has announced that the device will be discontinued, and a lifetime-buy period is in effect.

NRND: Not recommended for new designs. Device is in production to support existing customers, but TI does not recommend using this part in a new design.

PREVIEW: Device has been announced but is not in production. Samples may or may not be available.

OBSOLETE: TI has discontinued the production of the device.

(2) Eco Plan - The planned eco-friendly classification: Pb-Free (RoHS), Pb-Free (RoHS Exempt), or Green (RoHS & no Sb/Br) - please check <http://www.ti.com/productcontent> for the latest availability information and additional product content details.

TBD: The Pb-Free/Green conversion plan has not been defined.

Pb-Free (RoHS): TI's terms "Lead-Free" or "Pb-Free" mean semiconductor products that are compatible with the current RoHS requirements for all 6 substances, including the requirement that lead not exceed 0.1% by weight in homogeneous materials. Where designed to be soldered at high temperatures, TI Pb-Free products are suitable for use in specified lead-free processes.

Pb-Free (RoHS Exempt): This component has a RoHS exemption for either 1) lead-based flip-chip solder bumps used between the die and package, or 2) lead-based die adhesive used between the die and leadframe. The component is otherwise considered Pb-Free (RoHS compatible) as defined above.

Green (RoHS & no Sb/Br): TI defines "Green" to mean Pb-Free (RoHS compatible), and free of Bromine (Br) and Antimony (Sb) based flame retardants (Br or Sb do not exceed 0.1% by weight in homogeneous material)

(3) MSL, Peak Temp. - The Moisture Sensitivity Level rating according to the JEDEC industry standard classifications, and peak solder temperature.

(4) There may be additional marking, which relates to the logo, the lot trace code information, or the environmental category on the device.

(5) Multiple Device Markings will be inside parentheses. Only one Device Marking contained in parentheses and separated by a "-" will appear on a device. If a line is indented then it is a continuation of the previous line and the two combined represent the entire Device Marking for that device.

(6) Lead/Ball Finish - Orderable Devices may have multiple material finish options. Finish options are separated by a vertical ruled line. Lead/Ball Finish values may wrap to two lines if the finish value exceeds the maximum column width.

Important Information and Disclaimer: The information provided on this page represents TI's knowledge and belief as of the date that it is provided. TI bases its knowledge and belief on information provided by third parties, and makes no representation or warranty as to the accuracy of such information. Efforts are underway to better integrate information from third parties. TI has taken and continues to take reasonable steps to provide representative and accurate information but may not have conducted destructive testing or chemical analysis on incoming materials and chemicals. TI and TI suppliers consider certain information to be proprietary, and thus CAS numbers and other limited information may not be available for release.

In no event shall TI's liability arising out of such information exceed the total purchase price of the TI part(s) at issue in this document sold by TI to Customer on an annual basis.



Distributor of Texas Instruments: Excellent Integrated System Limited

Datasheet of SN74ABT16600DLR - IC UNIV BUS TXRX 18BIT 56SSOP

Contact us: sales@integrated-circuit.com Website: www.integrated-circuit.com

PACKAGE OPTION ADDENDUM

IMPORTANT NOTICE

Texas Instruments Incorporated and its subsidiaries (TI) reserve the right to make corrections, enhancements, improvements and other changes to its semiconductor products and services per JESD46, latest issue, and to discontinue any product or service per JESD48, latest issue. Buyers should obtain the latest relevant information before placing orders and should verify that such information is current and complete. All semiconductor products (also referred to herein as "components") are sold subject to TI's terms and conditions of sale supplied at the time of order acknowledgment.

TI warrants performance of its components to the specifications applicable at the time of sale, in accordance with the warranty in TI's terms and conditions of sale of semiconductor products. Testing and other quality control techniques are used to the extent TI deems necessary to support this warranty. Except where mandated by applicable law, testing of all parameters of each component is not necessarily performed.

TI assumes no liability for applications assistance or the design of Buyers' products. Buyers are responsible for their products and applications using TI components. To minimize the risks associated with Buyers' products and applications, Buyers should provide adequate design and operating safeguards.

TI does not warrant or represent that any license, either express or implied, is granted under any patent right, copyright, mask work right, or other intellectual property right relating to any combination, machine, or process in which TI components or services are used. Information published by TI regarding third-party products or services does not constitute a license to use such products or services or a warranty or endorsement thereof. Use of such information may require a license from a third party under the patents or other intellectual property of the third party, or a license from TI under the patents or other intellectual property of TI.

Reproduction of significant portions of TI information in TI data books or data sheets is permissible only if reproduction is without alteration and is accompanied by all associated warranties, conditions, limitations, and notices. TI is not responsible or liable for such altered documentation. Information of third parties may be subject to additional restrictions.

Resale of TI components or services with statements different from or beyond the parameters stated by TI for that component or service voids all express and any implied warranties for the associated TI component or service and is an unfair and deceptive business practice. TI is not responsible or liable for any such statements.

Buyer acknowledges and agrees that it is solely responsible for compliance with all legal, regulatory and safety-related requirements concerning its products, and any use of TI components in its applications, notwithstanding any applications-related information or support that may be provided by TI. Buyer represents and agrees that it has all the necessary expertise to create and implement safeguards which anticipate dangerous consequences of failures, monitor failures and their consequences, lessen the likelihood of failures that might cause harm and take appropriate remedial actions. Buyer will fully indemnify TI and its representatives against any damages arising out of the use of any TI components in safety-critical applications.

In some cases, TI components may be promoted specifically to facilitate safety-related applications. With such components, TI's goal is to help enable customers to design and create their own end-product solutions that meet applicable functional safety standards and requirements. Nonetheless, such components are subject to these terms.

No TI components are authorized for use in FDA Class III (or similar life-critical medical equipment) unless authorized officers of the parties have executed a special agreement specifically governing such use.

Only those TI components which TI has specifically designated as military grade or "enhanced plastic" are designed and intended for use in military/aerospace applications or environments. Buyer acknowledges and agrees that any military or aerospace use of TI components which have **not** been so designated is solely at the Buyer's risk, and that Buyer is solely responsible for compliance with all legal and regulatory requirements in connection with such use.

TI has specifically designated certain components as meeting ISO/TS16949 requirements, mainly for automotive use. In any case of use of non-designated products, TI will not be responsible for any failure to meet ISO/TS16949.

Products

| | |
|------------------------------|--|
| Audio | www.ti.com/audio |
| Amplifiers | amplifier.ti.com |
| Data Converters | dataconverter.ti.com |
| DLP® Products | www.dlp.com |
| DSP | dsp.ti.com |
| Clocks and Timers | www.ti.com/clocks |
| Interface | interface.ti.com |
| Logic | logic.ti.com |
| Power Mgmt | power.ti.com |
| Microcontrollers | microcontroller.ti.com |
| RFID | www.ti-rfid.com |
| OMAP Applications Processors | www.ti.com/omap |
| Wireless Connectivity | www.ti.com/wirelessconnectivity |

Applications

| | |
|-------------------------------|--|
| Automotive and Transportation | www.ti.com/automotive |
| Communications and Telecom | www.ti.com/communications |
| Computers and Peripherals | www.ti.com/computers |
| Consumer Electronics | www.ti.com/consumer-apps |
| Energy and Lighting | www.ti.com/energy |
| Industrial | www.ti.com/industrial |
| Medical | www.ti.com/medical |
| Security | www.ti.com/security |
| Space, Avionics and Defense | www.ti.com/space-avionics-defense |
| Video and Imaging | www.ti.com/video |

TI E2E Community

e2e.ti.com