



Distributor of Texas Instruments: Excellent Integrated System Limited

Datasheet of SN74ABT5401DW - IC LINE/MEMORY DVR 11BIT 28SOIC

Contact us: sales@integrated-circuit.com Website: www.integrated-circuit.com

Excellent Integrated System Limited

Stocking Distributor

Click to view price, real time Inventory, Delivery & Lifecycle Information:

[Texas Instruments](#)
[SN74ABT5401DW](#)

For any questions, you can email us directly:

sales@integrated-circuit.com

SN54ABT5401, SN74ABT5401
11-BIT LINE/MEMORY DRIVERS
WITH 3-STATE OUTPUTS

SCBS235B – JUNE 1992 – REVISED JANUARY 1997

- Output Ports Have Equivalent 25-Ω Series Resistors, So No External Resistors Are Required
- State-of-the-Art EPIC-II B™ BiCMOS Design Significantly Reduces Power Dissipation
- Latch-Up Performance Exceeds 500 mA Per JEDEC Standard JESD-17
- Typical V_{OLP} (Output Ground Bounce) < 1 V at V_{CC} = 5 V, T_A = 25°C
- Typical V_{OLV} (Output Undershoot) < 0.5 V at V_{CC} = 5 V, T_A = 25°C
- Package Options Include Plastic Small-Outline (DW) Package, Ceramic Chip Carriers (FK), and DIPs (JT)

description

These 11-bit buffers and line drivers are designed specifically to improve both the performance and density of 3-state memory address drivers, clock drivers, and bus-oriented receivers and transmitters.

The 3-state control gate is a 2-input AND gate with active-low inputs so that if either output-enable ($\overline{OE1}$ or $\overline{OE2}$) input is high, all 11 outputs are in the high-impedance state. These devices provide inverted data.

The outputs, which are designed to source or sink up to 12 mA, include equivalent 25-Ω series resistors to reduce overshoot and undershoot.

To ensure the high-impedance state during power up or power down, \overline{OE} should be tied to V_{CC} through a pullup resistor; the minimum value of the resistor is determined by the current-sinking capability of the driver.

The SN54ABT5401 is characterized for operation over the full military temperature range of -55°C to 125°C. The SN74ABT5401 is characterized for operation from -40°C to 85°C.

SN54ABT5401 . . . JT PACKAGE
 SN74ABT5401 . . . DW PACKAGE
 (TOP VIEW)

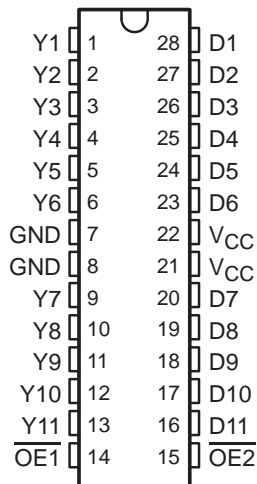

SN54ABT5401 . . . FK PACKAGE
 (TOP VIEW)

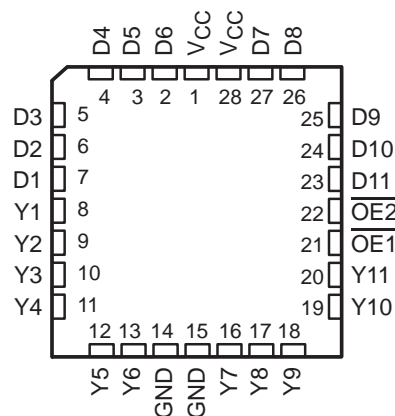

FUNCTION TABLE

INPUTS			OUTPUT
$\overline{OE1}$	$\overline{OE2}$	D	Y
L	L	L	H
L	L	H	L
H	X	X	Z
X	H	X	Z



Please be aware that an important notice concerning availability, standard warranty, and use in critical applications of Texas Instruments semiconductor products and disclaimers thereto appears at the end of this data sheet.

EPIC-II B is a trademark of Texas Instruments Incorporated.

UNLESS OTHERWISE NOTED this document contains PRODUCTION DATA information current as of publication date. Products conform to specifications per the terms of Texas Instruments standard warranty. Production processing does not necessarily include testing of all parameters.



POST OFFICE BOX 655303 • DALLAS, TEXAS 75265

Copyright © 1997, Texas Instruments Incorporated

SN54ABT5401, SN74ABT5401
11-BIT LINE/MEMORY DRIVERS
WITH 3-STATE OUTPUTS

SCBS235B – JUNE 1992 – REVISED JANUARY 1997

logic symbol†

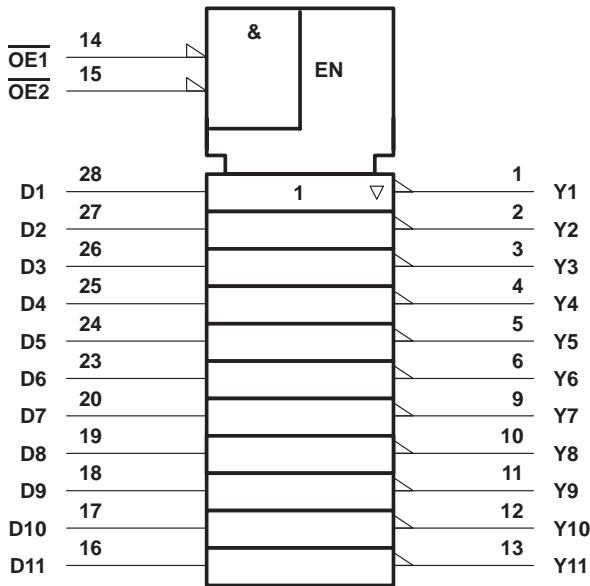

logic diagram (positive logic)

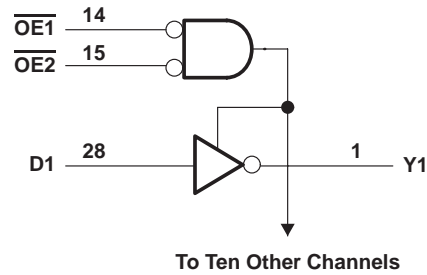

† This symbol is in accordance with ANSI/IEEE Std 91-1984 and IEC Publication 617-12.

Pin numbers shown are for the DW and JT packages.

absolute maximum ratings over operating free-air temperature range (unless otherwise noted)‡

Supply voltage range, V_{CC}	-0.5 V to 7 V
Input voltage range, V_I (see Note 1)	-0.5 V to 7 V
Voltage range applied to any output in the high or power-off state, V_O	-0.5 V to 5.5 V
Current into any output in the low state, I_O	30 mA
Input clamp current, I_{IK} ($V_I < 0$)	-18 mA
Output clamp current, I_{OK} ($V_O < 0$)	-50 mA
Package thermal impedance, θ_{JA} (see Note 2): DW package	78°C/W
Storage temperature range, T_{stg}	-65°C to 150°C

‡ Stresses beyond those listed under "absolute maximum ratings" may cause permanent damage to the device. These are stress ratings only, and functional operation of the device at these or any other conditions beyond those indicated under "recommended operating conditions" is not implied. Exposure to absolute-maximum-rated conditions for extended periods may affect device reliability.

- NOTES: 1. The input and output negative-voltage ratings may be exceeded if the input and output clamp-current ratings are observed.
 2. The package thermal impedance is calculated in accordance with EIA/JEDEC Std JESD51.

SN54ABT5401, SN74ABT5401
11-BIT LINE/MEMORY DRIVERS
WITH 3-STATE OUTPUTS
 SCBS235B – JUNE 1992 – REVISED JANUARY 1997

recommended operating conditions (see Note 3)

		SN54ABT5401		SN74ABT5401		UNIT
		MIN	MAX	MIN	MAX	
V _{CC}	Supply voltage	4.5	5.5	4.5	5.5	V
V _{IH}	High-level input voltage	2		2		V
V _{IL}	Low-level input voltage		0.8		0.8	V
V _I	Input voltage	0	V _{CC}	0	V _{CC}	V
I _{OH}	High-level output current		-12		-12	mA
I _{OL}	Low-level output current		12		12	mA
Δt/Δv	Input transition rise or fall rate	Outputs enabled		10	10	ns/V
T _A	Operating free-air temperature	-55	125	-40	85	°C

NOTE 3: Unused inputs must be held high or low to prevent them from floating.

electrical characteristics over recommended operating free-air temperature range (unless otherwise noted)

PARAMETER	TEST CONDITIONS	T _A = 25°C			SN54ABT5401		SN74ABT5401		UNIT	
		MIN	TYP†	MAX	MIN	MAX	MIN	MAX		
V _{IK}	V _{CC} = 4.5 V, I _I = -18 mA			-1.2		-1.2		-1.2	V	
V _{OH}	V _{CC} = 4.5 V, I _{OH} = -1 mA	3.35	3.7		3.3		3.35		V	
	V _{CC} = 5 V, I _{OH} = -1 mA	3.85	4.2		3.8		3.85			
	V _{CC} = 4.5 V	I _{OH} = -3 mA				3		3.1		
		I _{OH} = -12 mA	2.6					2.6		
V _{OL}	V _{CC} = 4.5 V	I _{OL} = 8 mA				0.8		0.65	V	
		I _{OL} = 12 mA						0.8		
V _{hys}			100						mV	
I _I	V _{CC} = 5.5 V, V _I = V _{CC} or GND			±1		±1		±1	μA	
I _{OZH}	V _{CC} = 5.5 V, V _O = 2.7 V			50		50		50	μA	
I _{OZL}	V _{CC} = 5.5 V, V _O = 0.5 V			-50		-50		-50	μA	
I _{off}	V _{CC} = 0, V _I or V _O ≤ 4.5 V			±100				±100	μA	
I _{CEX}	V _{CC} = 5.5 V, V _O = 5.5 V Outputs high			50		50		50	μA	
I _O	V _{CC} = 5.5 V, V _O = 2.5 V	-25	-45	-100	-25	-100	-25	-100	mA	
I _{OS} ‡	V _{CC} = 5.5 V, V _O = 0	-50		-200	-50	-200	-50	-200	mA	
I _{CC}	V _{CC} = 5.5 V, I _O = 0, V _I = V _{CC} or GND	Outputs high	5	50	50		50		μA	
		Outputs low	36	45	45		45		mA	
		Outputs disabled	1	50	50		50		μA	
ΔI _{CC} §	Data inputs V _{CC} = 5.5 V, One input at 3.4 V, Other inputs at V _{CC} or GND	Outputs enabled		1.5	1.5		1.5		mA	
		Outputs disabled		0.05	0.05		0.05			
	Control inputs V _{CC} = 5.5 V, One input at 3.4 V, Other inputs at V _{CC} or GND		1.5	1.5		1.5		1.5		
C _i	V _I = 2.5 V or 0.5 V		3						pF	
C _o	V _O = 2.5 V or 0.5 V		8						pF	

† All typical values are at V_{CC} = 5 V.

‡ Not more than one output should be tested at a time, and the duration of the test should not exceed one second.

§ This is the increase in supply current for each input that is at the specified TTL voltage level rather than V_{CC} or GND.

PRODUCT PREVIEW information concerns products in the formative or design phase of development. Characteristic data and other specifications are design goals. Texas Instruments reserves the right to change or discontinue these products without notice.



SN54ABT5401, SN74ABT5401
11-BIT LINE/MEMORY DRIVERS
WITH 3-STATE OUTPUTS

SCBS235B – JUNE 1992 – REVISED JANUARY 1997

switching characteristics over recommended ranges of supply voltage and operating free-air temperature, $C_L = 50 \text{ pF}$ (unless otherwise noted) (see Figure 1)

PARAMETER	FROM (INPUT)	TO (OUTPUT)	$V_{CC} = 5 \text{ V}, T_A = 25^\circ\text{C}$			SN54ABT5401		SN74ABT5401		UNIT
			MIN	TYP	MAX	MIN	MAX	MIN	MAX	
t_{PLH}	D	Y	2	4.5	6.1	2	7	2	6.9	ns
t_{PHL}			1.5	4.4	5.2	1.5	5.9	1.5	5.7	
t_{PZH}	\overline{OE}	Y	2.5	5.7	6.6	2.5	8.6	2.5	8.5	ns
t_{PZL}			2	4.4	5.5	2	6.9	2	6.8	
t_{PHZ}	\overline{OE}	Y	1.5	3.6	4.4	1.5	5.5	1.5	5.2	ns
t_{PLZ}			1.5	4.2	5.4	1.5	7.4	1.5	6.9	

SN54ABT5401, SN74ABT5401
11-BIT LINE/MEMORY DRIVERS
WITH 3-STATE OUTPUTS

SCBS235B - JUNE 1992 - REVISED JANUARY 1997

PARAMETER MEASUREMENT INFORMATION

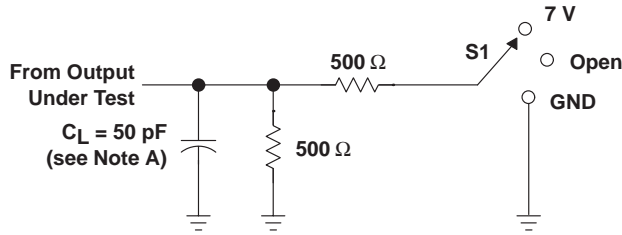

TEST	S1
t_{PLH}/t_{PHL}	Open
t_{PLZ}/t_{PZL}	7 V
t_{PHZ}/t_{PZH}	Open

LOAD CIRCUIT

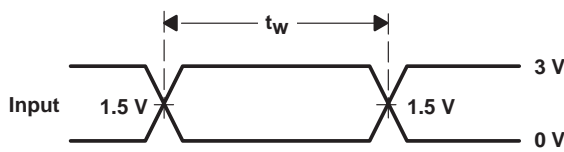

VOLTAGE WAVEFORMS
PULSE DURATION

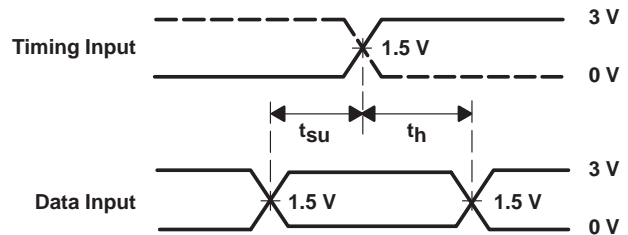

VOLTAGE WAVEFORMS
SETUP AND HOLD TIMES

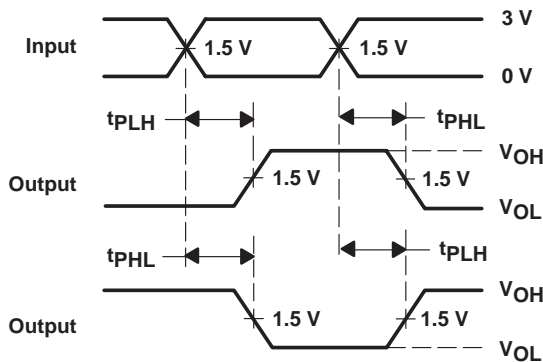

VOLTAGE WAVEFORMS
PROPAGATION DELAY TIMES
INVERTING AND NONINVERTING OUTPUTS

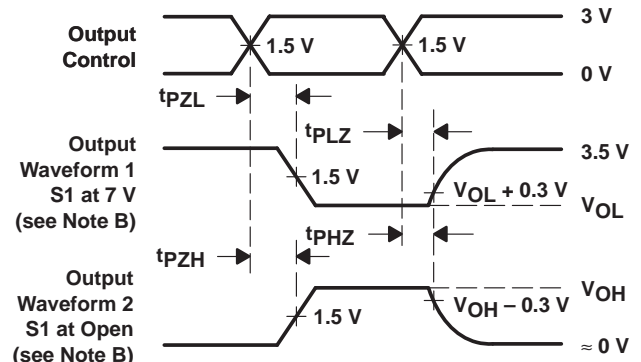

VOLTAGE WAVEFORMS
ENABLE AND DISABLE TIMES
LOW- AND HIGH-LEVEL ENABLING

- NOTES: A. C_L includes probe and jig capacitance.
 B. Waveform 1 is for an output with internal conditions such that the output is low except when disabled by the output control. Waveform 2 is for an output with internal conditions such that the output is high except when disabled by the output control.
 C. All input pulses are supplied by generators having the following characteristics: $PRR \leq 10 \text{ MHz}$, $Z_O = 50 \Omega$, $t_r \leq 2.5 \text{ ns}$, $t_f \leq 2.5 \text{ ns}$
 D. The outputs are measured one at a time with one transition per measurement.

Figure 1. Load Circuit and Voltage Waveforms

IMPORTANT NOTICE

Texas Instruments and its subsidiaries (TI) reserve the right to make changes to their products or to discontinue any product or service without notice, and advise customers to obtain the latest version of relevant information to verify, before placing orders, that information being relied on is current and complete. All products are sold subject to the terms and conditions of sale supplied at the time of order acknowledgement, including those pertaining to warranty, patent infringement, and limitation of liability.

TI warrants performance of its semiconductor products to the specifications applicable at the time of sale in accordance with TI's standard warranty. Testing and other quality control techniques are utilized to the extent TI deems necessary to support this warranty. Specific testing of all parameters of each device is not necessarily performed, except those mandated by government requirements.

CERTAIN APPLICATIONS USING SEMICONDUCTOR PRODUCTS MAY INVOLVE POTENTIAL RISKS OF DEATH, PERSONAL INJURY, OR SEVERE PROPERTY OR ENVIRONMENTAL DAMAGE ("CRITICAL APPLICATIONS"). TI SEMICONDUCTOR PRODUCTS ARE NOT DESIGNED, AUTHORIZED, OR WARRANTED TO BE SUITABLE FOR USE IN LIFE-SUPPORT DEVICES OR SYSTEMS OR OTHER CRITICAL APPLICATIONS. INCLUSION OF TI PRODUCTS IN SUCH APPLICATIONS IS UNDERSTOOD TO BE FULLY AT THE CUSTOMER'S RISK.

In order to minimize risks associated with the customer's applications, adequate design and operating safeguards must be provided by the customer to minimize inherent or procedural hazards.

TI assumes no liability for applications assistance or customer product design. TI does not warrant or represent that any license, either express or implied, is granted under any patent right, copyright, mask work right, or other intellectual property right of TI covering or relating to any combination, machine, or process in which such semiconductor products or services might be or are used. TI's publication of information regarding any third party's products or services does not constitute TI's approval, warranty or endorsement thereof.