

## Excellent Integrated System Limited

Stocking Distributor

Click to view price, real time Inventory, Delivery & Lifecycle Information:

[Harwin Inc.](#)  
[R40-4000502](#)

For any questions, you can email us directly:  
[sales@integrated-circuit.com](mailto:sales@integrated-circuit.com)

# Customer Information Sheet

DRAWING No.: R40-400XX02 SHEET 2 OF 2 IF IN DOUBT - ASK © NOT TO SCALE THIRD ANGLE PROJECTION ALL DIMENSIONS IN mm

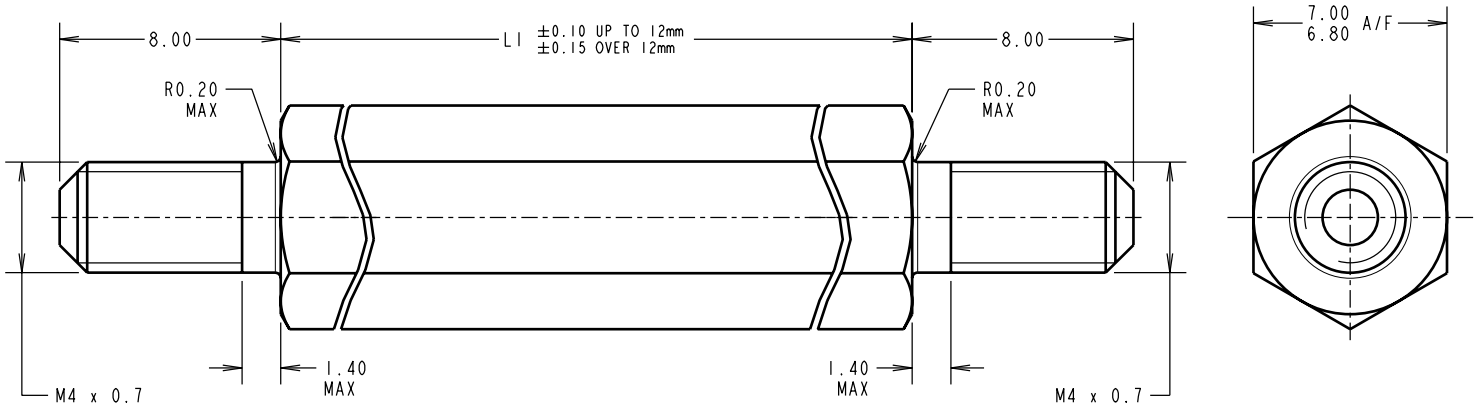

PART No.	LI	PART No.	LI
R40-4000502	5.00	R40-4001802	18.00
R40-4000602	6.00	R40-4002002	20.00
R40-4000802	8.00	R40-4002502	25.00
R40-4001002	10.00		
R40-4001202	12.00		
R40-4001402	14.00		
R40-4001602	16.00		

ORDER CODE: **R40-400XX02**  
 LENGTH LI IN mm

SF	4	10.10.08	10174
NAME	ISS.	DATE	C/NOTE
APPROVED:		SF	
CHECKED:		MGP	
DRAWN:		S.FLOWER	
CUSTOMER REF.:			
ASSEMBLY DRG:			

**HARWIN**

HARWIN USA  
 TEL: 603 893 5376  
 FAX: 603 893 5396  
 mis@harwin.com

HARWIN Europe (UK)  
 TEL: 023 9231 4545  
 FAX: 023 9231 4590  
 mis@harwin.co.uk

HARWIN Asia  
 TEL: +65 6 779 4909  
 FAX: +65 6 779 3868  
 mis@harwin.com.sg

THIS DRAWING AND ANY INFORMATION OR DESCRIPTIVE MATTER SET OUT HEREON ARE CONFIDENTIAL AND COPYRIGHT PROPERTY OF THE HARWIN GROUP AND MUST NOT BE DISCLOSED, LOANED, COPIED OR USED FOR MANUFACTURING, TENDERING OR FOR ANY OTHER PURPOSE WITHOUT THEIR WRITTEN PERMISSION.

TOLERANCES  
 X. = ±1mm  
 X.X = ±0.25mm  
 X.XX = ±0.10mm  
 X.XXX = ±0.01mm  
 ANGLES = ±5°  
 UNLESS STATED

MATERIAL: BRASS CW614N M TO BS EN 12164 (CuZn39Pb3)  
 FINISH: NICKEL  
 S/AREA: mm<sup>2</sup>

TITLE: M4 HEXAGONAL MALE/MALE SPACER

DRAWING NUMBER: R40-400XX02

SHT 2 OF 2