



Distributor of E-T-A: Excellent Integrated System Limited

Datasheet of 8345-B01A-L6M2-DB1B1B-X8345-R-24010001M-15A - CIR BRKR MAG-HYDR
15A 80VDC

Contact us: sales@integrated-circuit.com Website: www.integrated-circuit.com

Excellent Integrated System Limited

Stocking Distributor

Click to view price, real time Inventory, Delivery & Lifecycle Information:

[E-T-A](#)

[8345-B01A-L6M2-DB1B1B-X8345-R-24010001M-15A](#)

For any questions, you can email us directly:

sales@integrated-circuit.com



Magnetic and Hydraulic-Magnetic Circuit Breaker 8345-...

Description

Single or multipole hydraulic-magnetic circuit breakers with trip-free mechanism and toggle actuation. A choice of switching characteristics ensures suitability for a wide range of applications. Industry standard dimensions and panel mounting. Auxiliary contacts optional. Low temperature sensitivity at rated load.

Approved to CBE standard EN 60934 (IEC 60934) S-type HM CBE.

Typical applications

In the business fields Communication and Transport: power supplies, switchgear, instrumentation and process control engineering.

Standard current ratings and typical internal resistance values

Current rating (A)	Trip curves and internal resistance (Ω) per pole	
	K1, M1, T1,	K2, M2, T2
0.05	452	376
0.1	100	94
1	0.95	0.90
2	0.26	0.20
3	0.10	0.10
5	0.042	0.040
10	< 0.02	< 0.02
15	< 0.02	< 0.02
20	< 0.02	< 0.02
25	< 0.02	< 0.02
30	< 0.02	< 0.02
40	< 0.01	< 0.01
50	< 0.01	< 0.01
60	< 0.01	< 0.01
80	< 0.01	< 0.01
100	< 0.01	< 0.01
125	< 0.01	< 0.01

Interrupting capacity to EN 60934, UL 489 and UL 1077

IEC 60934 – test series E

voltage	number of poles	I_N max. (A)	I_{cn} (A)
DC 80 V	1 + 2	0.02...125	10,000
AC 240/415 V	1 - 6	0.02...80	$6 \times I_N$
AC 240 V	1	0.02...20	5,000

UL 489 – test sequence Z

voltage	number of poles	I_N max. (A)	I_{cn} (A)
DC 80 V	1 + 2	0.5...125	10,000
AC 120 V	1	0.5...80	5,000
AC 120/240 V	1	0.5...80	5,000
AC 240 V	1 (2)	0.5...20	5,000

UL 1077

voltage	number of poles	I_N max. (A)	I_{cn} (A)
DC 80 V	1 + 2	0.02...125	10,000
AC 277/480 V	1 - 6	0.02...70	5,000

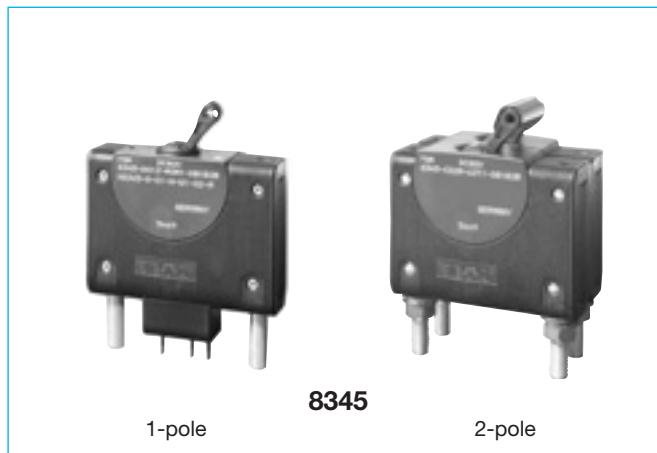

Technical data

Voltage rating	3 AC 415 V; AC 277/480 V; AC 120/240 V; AC 240 V; DC 80 V,
Current rating range	0.05...125 A single and multipole 150...180 A single pole, two poles connected in parallel higher ratings upon request
Auxiliary circuit	AC 240 V 6 A; DC 28 V 3 A DC 65 V 1 A; DC 80 V 0.5 A
Typical life	10,000 operations at $1 \times I_N$
Ambient temperature	-40...+85 °C (-40...+185 °F)
Insulation co-ordination (IEC 60664)	2.5 kV/2 reinforced insulation in operating area
Dielectric strength	test voltage
operating area	AC 3,000 V
pole to pole	AC 1,500 V
main to auxiliary circuit	AC 3,000 V
switching to trip circuit	AC 1,500 V
Insulation resistance	> 100 M Ω (DC 500 V)
Degree of protection (IEC 60529)	operating area IP40 terminal area IP00
Vibration	
with toggle down:	10 g (57-2000 Hz) ± 0.76 mm (10-57Hz) at $0.9 I_N$
directions 1, 2, 3, 4, 5:	10 g at $1 \times I_N$
with curves F1, F2:	10 g at $0.8 \times I_N$ in all planes. (57-2000 Hz) ± 0.76 mm (10-57 Hz) to IEC 60068-2-6, test Fc 10 frequency cycles/axis
Shock	
directions 1, 2, 3, 4, 5:	100 g (11 ms) at $1 \times I_N$,
direction 6:	100 g (11 ms) at $0.8 \times I_N$,
with curves F1, F2:	100 g (11 ms) at $0.8 \times I_N$ to IEC 60068-2-27, test Ea
Corrosion	96 hours at 5% salt mist, to IEC 60068-2-11, test Ka
Humidity	240 hours at 95 % RH, to IEC 60068-2-3, test Ca
Mass	approx. 90 - 120 g per pole depending on version

Approvals

VDE (EN 60934)	1- to 6-pole
UL 489	
UL 1077	1- to 6-pole
CCC	1- to 4-pole



Magnetic and Hydraulic-Magnetic Circuit Breaker 8345-...

Ordering information

Type No.

8345

Mounting
B flange mounting, with rectangular aperture with mounting nut 6-32UNC

C flange mounting, with rectangular aperture with mounting nut M3

E flange mounting, with round aperture with mounting nut 6-32UNC

F flange mounting, with round aperture with mounting nut M3

Configuration
0 without barrier

1 with small barrier

2 with large barrier (request for multipole AC applications with approvals to UL 489, UL 1077, IEC)

Number of poles
0 single pole unprotected

1 single pole protected

2 two pole protected

3 three pole protected

4 four pole protected

P one pole protected, two poles connected in parallel characteristic curves E/H/R upon request

Q one pole protected, three poles connected in parallel characteristic curves E/H/R upon request

R one pole protected, four poles connected in parallel characteristic curves E/H/R upon request

S one pole protected, five poles connected in parallel characteristic curves E/H/R upon request

Actuator configuration
A all poles with standard toggle

B reduced number of standard toggles

Z without actuator

Terminal design
L screw terminals M5 ≤ 50 A

M solder terminals ≤ 75 A

P blade terminals ≤ 35 A

R round connectors 6 mm

S stud terminals M5 ≤ 60 A

T stud terminals 10-32UNF-3A ≤ 60 A

U stud terminals M6 ≤ 125 A

V stud terminals 1/4-20UNC-3A ≤ 125 A

W laminated round terminals ≤ 125 A

Terminal hardware
0 without

3 with washer and nut

6 Phillips screws

Characteristic curve
K1 short delay DC

K2 short delay AC

M0 medium delay AC/DC

M1 medium delay DC

M2 medium delay AC

Q0 switch only

T1 long delay DC

T2 long delay AC

Illumination

- without

Version
D standard

Colour configuration
B1 black actuator

B2 white actuator

B8 blue actuator

Marking

front plate actuator base

A1 without without

A2 I_N without

A3 I_N, characteristic curve without

A4 I_N, characteristic curve, without
 wiring diagram on side

B1 without ON-OFF

B2 I_N ON-OFF

B3 I_N ON-OFF
 characteristic curve

B4 I_N, characteristic curve, ON-OFF
 wiring diagram on side

8345 - C 0 1 A - U 3 M1 - . D B1 A1 ...

8345 - C 0 1 A - U 3 M1 - . D B1 A1

Rated voltage
B AC or ≤ 80 V DC

C DC ≤ 80 V

AC ≤ 277 V

 (only for configurations
 0 and 1)

Current ratings

0.05...125 A

 higher current ratings
 upon request

Approvals (optional)
V UL 489

8345 - C 0 1 A - U 3 M1 - . D B1 A1 B - 60 A - . ordering example

Remote trip coil available to special order!

Ordering information for auxiliary contact module

Type number

X8345

Module
S auxiliary contact module

Auxiliary contacts
01 in all poles

02 in pole 1 only

03 in poles 1 + 3 only

04 in pole 2 only

Auxiliary contact version
H auxiliary contacts standard, gold-flushed
 (asymmetrical terminals not for UL 489)

K auxiliary contacts, tin-plated (symmetrical terminals)

Auxiliary contact function
W1 1 changeover

W2 2 changeover

Terminal design
02 microswitch with blade terminals
 DIN 46244-A2.8-0.5

M mounted to base unit

X8345 - S 01 H W1 02 M ordering example

Dimensions

Mounting version B/C

Flange mounting rectangular aperture

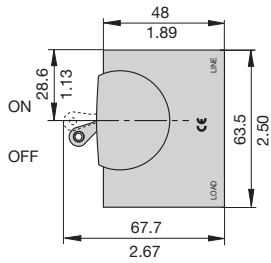

number of poles 1 to 4
pole 1 2 3 4

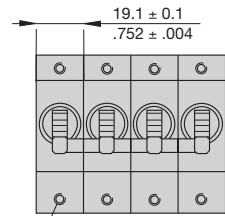

mounting thread M3 or 6-32
all dimensions referred to the top edge
mounting depth 4.2 mm/.165 in.
max. insertion depth 5.5 mm
max. tightening torque 0.33 Nm

Cut-out dimensions:

1-pole

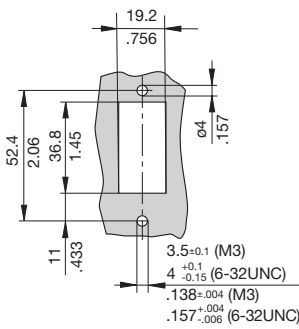

multipole

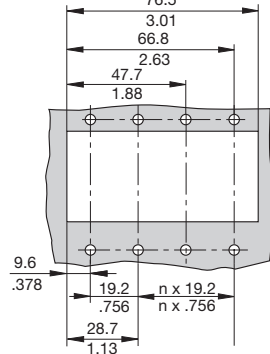

Mounting version E/F

Flange mounting round aperture

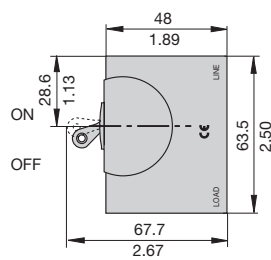

number of poles 1 to 4
pole 1 2 3 4

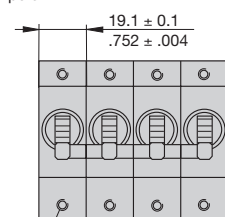

mounting thread M3 or 6-32
all dimensions referred to the top edge
mounting depth 4.2 mm/.165 in.
max. insertion depth 5.5 mm
max. tightening torque 0.33 Nm

Cut-out dimensions:

1-pole

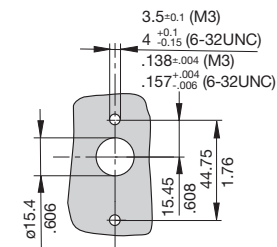

4-pole

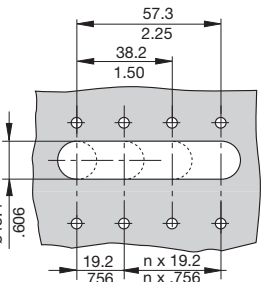

Installation drawing

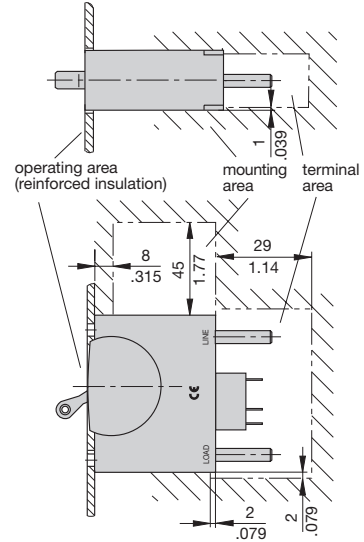

Actuator configuration

A 1 toggle per pole, mounting version B/C

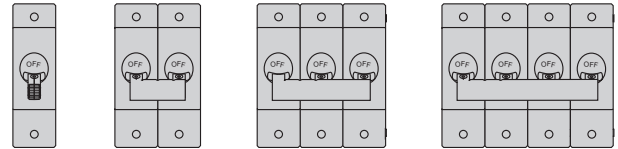

B reduced number of toggles per unit, mounting version B/C

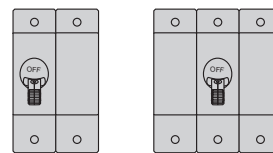

Z without toggles

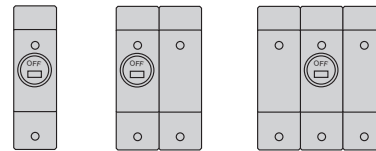

A 1 toggle per pole, mounting version E/F

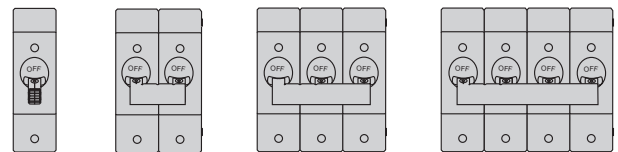

B reduced number of toggles per unit, mounting version E/F

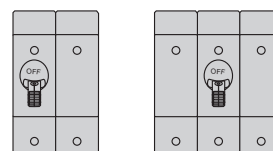

Terminal design / Dimensions

P - with blade terminals

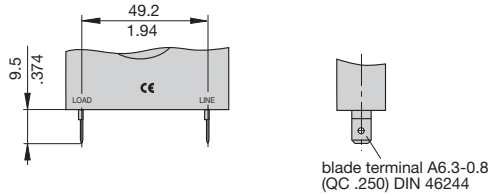

L - with screw terminals

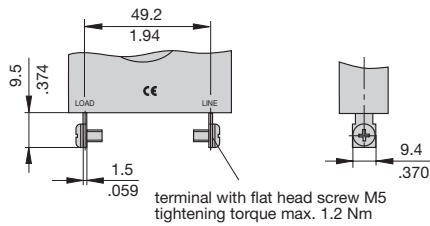

M - with solder terminals

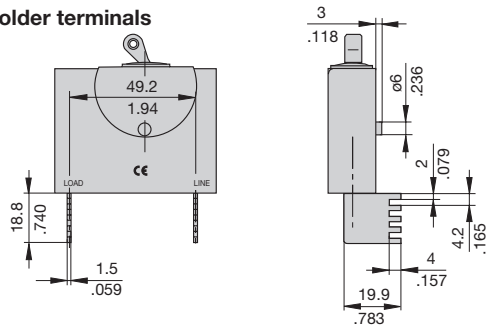

R - round connectors D= 6 mm (dia .236) (version H) asymmetrical terminals (not for UL 489)

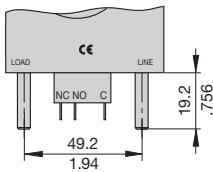

S/U/T/V - with auxiliary contacts (version H) asymmetrical terminals (not for UL 489)

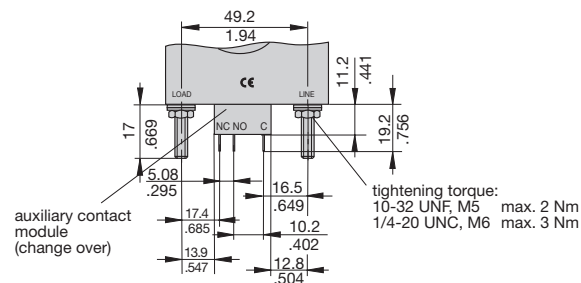

auxiliary contacts version K symmetrical terminals

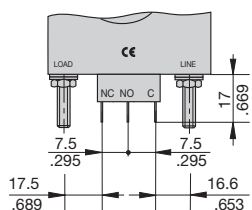

W - laminated round terminals

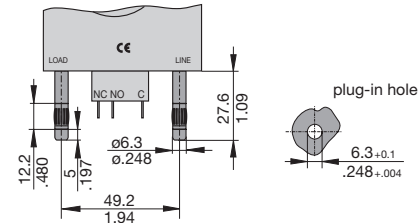

Number of poles / Dimensions

P 1-pole protected, 2-poles connected in parallel for rating currents from 150 to 200 A

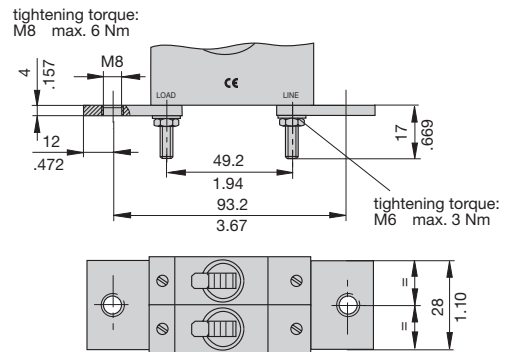

Internal connection diagrams

1-pole protected magnetically

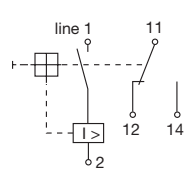

multipole

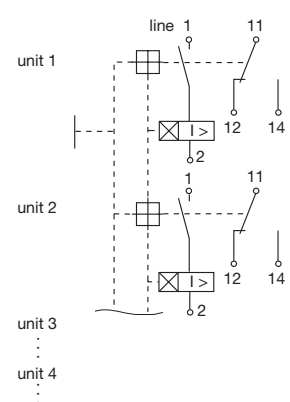

1-pole protected hydraulic-magnetically

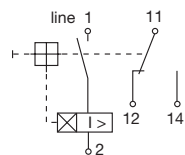

Typical time/current characteristics at +23 °C / +73.4 °F

(trip time at rated current and all poles symmetrically loaded)

Curve K1 (short delay) for DC

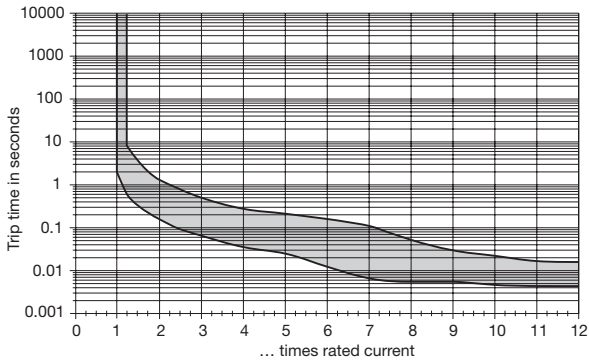

Curve M0 (medium delay) for AC/DC

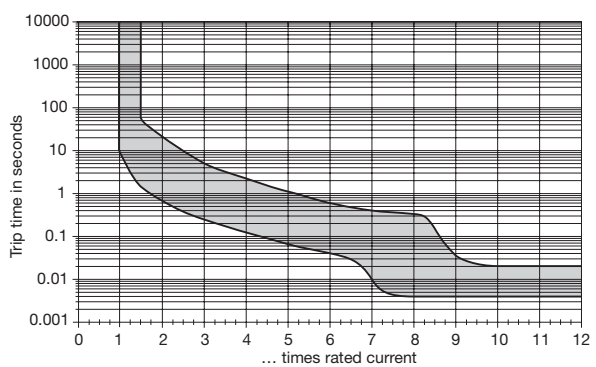

Curve K2 (short delay) for AC 50/60 Hz

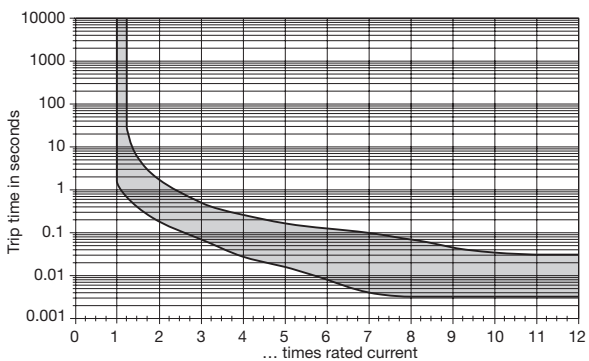

Curve M1 (medium delay) for DC

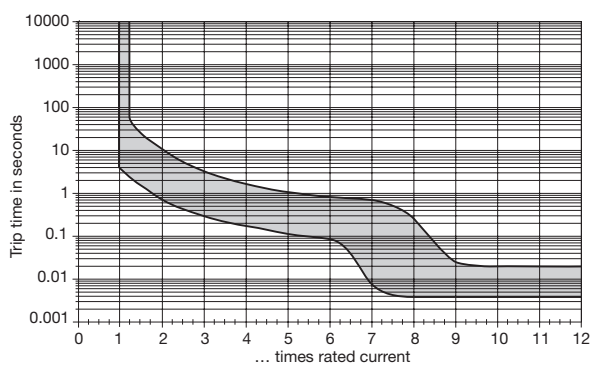

Curve T1 (long delay) for DC

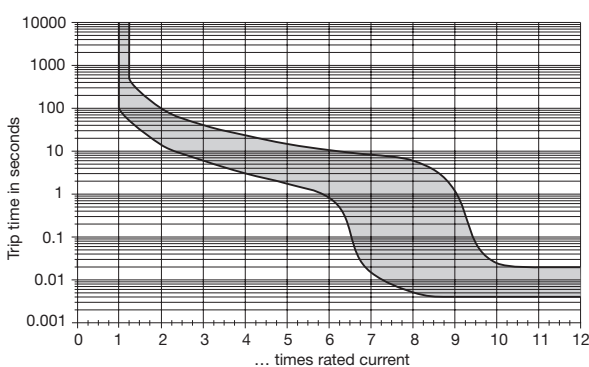

Curve M2 (medium delay) for AC 50/60 Hz

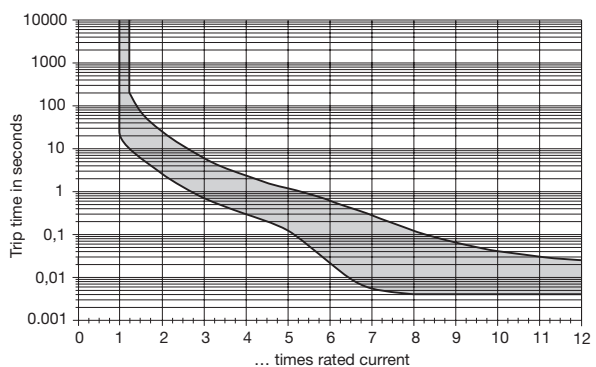

Curve T2 (long delay) for AC 50/60 Hz

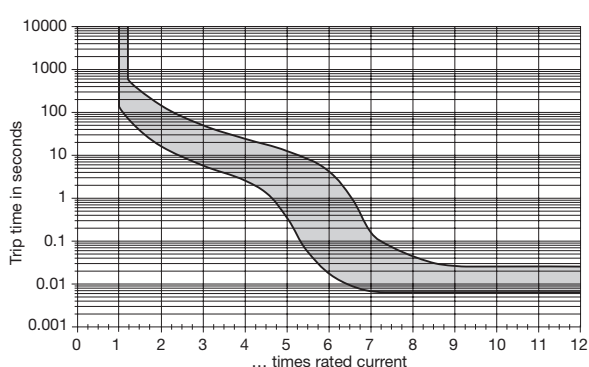

All curves will only be maintained if the escutcheon is mounted on a vertical surface.

Other characteristic curves to special order (e. g. pulse delayed, for high inrush currents or capacitive loads).

Interphase barriers / Dimensions

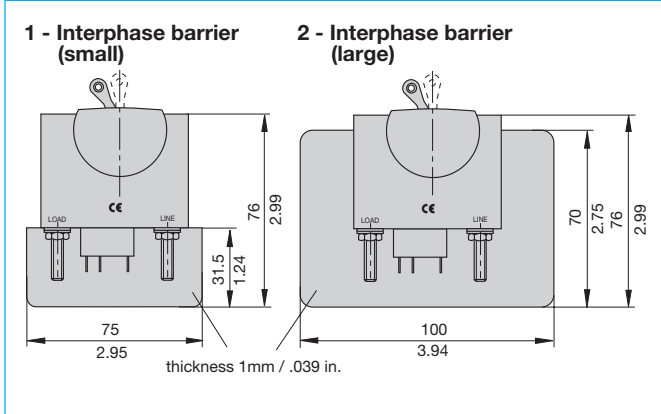

Shock directions

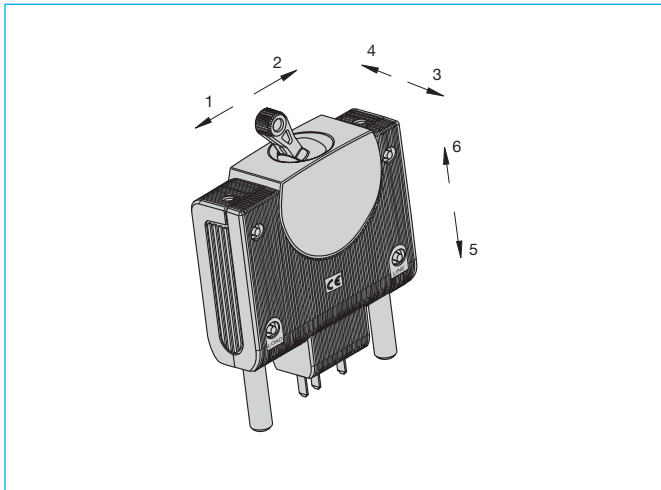

Accessories

Splash cover (IP65) for 1-, 2-, 3-pole (only for mounting version B/C)

	number of poles	mounting version	actuator configuration
X 222 444 01	1-pole	B	1
X 222 444 02	1-pole	C	1
X 222 444 11	2-pole	B	2
X 222 444 12	2-pole	C	2
X 222 444 21	3-pole	B	3
X 222 444 22	3-pole	C	3

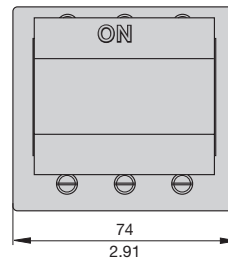
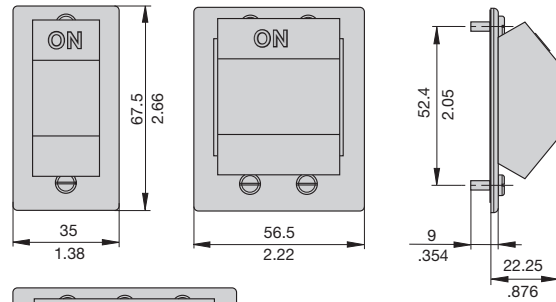

Toggle guard (only for mounting version B/C)
Y 307 381 01

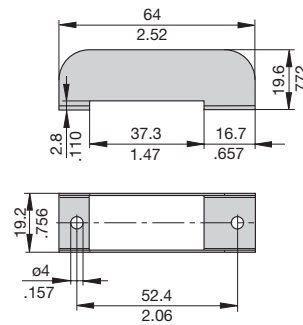

This is a metric design and millimeter dimensions take precedence (mm/inch)

All dimensions without tolerances are for reference only. In the interest of improved design, performance and cost effectiveness the right to make changes in these specifications without notice is reserved. Product markings may not be exactly as the ordering codes. Errors and omissions excepted.



Remote trip module X8345-F for Circuit Breaker 8345-...

Description

A module which adds remote trip capability to all versions of type 8345. A voltage applied across the coil, by means of an external sensor for example, will cause disconnection of the main switch/circuit breaker mechanism.

Typical applications

Electrical monitoring of safety systems, remote trip.

Ordering information

Type No.	
X8345	Module for type 8345
Module	
F	remote trip module
Assembly version	
01	only in pole 1
02	only in pole 2
03	only in pole 3
04	only in pole 4
Remote trip version	
X1	DC
Voltage rating	
12	12 V
24	24 V
Terminal design	
02	blade terminals DIN 4644-A2.8-0.5
M	module mounted to circuit breaker
X8345 - F 01 X1 12 02 M	ordering example

Voltage ratings and typical internal resistance values

Voltage ratings	Internal resistance (Ω)
DC 12 V	3.4
DC 24 V	13.9

This is a metric design and millimeter dimensions take precedence ($\frac{\text{mm}}{\text{inch}}$)

All dimensions without tolerances are for reference only. In the interest of improved design, performance and cost effectiveness the right to make changes in these specifications without notice is reserved. Product markings may not be exactly as the ordering codes. Errors and omissions excepted.

Dimensions

Additional remote trip module

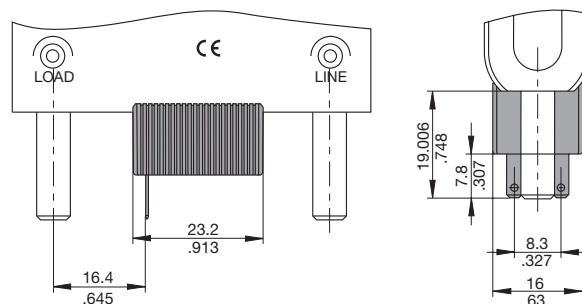

Internal connection diagram

1-pole protected hydraulic-magnetically with additional remote trip coil

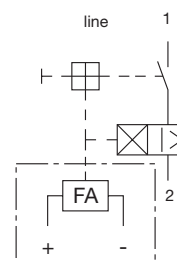

Technical data

Voltage ratings	DC 12 V and DC 24 V
Power consumption	approx. 40 W
Pulse operation	20 ms < t _{ON} < 100 ms / t _{OFF} > 10 sec (Continuous duty possible for multipole devices upon request)
Typical life	10,000 operations at U _N
Ambient temperature	-40...+85 °C (-40...+185 °F)
Insulation co-ordination (IEC 60664)	2.5 kV/2 (EN 60934)
Dielectric strength between main circuit and trip coil circuit	test voltage AC 3,000 V (EN 60934)
Insulation resistance	> 100 MΩ (DC 500 V)
Vibration	6 g (57-2000 Hz) ±0.46 mm (10-57 Hz) shock direction 1/2 4 g (57-2000 Hz) ±0.30 mm (10-57 Hz) shock direction 3/4 3 g (57-2000 Hz) ±0.23 mm (10-57 Hz) shock direction 5/6 to IEC 60068-2-6, test Fc 10 frequency cycles/axis
Shock	100 g (11 ms) (not when mounted upside down) to IEC 60068-2-27, test Ea
Corrosion	96 hours at 5 % salt mist, to IEC 60068-2-11, test Ka
Humidity	240 hours at 95 % RH to IEC 60068-2-3, test Ca
Mass	approx. 8.5 g (without base unit)