

Excellent Integrated System Limited

Stocking Distributor

Click to view price, real time Inventory, Delivery & Lifecycle Information:

[E-Switch](#)
[100SP1K1B25M1REH](#)

For any questions, you can email us directly:

sales@integrated-circuit.com

SHEET 1 OF 1

SWITCH FUNCTION		
POS. 1	POS. 2	POS. 3
ON	NONE	ON
2-3	OPEN	2-1

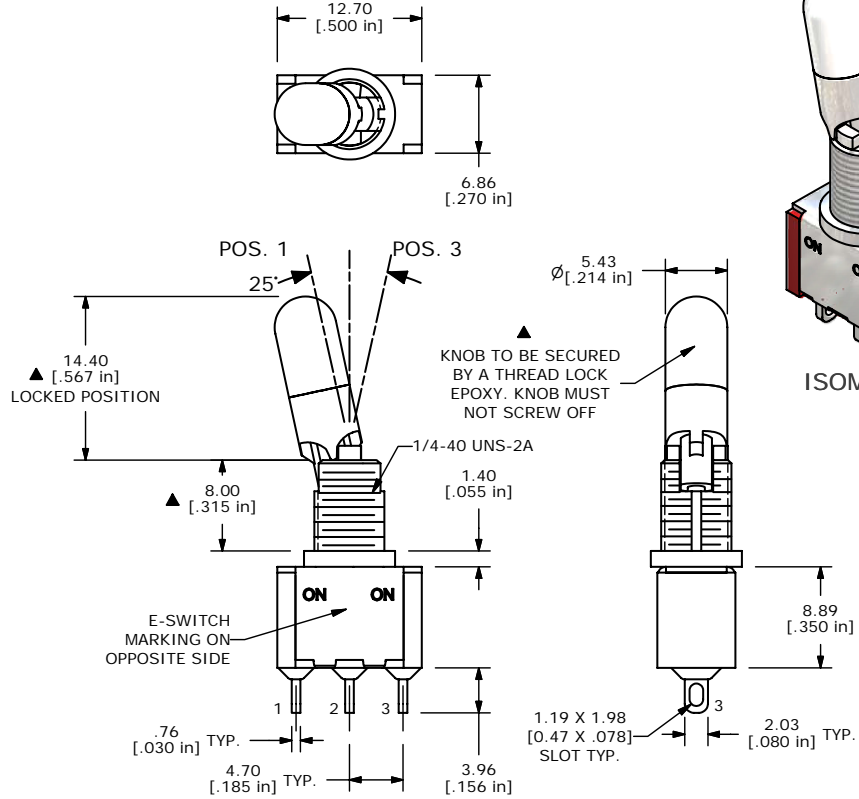
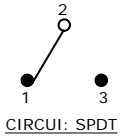

- NOTE:
1. ALL DIMENSIONS IN MM [INCH]
 2. GENERAL TOLERANCE: X.X=±0.4 X.XX=±0.25
 3. TERMINAL NUMBERS FOR REF ONLY
 - ▲4. PLATING MATERIAL: GOLD
 5. RATING: 0.4VA MAX @ 20V MAX (AC or DC)
 6. ELECTRIC LIFE: 40,000 make-and-break cycles at full load.
 7. INSULATION RESISTANCE: 1,000 Mega-ohm min.
 8. DIELECTRIC STRENGTH: 1,000 V RMS @sea level.
 9. OPERATING TEMP.: -30°C to 85°C
 10. ▲ DENOTES CRITICAL PARAMETER.
 11. 2002/95/EC (ROHS) COMPLIANT
 - ▲12. PACKAGE: TRAY/ 108 PIECES PER
 - ▲13. HARDWARE TO BE SUPPLIED BULK:
 T100011-LOCK WASHER QTY-1
 T100015-LOCK RING QTY-1
 T100000-HEX NUT QTY-2



TITLE 100SP1K1B25M1REH

A	17132	RELEASED FOR PRODUCTION	3/22/07	TN
REV	PCR NO	DESCRIPTION	DATE	BY

THE INFORMATION CONTAINED IN THIS DOCUMENT IS PROPRIETARY TO E-SWITCH AND IS NOT TO BE COPIED OR TRANSFERRED

SCALE 2:1	DATE 3/22/2007	DR TN	DWG ST116012	REV A
-----------	----------------	-------	--------------	-------