

Excellent Integrated System Limited

Stocking Distributor

Click to view price, real time Inventory, Delivery & Lifecycle Information:

[E-Switch](#)
[TD1146](#)

For any questions, you can email us directly:

sales@integrated-circuit.com

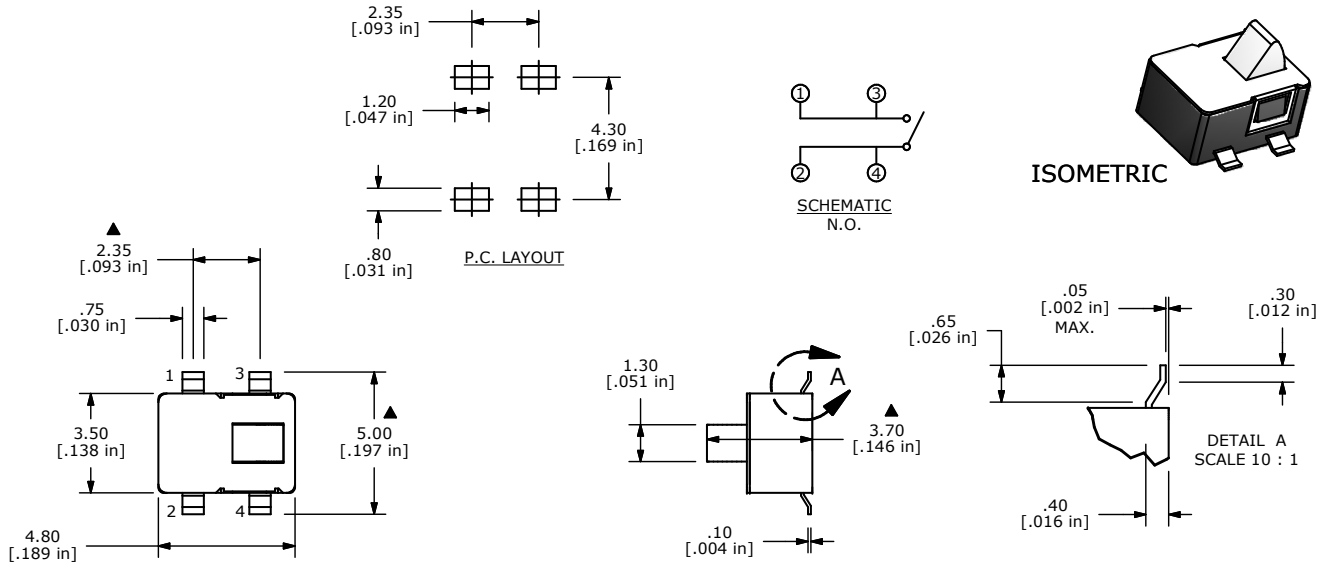

- NOTES:
1. ALL DIMENSIONS IN MM
 2. GENERAL TOLERANCE: X.X=±0.4
X.XX=±0.25
 3. TERM. NOS. FOR REFERENCE ONLY.
 - ▲ 4. RATING: 1mA @ 5VDC
 - ▲ 5. OPERATING POSITION = 2.90 ± 0.30
 - ▲ 6. OPERATING FORCE: ≤ 50 gf
 7. CONTACT RESISTANCE: 100 MILLI OHMS MAX. (INITIAL)
 8. MECHANICAL / ELECTRICAL LIFE: 30,000 min.
 9. INSULATION RESISTANCE: 100 MEGA OHMS min.
 10. OPERATING TEMPERATURE: -25° C TO 70° C
 11. DIELECTRIC STRENGTH: 100 VAC FOR 1 MINUTE.
 12. PACKAGE: POLYBAG/250 PIECES PER
 13. ▲ DENOTES CRITICAL PARAMETER
 14. 2002/95/EC (ROHS) COMPLIANT

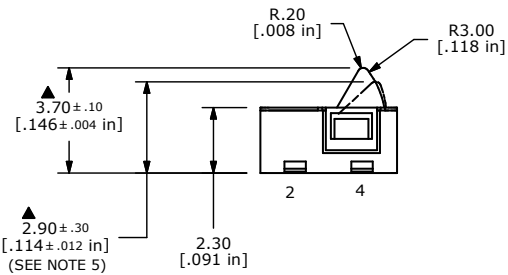

TITLE TD1146

A	18242	RELEASE FOR PRODUCTION	9/11/08	BLR
REV	PCR NO	DESCRIPTION	DATE	BY

THE INFORMATION CONTAINED IN THIS DOCUMENT IS PROPRIETARY TO E-SWITCH AND IS NOT TO BE COPIED OR TRANSFERRED

SCALE 5:1	DATE 9/11/2008	DR BLR	DWG Q940000	REV A
-----------	----------------	--------	-------------	-------