

Excellent Integrated System Limited

Stocking Distributor

Click to view price, real time Inventory, Delivery & Lifecycle Information:

[E-Switch](#)
[TL6190AF220R](#)

For any questions, you can email us directly:

sales@integrated-circuit.com

SHEET 1 OF 1

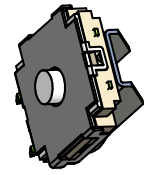
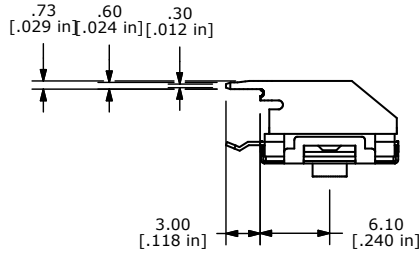
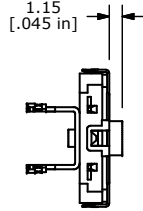
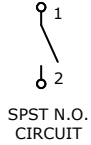
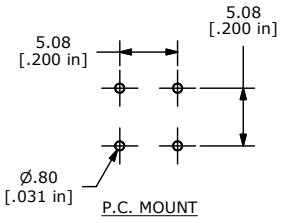

ISOMETRIC

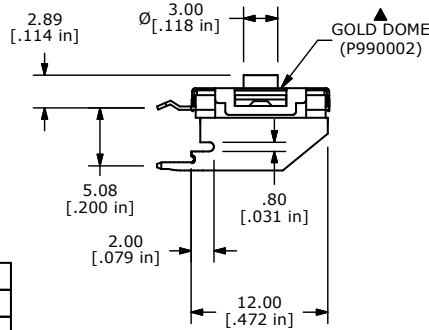
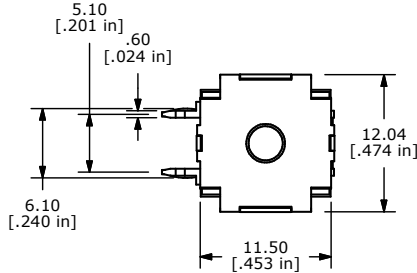

- NOTES:
 1. ALL DIMENSIONS IN MM [IN].
 2. GENERAL TOLERANCE: X.X=±0.4
 X.XX=±0.25
 3. TERM. NOS. FOR REFERENCE ONLY.
 4. RATING: 12V, 50mA MAX; 100mV, 10mA MIN
 ▲5. OPERATING FORCE: 220±60 GRAMS
 6. TRAVEL: 0.50±0.20mm
 7. CONTACT RESISTANCE: 100 MILLI-OHMS MAX (INITIAL)
 8. MECHANICAL/ELECTRICAL LIFE: 100,000 CYCLES MIN
 ▲9. CONTACTS: GOLD, 10 MICRO INCHES MIN
 10. ▲ DENOTES CRITICAL PARAMETER.
 ▲11. SWITCH TO BE SEALED PER E-SWITCH BUBBLE TEST.
 12. OPERATING TEMPERATURE: -40C TO +105C
 13. PACKAGING: 41 PIECES PER TUBE
 14. 2002/95/EC (ROHS) COMPLIANT.

G	17671	CHANGED NOTE# 13 & DIM. 5.11 TO 5.08	9/13/07	BF
F	17372	UPDATE DRAWING	6/11/07	TN
E	17179	FIXED MODEL, DIMENSIONS	4/11/07	TN
D	17173	ADDED GOLD DOME NOTE	4/9/07	TN
C	16659	UPDATED PACKAGING "42", NOTES	11/15/2006	TN
B	16146	ADD PACKAGING NOTE	6/14/06	BK
A	16074	RELEASED TO PRODUCTION	5/31/06	BK
REV	PCR NO	DESCRIPTION	DATE	BY

THE INFORMATION CONTAINED IN THIS DOCUMENT IS PROPRIETARY TO E-SWITCH AND IS NOT TO BE COPIED OR TRANSFERRED



TITLE TL6190AF220R

SCALE	DATE	DR	DWG	REV
2:1	9/13/2007	BF	P600000	G