

Excellent Integrated System Limited

Stocking Distributor

Click to view price, real time Inventory, Delivery & Lifecycle Information:

[Knowles](#)

[ED-23145-000](#)

For any questions, you can email us directly:

sales@integrated-circuit.com

ED-23145-000

SHT 1.1

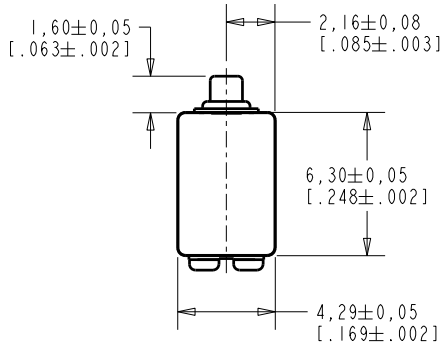

NOTE:

- 1 A POSITIVE GOING VOLTAGE AT TERMINAL 2, RELATIVE TO TERMINAL 1, CAUSES A DECREASE IN PRESSURE AT THE SOUND OUTLET.
- 2 LOCATED FROM TWO SURFACES FOR CUSTOMER CONVENIENCE. ONLY APPLICABLE FROM ONE SURFACE, NOT TO BE USED TOGETHER. HORIZONTAL LOCATION FOR TERMINAL CENTERED TO ±0,17 [.007].

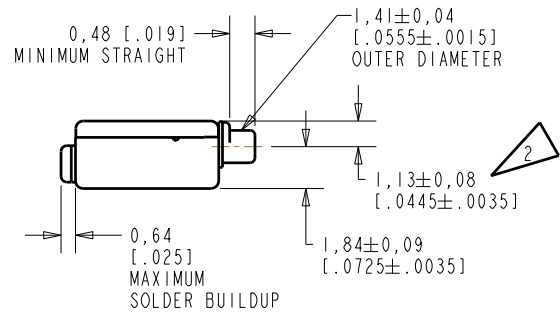
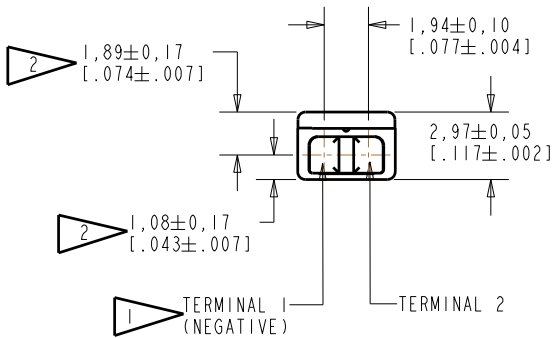

NOMINAL WEIGHT
.31 GRAM

DIMENSIONS IN MILLIMETERS [INCHES]

Revision	C.O. #	Implementation Date	RELEASE LEVEL	REVISION
B	C10107990	8-20-08	Active	B
A	C10104534	7-14-06		

KNOWLES ELECTRONICS
ITASCA, ILLINOIS U.S.A.

SCALE:	4:1		DR. BY	DATE
DO NOT SCALE DRAWING				
TITLE:	RECEIVER	ED-23145-000	CK. BY	DATE
	OUTLINE DRAWING	SHT 1.1	GJP	7-18-06
			APP. BY	DATE
			GJP	7-18-06

KE111ASIZE.FRM

Rev: B

NO DAMPING

ED-23145-000

SHEET 2.1

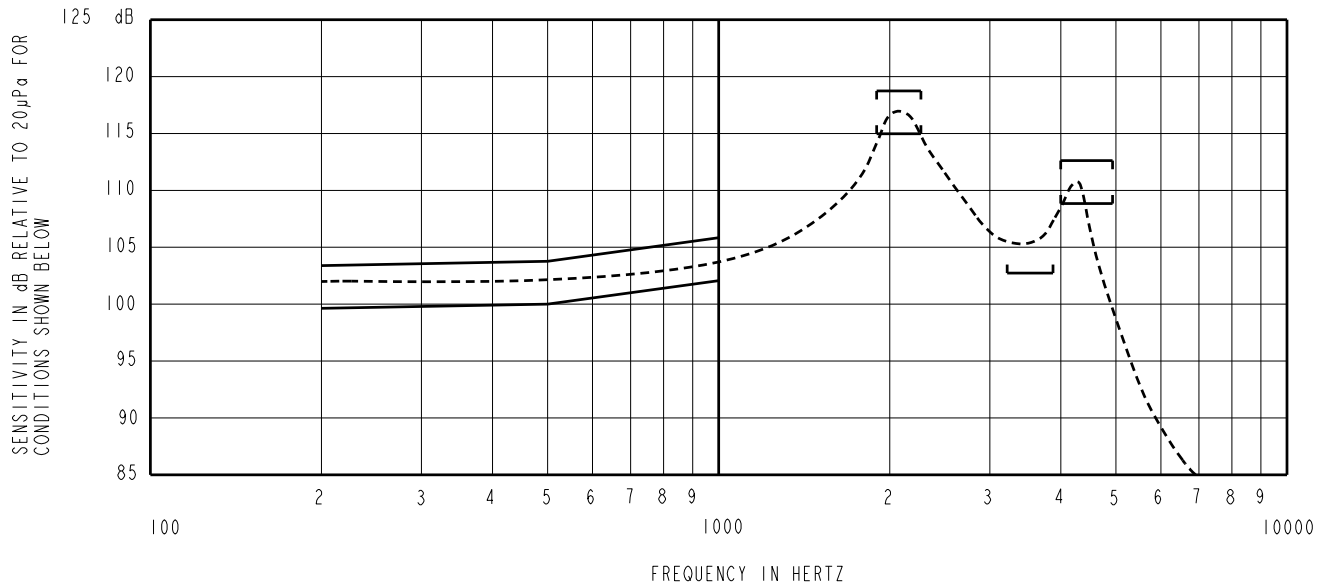

NOTES:

1. MEASUREMENTS MADE USING 10mm (.394") X 1mm (.039") ID TUBE CONNECTED TO A SIMULATED ANSI S3.7-1973 TYPE HA-3 COUPLER. (IEC 126).

2.

SENSITIVITY

<u>FREQUENCY</u>	<u>MIN.</u>	<u>MAX.</u>
200	99.5	103.5
500	100.0	104.0
1000	102.0	106.0
1900-2300	115.0	119.0
3200-3900	102.5	- - -
4000-5000	109.0	113.0

3. RESPONSE, IMPEDANCE, AND DISTORTION MEASUREMENTS MADE USING THE ELECTRICAL TEST CONDITIONS SHOWN BELOW.

4. ELECTRICAL SOURCE IMPEDANCE MUST BE GREATER THAN 20 TIMES 1KHz IMPEDANCE FOR TEST CONDITIONS SHOWN BELOW.

5. INDIVIDUAL SPECIFICATIONS.

PORT LOCATION	IMPEDANCE OHMS ±15%		DCR @20°C OHMS ±10%	DISTORTION		ELECTRICAL TEST CONDITIONS	
	1KHz	500Hz		MAX. %	FREQ Hz	AC mA RMS	DC mA
12C	1450	780	376	5	800	0.50	0.00