

## Excellent Integrated System Limited

Stocking Distributor

Click to view price, real time Inventory, Delivery & Lifecycle Information:

[Vishay Semiconductor/Opto Division](#)  
[K824P](#)

For any questions, you can email us directly:

[sales@integrated-circuit.com](mailto:sales@integrated-circuit.com)



# K814P, K824P, K844P

Vishay Semiconductors

## Optocoupler, Phototransistor Output, AC Input

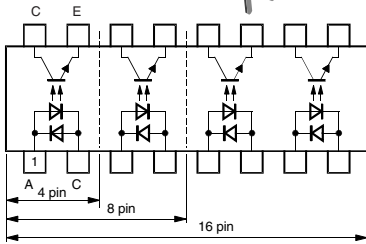
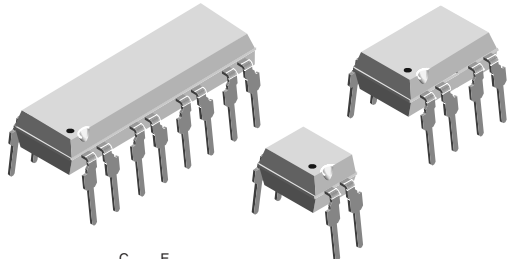

17220\_2



### DESCRIPTION

The K814P, K824P, K844P consist of a phototransistor optically coupled to 2 gallium arsenide infrared emitting diodes (reverse polarity) in 4 pin (single); 8 pin (dual) or 16-pin (quad) plastic dual inline package. The elements are mounted on one leadframe providing a fixed distance between input and output for highest safety requirements.

### FEATURES

- Endstackable to 2.54 mm (0.1") spacing
- DC isolation test voltage  $V_{ISO} = 5000 V_{RMS}$
- Low coupling capacitance of typical 0.3 pF
- Current transfer ratio (CTR) of typical 100 %
- Low temperature coefficient of CTR
- Wide ambient temperature range
- Lead (Pb)-free component
- Component in accordance to RoHS 2002/95/EC and WEEE 2002/96/EC



**RoHS**  
COMPLIANT

### APPLICATIONS

- Feature phones
- Answering machines
- PBX
- Fax machines

### AGENCY APPROVALS

- UL1577, file no. E76222 system code U, double protection
- C-UL CSA 22.2, bulletin 5A

### ORDER INFORMATION

PART	REMARKS
K814P	CTR > 20 %, single channel, DIP-4
K824P	CTR > 20 %, dual channel, DIP-8
K844P	CTR > 20 %, quad channel, DIP-16

### ABSOLUTE MAXIMUM RATINGS (1)

PARAMETER	TEST CONDITION	SYMBOL	VALUE	UNIT
<b>INPUT</b>				
Forward current		$I_F$	± 60	mA
Forward surge current	$t_p \leq 10 \mu s$	$I_{FSM}$	± 1.5	A
Power dissipation		$P_{diss}$	100	mW
Junction temperature		$T_j$	125	°C
<b>OUTPUT</b>				
Collector emitter voltage		$V_{CEO}$	70	V
Emitter collector voltage		$V_{ECO}$	7	V
Collector current		$I_C$	50	mA
Collector peak current	$t_p/T = 0.5, t_p \leq 10 ms$	$I_{CM}$	100	mA
Power dissipation		$P_{diss}$	150	mW
Junction temperature		$T_j$	125	°C

# K814P, K824P, K844P

Vishay Semiconductors Optocoupler, Phototransistor  
 Output, AC Input



ABSOLUTE MAXIMUM RATINGS <sup>(1)</sup>				
PARAMETER	TEST CONDITION	SYMBOL	VALUE	UNIT
<b>COUPLER</b>				
AC isolation test voltage (RMS)	t = 1.0 min	V <sub>ISO</sub>	5000	V <sub>RMS</sub>
Total power dissipation		P <sub>tot</sub>	250	mW
Operating ambient temperature range		T <sub>amb</sub>	- 40 to +100	°C
Storage temperature range		T <sub>stg</sub>	- 55 to + 125	°C
Soldering temperature <sup>(3)</sup>	2 mm from case, t ≤ 10 s	T <sub>sld</sub>	260	°C

## Notes

(1) T<sub>amb</sub> = 25 °C, unless otherwise specified.

Stresses in excess of the absolute maximum ratings can cause permanent damage to the device. Functional operation of the device is not implied at these or any other conditions in excess of those given in the operational sections of this document. Exposure to absolute maximum ratings for extended periods of the time can adversely affect reliability.

(2) Refer to wave profile for soldering conditions for through hole devices.

ELECTRICAL CHARACTERISTICS						
PARAMETER	TEST CONDITION	SYMBOL	MIN.	TYP.	MAX.	UNIT
<b>INPUT</b>						
Forward voltage	I <sub>F</sub> = ± 50 mA	V <sub>F</sub>		1.25	1.6	V
Reverse current	V <sub>R</sub> = ± 6 V	I <sub>R</sub>			10	μA
<b>OUTPUT</b>						
Collector emitter voltage	I <sub>C</sub> = 100 μA	V <sub>CEO</sub>	70			V
Emitter collector voltage	I <sub>E</sub> = 100 μA	V <sub>ECO</sub>	7			V
Collector dark current	V <sub>CE</sub> = 20 V, I <sub>F</sub> = 0, E = 0	I <sub>CEO</sub>			100	nA
<b>COUPLER</b>						
Collector emitter saturation voltage	I <sub>F</sub> = ± 10 mA, I <sub>C</sub> = 1 mA	V <sub>CEsat</sub>			0.3	V
Cut-off frequency	I <sub>F</sub> = ± 10 mA, V <sub>CE</sub> = 5 V, R <sub>L</sub> = 100 Ω	f <sub>c</sub>		100		kHz
Coupling capacitance	f = 1 MHz	C <sub>k</sub>		0.3		pF

## Note

T<sub>amb</sub> = 25 °C, unless otherwise specified.

Minimum and maximum values are testing requirements. Typical values are characteristics of the device and are the result of engineering evaluation. Typical values are for information only and are not part of the testing requirements.

CURRENT TRANSFER RATIO							
PARAMETER	TEST CONDITION	PART	SYMBOL	MIN.	TYP.	MAX.	UNIT
I <sub>C</sub> /I <sub>F</sub>	V <sub>CE</sub> = 5 V, I <sub>F</sub> = ± 5 mA	K814P	CTR	20		300	%

SWITCHING CHARACTERISTICS						
PARAMETER	TEST CONDITION	SYMBOL	MIN.	TYP.	MAX.	UNIT
Delay time	V <sub>S</sub> = 5 V, I <sub>C</sub> = 2 mA, R <sub>L</sub> = 100 Ω (see figure 1)	t <sub>d</sub>		3		μs
Rise time	V <sub>S</sub> = 5 V, I <sub>C</sub> = 2 mA, R <sub>L</sub> = 100 Ω (see figure 1)	t <sub>r</sub>		3		μs
Fall time	V <sub>S</sub> = 5 V, I <sub>C</sub> = 2 mA, R <sub>L</sub> = 100 Ω (see figure 1)	t <sub>f</sub>		4.7		μs
Storage time	V <sub>S</sub> = 5 V, I <sub>C</sub> = 2 mA, R <sub>L</sub> = 100 Ω (see figure 1)	t <sub>s</sub>		0.3		μs
Turn-on time	V <sub>S</sub> = 5 V, I <sub>C</sub> = 2 mA, R <sub>L</sub> = 100 Ω (see figure 1)	t <sub>on</sub>		6		μs
Turn-off time	V <sub>S</sub> = 5 V, I <sub>C</sub> = 2 mA, R <sub>L</sub> = 100 Ω (see figure 1)	t <sub>off</sub>		5		μs
Turn-on time	V <sub>S</sub> = 5 V, I <sub>C</sub> = 10 mA, R <sub>L</sub> = 1 kΩ (see figure 1)	t <sub>on</sub>		9		μs
Turn-off time	V <sub>S</sub> = 5 V, I <sub>C</sub> = 10 mA, R <sub>L</sub> = 1 kΩ (see figure 1)	t <sub>off</sub>		18		μs



**K814P, K824P, K844P**

Optocoupler, Phototransistor Output, AC Input Vishay Semiconductors

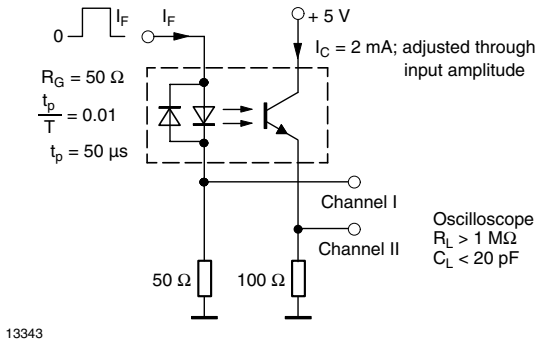

Fig. 1 - Test Circuit, Non-Saturated Operation

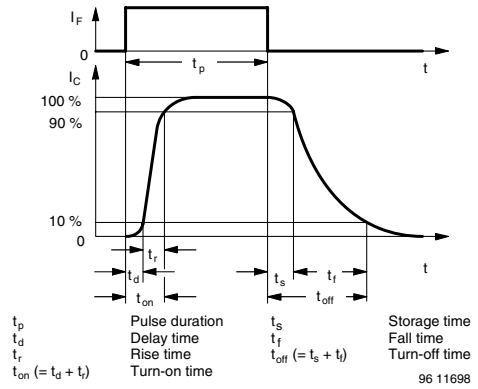

Fig. 3 - Switching Times

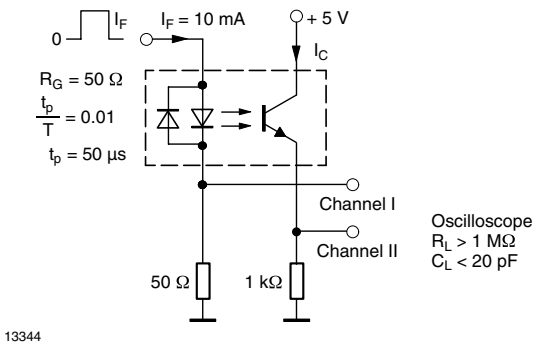

Fig. 2 - Test Circuit, Saturated Operation

**TYPICAL CHARACTERISTICS**

T<sub>amb</sub> = 25 °C, unless otherwise specified

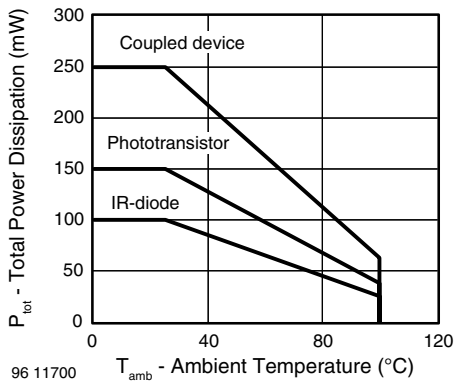

Fig. 4 - Total Power Dissipation vs. Ambient Temperature

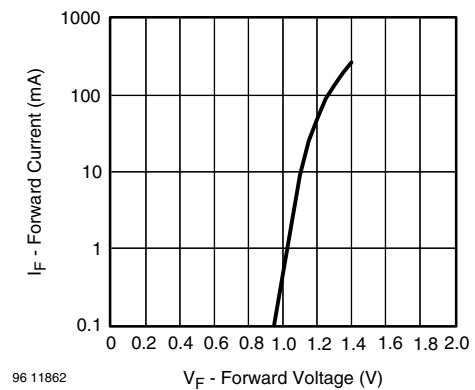

Fig. 5 - Forward Current vs. Forward Voltage

**K814P, K824P, K844P**



Vishay Semiconductors Optocoupler, Phototransistor  
Output, AC Input

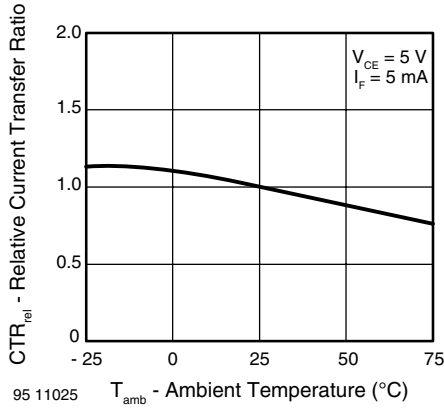

Fig. 6 - Relative Current Transfer Ratio vs. Ambient Temperature

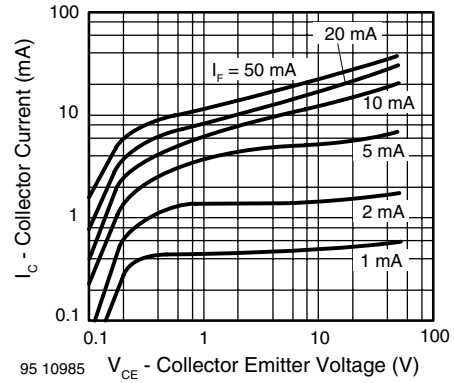

Fig. 9 - Collector Current vs. Collector Emitter Voltage

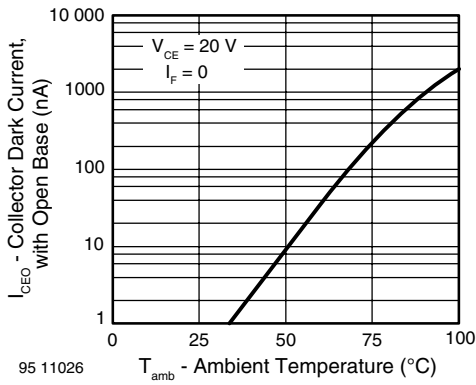

Fig. 7 - Collector Dark Current vs. Ambient Temperature

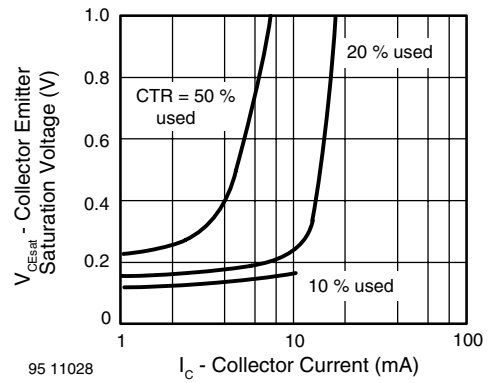

Fig. 10 - Collector Emitter Saturation Voltage vs. Collector Current

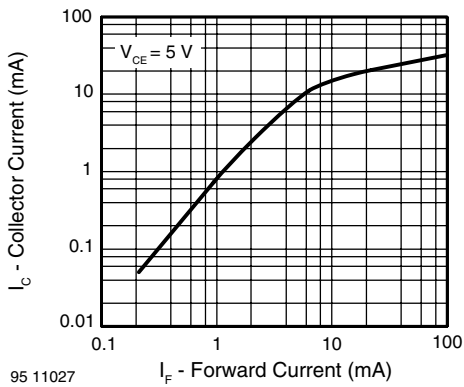

Fig. 8 - Collector Current vs. Forward Current

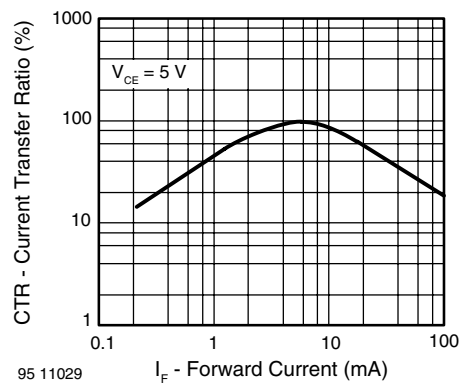

Fig. 11 - Current Transfer Ratio vs. Forward Current



**K814P, K824P, K844P**

Optocoupler, Phototransistor Output, AC Input Vishay Semiconductors

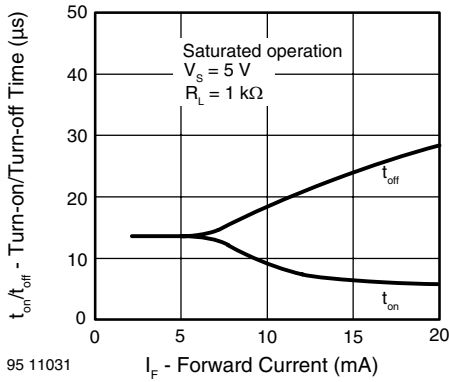

Fig. 12 - Turn-on/turn-off Time vs. Forward Current

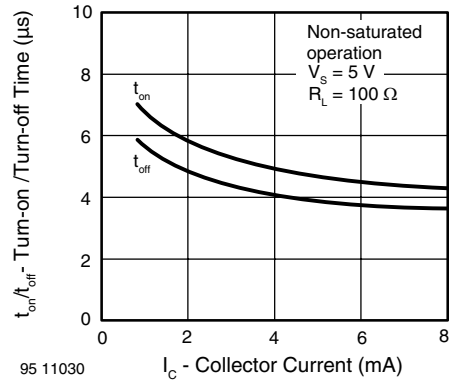
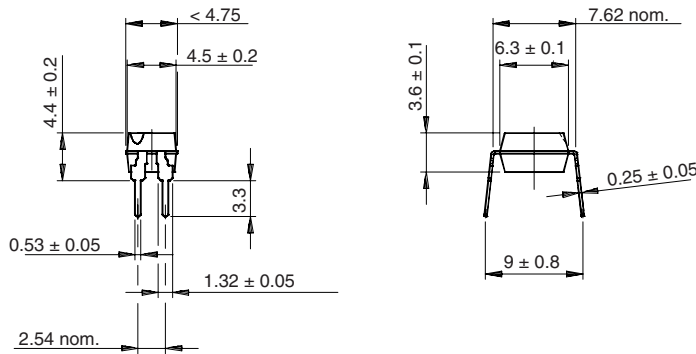

Fig. 13 - Turn-on/turn-off Time vs. Collector Current

**PACKAGE DIMENSIONS** in millimeters



E. g.:  
Special features: endstackable  
to 2.54 mm (0.100") spacing

Weight: ca. 0.25 g  
Creepage distance: > 6 mm  
Air path: > 6 mm  
after mounting on PC board

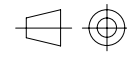
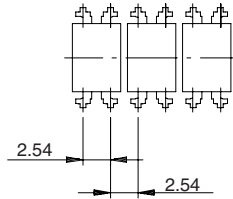
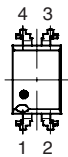

technical drawings  
according to DIN  
specifications

14789

Drawing-No.: 6.544-5302.03-4  
Issue: 5; 20.03.02

**K814P, K824P, K844P**

Vishay Semiconductors Optocoupler, Phototransistor  
Output, AC Input

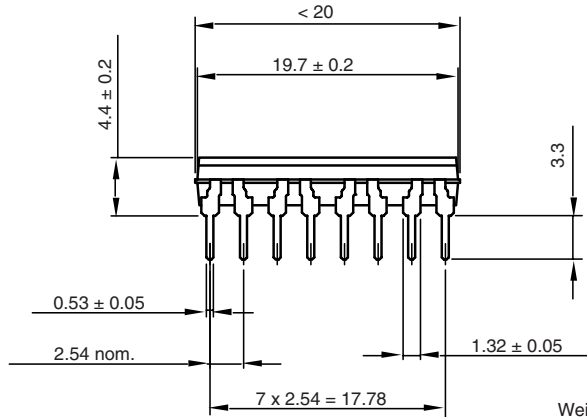

Weight: ca. 1.08 g  
 Creepage distance: > 6 mm  
 Air path: > 6 mm  
 after mounting on PC board

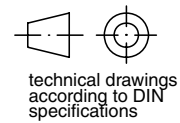

technical drawings according to DIN specifications

Drawing-No.: 6.544-5302.01-4

Issue: 4; 02.06.99

14783

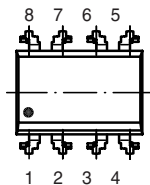
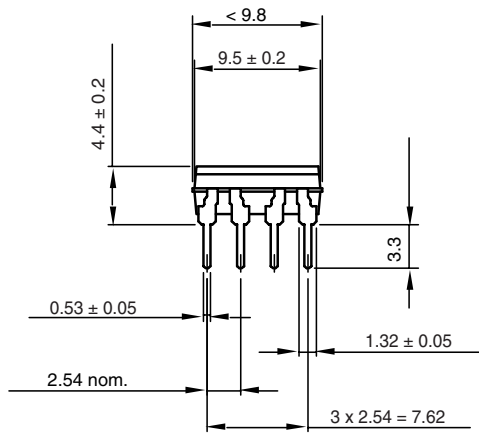

Weight: ca. 0.55 g  
 Creepage distance: > 6 mm  
 Air path: > 6 mm  
 after mounting on PC board

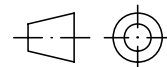

technical drawings according to DIN specifications

Drawing-No.: 6.544-5302.02-4

Issue: 4; 02.06.99

14784

**K814P, K824P, K844P**Optocoupler, Phototransistor  
Output, AC Input

Vishay Semiconductors

**OZONE DEPLETING SUBSTANCES POLICY STATEMENT**

It is the policy of Vishay Semiconductor GmbH to

1. Meet all present and future national and international statutory requirements.
2. Regularly and continuously improve the performance of our products, processes, distribution and operating systems with respect to their impact on the health and safety of our employees and the public, as well as their impact on the environment.

It is particular concern to control or eliminate releases of those substances into the atmosphere which are known as ozone depleting substances (ODSs).

The Montreal Protocol (1987) and its London Amendments (1990) intend to severely restrict the use of ODSs and forbid their use within the next ten years. Various national and international initiatives are pressing for an earlier ban on these substances.

Vishay Semiconductor GmbH has been able to use its policy of continuous improvements to eliminate the use of ODSs listed in the following documents.

1. Annex A, B and list of transitional substances of the Montreal Protocol and the London Amendments respectively.
2. Class I and II ozone depleting substances in the Clean Air Act Amendments of 1990 by the Environmental Protection Agency (EPA) in the USA.
3. Council Decision 88/540/EEC and 91/690/EEC Annex A, B and C (transitional substances) respectively.

Vishay Semiconductor GmbH can certify that our semiconductors are not manufactured with ozone depleting substances and do not contain such substances.

We reserve the right to make changes to improve technical design  
and may do so without further notice.

Parameters can vary in different applications. All operating parameters must be validated for each customer application by the customer. Should the buyer use Vishay Semiconductors products for any unintended or unauthorized application, the buyer shall indemnify Vishay Semiconductors against all claims, costs, damages, and expenses, arising out of, directly or indirectly, any claim of personal damage, injury or death associated with such unintended or unauthorized use.

Vishay Semiconductor GmbH, P.O.B. 3535, D-74025 Heilbronn, Germany





### Disclaimer

ALL PRODUCT, PRODUCT SPECIFICATIONS AND DATA ARE SUBJECT TO CHANGE WITHOUT NOTICE TO IMPROVE RELIABILITY, FUNCTION OR DESIGN OR OTHERWISE.

Vishay Intertechnology, Inc., its affiliates, agents, and employees, and all persons acting on its or their behalf (collectively, "Vishay"), disclaim any and all liability for any errors, inaccuracies or incompleteness contained in any datasheet or in any other disclosure relating to any product.

Vishay makes no warranty, representation or guarantee regarding the suitability of the products for any particular purpose or the continuing production of any product. To the maximum extent permitted by applicable law, Vishay disclaims (i) any and all liability arising out of the application or use of any product, (ii) any and all liability, including without limitation special, consequential or incidental damages, and (iii) any and all implied warranties, including warranties of fitness for particular purpose, non-infringement and merchantability.

Statements regarding the suitability of products for certain types of applications are based on Vishay's knowledge of typical requirements that are often placed on Vishay products in generic applications. Such statements are not binding statements about the suitability of products for a particular application. It is the customer's responsibility to validate that a particular product with the properties described in the product specification is suitable for use in a particular application. Parameters provided in datasheets and / or specifications may vary in different applications and performance may vary over time. All operating parameters, including typical parameters, must be validated for each customer application by the customer's technical experts. Product specifications do not expand or otherwise modify Vishay's terms and conditions of purchase, including but not limited to the warranty expressed therein.

Except as expressly indicated in writing, Vishay products are not designed for use in medical, life-saving, or life-sustaining applications or for any other application in which the failure of the Vishay product could result in personal injury or death. Customers using or selling Vishay products not expressly indicated for use in such applications do so at their own risk. Please contact authorized Vishay personnel to obtain written terms and conditions regarding products designed for such applications.

No license, express or implied, by estoppel or otherwise, to any intellectual property rights is granted by this document or by any conduct of Vishay. Product names and markings noted herein may be trademarks of their respective owners.