

Excellent Integrated System Limited

Stocking Distributor

Click to view price, real time Inventory, Delivery & Lifecycle Information:

[NVE Corporation](#)
[IL485W](#)

For any questions, you can email us directly:

sales@integrated-circuit.com

Isolated RS485 Interface With Handshake

Functional Diagram

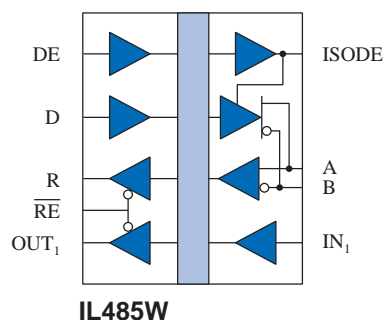

| V _{ID} (A-B) | DE | RE | ISODE | R | D | Mode |
|--------------------------|----|----|-------|---|---|---------------|
| ≥ 200 mV | L | L | L | H | X | Receive |
| ≤ -200 mV | L | L | L | L | X | Receive |
| -7 < V _I < 12 | X | H | X | Z | X | Receive/Drive |
| ≥ 1.5 V | H | L | H | H | H | Drive |
| ≤ -1.5 V | H | L | H | L | L | Drive |
| Open | L | L | L | H | X | Indeterminate |

H = High Level, L = Low Level
X = Irrelevant, Z = High Impedance

| RE | IN1 | OUT1 |
|----|-----|------|
| L | L | L |
| L | H | H |
| H | X | Z |

Features

- 2500 V_{RMS} Isolation (1 min.)
- 25 ns Maximum Propagation Delay
- 35 Mbps Data Rate
- 1 ns Pulse Skew (typ.)
- Designed for Multi-point Transmission on Long Bus Lines in Noisy Environments
- ±60 mA Driver Output Capability
- Thermal Shutdown Protection
- Meets or Exceeds ANSI RS-485 and ISO 8482:1987(E)
- -40°C to +85°C Temperature Range
- PROFIBUS International Component Recognition
- 16-Pin SOIC Package
- UL1577 and IEC 61010-2001 Approval

Applications

- Profibus/RS485 Systems
- Multiple Data Point Transmission

Description

The IL485W is a galvanically isolated, high-speed differential bus transceiver, designed for bidirectional data communication on balanced transmission lines. The devices use NVE's patented* IsoLoop spintronic Giant Magnetoresistance (GMR) technology. The IL485W is the first isolated RS-485 interface in a standard 16-pin SOIC package that meets the ANSI Standards EIA/TIA-422-B and RS-485 and is compatible with 3.3V input supplies.

The IL485W has current limiting and thermal shutdown features to protect against output short circuits and bus contention situations that could cause excessive power dissipation.

With 1 ns pulse skew and 16 ns propagation delay, the IL485W is ideal for PROFIBUS applications.

DE/ISODE and IN1/OUT1 allow isolated RTSAS and DTSAS handshaking.

Absolute Maximum Ratings⁽¹⁾

| Parameters | Symbol | Min. | Typ. | Max. | Units | Test Conditions |
|------------------------------------|--------------------|------|------|--------------|-------|-----------------|
| Storage Temperature | T_S | -65 | | 150 | °C | |
| Ambient Operating Temperature | T_A | -40 | | 100 | °C | |
| Voltage Range at A or B Bus Pins | | -7 | | 12 | V | |
| Supply Voltage ⁽¹⁾ | V_{DD1}, V_{DD2} | -0.5 | | 7 | V | |
| Digital Input Voltage | | -0.5 | | 5.5 | V | |
| Digital Output Voltage | | -0.5 | | $V_{DD} + 1$ | V | |
| Continuous Total Power Dissipation | | | | 725 377 | mW | 25°C 85°C |
| Maximum Output Current | I_O | | | 95 | mA | |
| Lead Solder Temperature | | | | 260 | °C | 10 sec. |
| ESD | | | 2 | | kV | HBM |

Recommended Operating Conditions

| Parameters | Symbol | Min. | Typ. | Max. | Units | Test Conditions |
|---|--------------------|------|------|-----------|-------|-----------------|
| Supply Voltage | V_{DD1}, V_{DD2} | 4.5 | | 5.5 | V | |
| Input Voltage at any Bus Terminal (separately or common mode) | V_I V_{IC} | | | 12 -7 | V | |
| High-Level Digital Input Voltage | V_{IH} | 3.0 | | V_{DD1} | V | |
| Low-Level Digital Input Voltage | V_{IL} | 0 | | 0.8 | V | |
| Differential Input Voltage ⁽²⁾ | V_{ID} | | | +12/-7 | V | |
| High-Level Output Current (Driver) | I_{OH} | | | 60 | mA | |
| High-Level Digital Output Current (Receiver) | I_{OH} | | | 8 | mA | |
| Low-Level Output Current (Driver) | I_{OL} | -60 | | | mA | |
| Low-Level Digital Output Current (Receiver) | I_{OL} | -8 | | | mA | |
| Ambient Operating Temperature | T_A | -40 | | 85 | °C | |
| Transient Immunity | 20 | | | | kV/μs | |
| Digital Input Signal Rise and Fall Times | t_{IR}, t_{IF} | | | | | DC Stable |

Insulation Specifications

| Parameters | Symbol | Min. | Typ. | Max. | Units | Test Conditions |
|-------------------|--------|------|------------------------|------|-------|-----------------------|
| Creepage Distance | | 8.08 | | | | mm |
| Barrier Impedance | | | $>10^{14} \parallel 7$ | | | $\Omega \parallel$ pF |
| Leakage Current | | | 0.2 | | μA | 240 V_{RMS} , 60 Hz |

Safety and Approvals

IEC61010-1

TUV Certificate Numbers: **N1502812, N1502812-101**

Classification: Reinforced Insulation

| Model | Package | Pollution Degree | Material Group | Max. Working Voltage |
|--------|-----------|------------------|----------------|----------------------|
| IL485W | 0.3" SOIC | II | III | 300 V_{RMS} |

UL 1577

Component Recognition Program File Number: E207481
 Rated 2500 V_{RMS} for 1 minute

Soldering Profile

Per JEDEC J-STD-020C, MSL=2

IL485W Pin Connections

| | | |
|----|------------------|---|
| 1 | V _{DD1} | Input Power Supply |
| 2 | GND ₁ | Input Power Supply Ground Return |
| 3 | R | Output Data from Bus |
| 4 | OUT ₁ | Output from Auxiliary Isolation Channel |
| 5 | \overline{RE} | Read Data Enable (if \overline{RE} is high, R= high impedance) |
| 6 | DE | Drive Enable |
| 7 | D | Data Input to Bus |
| 8 | GND ₁ | Input Power Supply Ground Return |
| 9 | GND ₂ | Output Power Supply Ground Return |
| 10 | ISODE | Isolated DE Output for use in Profibus applications where the state of the isolated drive enable node needs to be monitored |
| 11 | IN ₁ | No Internal Connection |
| 12 | A | Non-inverting Bus Line |
| 13 | B | Inverting Bus Line |
| 14 | NC | No Internal Connection |
| 15 | GND ₂ | Output Power Supply Ground Return |
| 16 | V _{DD2} | Output Power Supply |

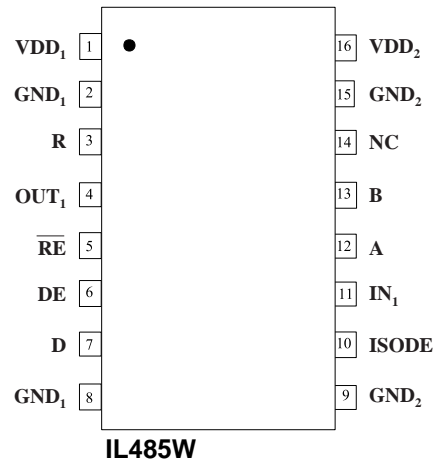

Driver Section

Electrical specifications are T_{min} to T_{max} and $V_{DD} = 4.5\text{ V}$ to 5.5 V unless otherwise stated.

| Parameters | Symbol | Min. | Typ. ⁽⁵⁾ | Max. | Units | Test Conditions |
|---|------------------|------|---------------------|---------------------|---------------|---|
| Input Clamp Voltage | V_{IK} | | | -1.5 | V | $I_L = -18\text{ mA}$ |
| Output voltage | V_O | 0 | | 6 | V | $I_O = 0$ |
| Differential Output Voltage ⁽²⁾ | $ V_{OD1} $ | 1.5 | | 6 | V | $I_O = 0$ |
| Differential Output Voltage ⁽²⁾ | $ V_{OD2} $ | 1.5 | 2.5 | 5 | V | $R_L = 54\ \Omega$, $V_{DD} = 5\text{ V}$ |
| Differential Output Voltage ⁽²⁾⁽⁶⁾ | V_{OD3} | 1.5 | | 5 | V | $R_L = 54\ \Omega$, $V_{DD} = 4.5\text{ V}$ |
| Change in Magnitude of Differential Output Voltage ⁽⁷⁾ | $\Delta V_{od} $ | | | ± 0.2 | V | $R_L = 54\ \Omega$ or $100\ \Omega$ |
| Common Mode Output Voltage | V_{oc} | | | 3 -1 | V | $R_L = 54\ \Omega$ or $100\ \Omega$ |
| Change in Magnitude of Common Mode Output Voltage ⁽⁷⁾ | $\Delta V_{oc} $ | | | ± 0.2 | V | $R_L = 54\ \Omega$ or $100\ \Omega$ |
| Output Current ⁽⁴⁾ <i>Output Disabled</i> | I_O | | | 1 -0.8 | mA | $V_O = 12\text{ V}$ $V_O = -7\text{ V}$ |
| High Level Input Current | I_{IH} | | | 10 | μA | $V_I = 3.5\text{ V}$ |
| Low Level Input Current | I_{IL} | | | -10 | μA | $V_I = 0.4\text{ V}$ |
| Short-circuit Output Current | I_{OS} | | | 250 -150 -250 | mA | $V_O = -6\text{ V}$ $V_O = 0\text{ V}$ $V_O = 8\text{ V}$ |
| Supply Current | I_{DD1} | | 4 | 6 | mA | No Load (Outputs Enabled) |

Switching Specifications

| Parameters | Symbol | Min. | Typ. ⁽⁵⁾ | Max. | Units | Test Conditions |
|--------------------------------------|----------------------|------|---------------------|------|-------|---|
| Maximum Data Rate | | 35 | | | Mbps | $R_L = 54\ \Omega$, $C_L = 50\text{ pF}$ |
| Differential Output Prop Delay | $t_D(\text{OD})$ | | 16 | 25 | ns | $R_L = 54\ \Omega$, $C_L = 50\text{ pF}$ |
| Pulse Skew ⁽¹⁰⁾ | $t_S(\text{P})$ | | 1 | 6 | ns | $R_L = 54\ \Omega$, $C_L = 50\text{ pF}$ |
| Differential Output Rise & Fall Time | $t_r(\text{OD})$ | | 8 | 10 | ns | $R_L = 54\ \Omega$, $C_L = 50\text{ pF}$ |
| Output Enable Time To High Level | t_{pZH} | | 31 | 65 | ns | $R_L = 54\ \Omega$, $C_L = 50\text{ pF}$ |
| Output Enable Time To Low Level | t_{pZL} | | 22 | 35 | ns | $R_L = 54\ \Omega$, $C_L = 50\text{ pF}$ |
| Output Disable Time From High Level | t_{pHZ} | | 28 | 50 | ns | $R_L = 54\ \Omega$, $C_L = 50\text{ pF}$ |
| Output Disable Time From Low Level | t_{pLZ} | | 16 | 32 | ns | $R_L = 54\ \Omega$, $C_L = 50\text{ pF}$ |
| Skew Limit ⁽³⁾ | $t_{SK}(\text{LIM})$ | | 2 | 12 | ns | $R_L = 54\ \Omega$, $C_L = 50\text{ pF}$ |

Notes (apply to both driver and receiver sections):

- All voltage values are with respect to network ground except differential I/O bus voltages.
- Differential input/output voltage is measured at the noninverting terminal A with respect to the inverting terminal B.
- Skew limit is the maximum propagation delay difference between any two devices at 25°C .
- The power-off measurement in ANSI Standard EIA/TIA-422-B applies to disabled outputs only and is not applied to combined inputs and outputs.
- All typical values are at $V_{DD1}, V_{DD2} = 5\text{ V}$ or $V_{DD1} = 3.3\text{ V}$ and $T_A = 25^\circ\text{C}$.
- The minimum V_{OD2} with a $100\ \Omega$ load is either $\frac{1}{2} V_{OD1}$ or 2 V , whichever is greater.
- $\Delta|V_{od}|$ and $\Delta|V_{oc}|$ are the changes in magnitude of V_{OD} and V_{oc} , respectively, that occur when the input is changed from one logic state to the other.
- This applies for both power on and power off, refer to ANSI standard RS-485 for exact condition. The EIA/TIA-422-B limit does not apply for a combined driver and receiver terminal.
- Includes 8 ns read enable time. Maximum propagation delay is 25 ns after read assertion.
- Pulse skew is defined as $|t_{PLH} - t_{PHL}|$ of each channel.
- The relevant test and measurement methods are given in the Electromagnetic Compatibility section on p. 6.
- External magnetic field immunity is improved by this factor if the field direction is "end-to-end" rather than to "pin-to-pin" (see diagram on p. 6).

Receiver Section

 Electrical specifications are T_{min} to T_{max} and $V_{DD} = 4.5\text{ V}$ to 5.5 V unless otherwise stated.

| Parameters | Symbol | Min. | Typ. ⁽⁵⁾ | Max. | Units | Test Conditions |
|--|-----------|----------------|---------------------|-----------|---------------|---|
| Positive-going Input Threshold Voltage | V_{IT+} | | | 0.2 | V | $V_o = 2.7\text{ V}$, $I_o = -0.4\text{ mA}$ |
| Negative-going Input Threshold Voltage | V_{IT-} | -0.2 | | | V | $V_o = 0.5\text{ V}$, $I_o = 8\text{ mA}$ |
| Hysteresis Voltage ($V_{IT+} - V_{IT-}$) | V_{HYS} | | 60 | | mV | |
| High Level Digital Output Voltage | V_{OH} | $V_{DD} - 0.2$ | | | V | $V_{ID} = 200\text{ mV}$ $I_{OH} = -20\text{ }\mu\text{A}$ |
| Low Level Digital Output Voltage | V_{OL} | | | 0.2 | V | $V_{ID} = -200\text{ mV}$ $I_{OH} = 20\text{ }\mu\text{A}$ |
| High-impedance-state output current | I_{OZ} | | | ± 20 | μA | $V_o = 0.4$ to $(V_{DD2} - 0.5)\text{ V}$ |
| Line Input Current ⁽⁸⁾ | I_i | | | 1 -0.8 | mA | $V_i = 12\text{ V}$ $V_i = -7\text{ V}$ Other Input ⁽¹¹⁾ = 0 V |
| Input Resistance | r_i | 12 | 20 | | k Ω | |
| Supply Current | I_{DD2} | | 27 | 34 | mA | No load Outputs Enabled |

Switching Characteristics

| Parameters | Symbol | Min. | Typ. ⁽⁵⁾ | Max. | Units | Test Conditions |
|-------------------------------------|---------------|------|---------------------|------|-------|---|
| Maximum Data Rate | | 35 | | | Mbps | $R_L = 54\text{ }\Omega$, $C_L = 50\text{ pF}$ |
| Propagation Delay ⁽⁹⁾ | t_{PD} | | 24 | 32 | ns | $V_o = -1.5\text{ V}$ to 1.5 V , $C_L = 15\text{ pF}$ |
| Pulse Skew ⁽¹⁰⁾ | $t_{SK(P)}$ | | 1 | 6 | ns | $V_o = -1.5\text{ V}$ to 1.5 V , $C_L = 15\text{ pF}$ |
| Skew Limit ⁽³⁾ | $t_{SK(LIM)}$ | | 2 | 8 | ns | $R_L = 54\text{ }\Omega$, $C_L = 50\text{ pF}$ |
| Output Enable Time To High Level | t_{PZH} | | 17 | 24 | ns | $C_L = 15\text{ pF}$ |
| Output Enable Time To Low Level | t_{PZL} | | 30 | 45 | ns | $C_L = 15\text{ pF}$ |
| Output Disable Time From High Level | t_{PHZ} | | 30 | 45 | ns | $C_L = 15\text{ pF}$ |
| Output Disable Time From Low Level | t_{PLZ} | | 18 | 27 | ns | $C_L = 15\text{ pF}$ |

Magnetic Field Immunity⁽¹¹⁾

| Magnetic Field Immunity at 5 V | | | | | | |
|--|-----------|------|------|--|-----|----------------------|
| Power Frequency Magnetic Immunity | H_{PF} | 2800 | 3500 | | A/m | 50Hz/60Hz |
| Pulse Magnetic Field Immunity | H_{PM} | 4000 | 4500 | | A/m | $t_p = 8\mu\text{s}$ |
| Damped Oscillatory Magnetic Field | H_{OSC} | 4000 | 4500 | | A/m | 0.1Hz – 1MHz |
| Cross-axis Immunity Multiplier ⁽¹²⁾ | K_X | | 2.5 | | | |
| Magnetic Field Immunity at 3.3 V | | | | | | |
| Power Frequency Magnetic Immunity | H_{PF} | 1000 | 1500 | | A/m | 50Hz/60Hz |
| Pulse Magnetic Field Immunity | H_{PM} | 1800 | 2000 | | A/m | $t_p = 8\mu\text{s}$ |
| Damped Oscillatory Magnetic Field | H_{OSC} | 1800 | 2000 | | A/m | 0.1Hz – 1MHz |
| Cross-axis Immunity Multiplier ⁽¹²⁾ | K_X | | 2.5 | | | |

Electrostatic Discharge Sensitivity

This product has been tested for electrostatic sensitivity to the limits stated in the specifications. However, NVE recommends that all integrated circuits be handled with appropriate care to avoid damage. Damage caused by inappropriate handling or storage could range from performance degradation to complete failure.

Application Information

Electromagnetic Compatibility

The IL485W is fully compliant with generic EMC standards EN50081, EN50082-1 and the umbrella line-voltage standard for Information Technology Equipment (ITE) EN61000. The IsoLoop Isolator's Wheatstone bridge configuration and differential magnetic field signaling ensure excellent EMC performance against all relevant standards. NVE conducted compliance tests in the categories below:

EN50081-1

Residential, Commercial & Light Industrial
 Methods EN55022, EN55014

EN50082-2: Industrial Environment

Methods EN61000-4-2 (ESD), EN61000-4-3 (Electromagnetic Field Immunity), EN61000-4-4 (Electrical Transient Immunity), EN61000-4-6 (RFI Immunity), EN61000-4-8 (Power Frequency Magnetic Field Immunity), EN61000-4-9 (Pulsed Magnetic Field), EN61000-4-10 (Damped Oscillatory Magnetic Field)

ENV50204

Radiated Field from Digital Telephones (Immunity Test)

Immunity to external magnetic fields is even higher if the field direction is "end-to-end" (rather than to "pin-to-pin") as shown in the diagram at right.

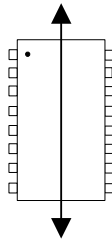

Dynamic Power Consumption

IsoLoop Isolators achieve their low power consumption from the way they transmit data across the isolation barrier. By detecting the edge transitions of the input logic signal and converting these to narrow current pulses, a magnetic field is created around the GMR Wheatstone bridge. Depending on the direction of the magnetic field, the bridge causes the output comparator to switch following the input logic signal. Since the current pulses are narrow, about 2.5 ns, the power consumption is independent of mark-to-space ratio and solely dependent on frequency. This has obvious advantages over optocouplers, which have power consumption heavily dependent on frequency and time.

The approximate power supply current per channel is:

$$I_{IN} = 40 \times \frac{f}{f_{MAX}} \times \frac{1}{4} \text{ mA}$$

Where f = operating frequency

$$f_{MAX} = 50 \text{ MHz}$$

Power Supply Decoupling

Both V_{DD1} and V_{DD2} must be bypassed with 47 nF ceramic capacitors. These should be placed as close as possible to V_{DD} pins for proper operation. Additionally, V_{DD2} should be bypassed with a 10 μ F tantalum capacitor.

Application

PROFIBUS Fault Interrogation

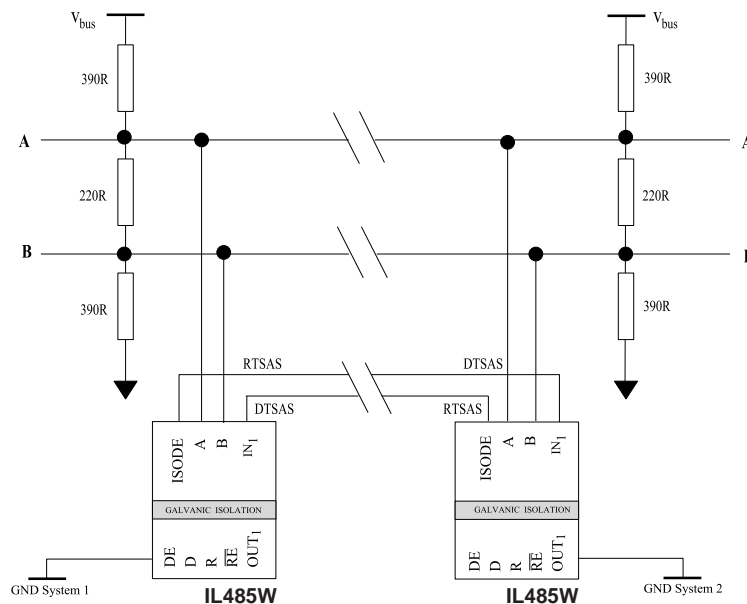

0.3" 16-pin SOIC Package

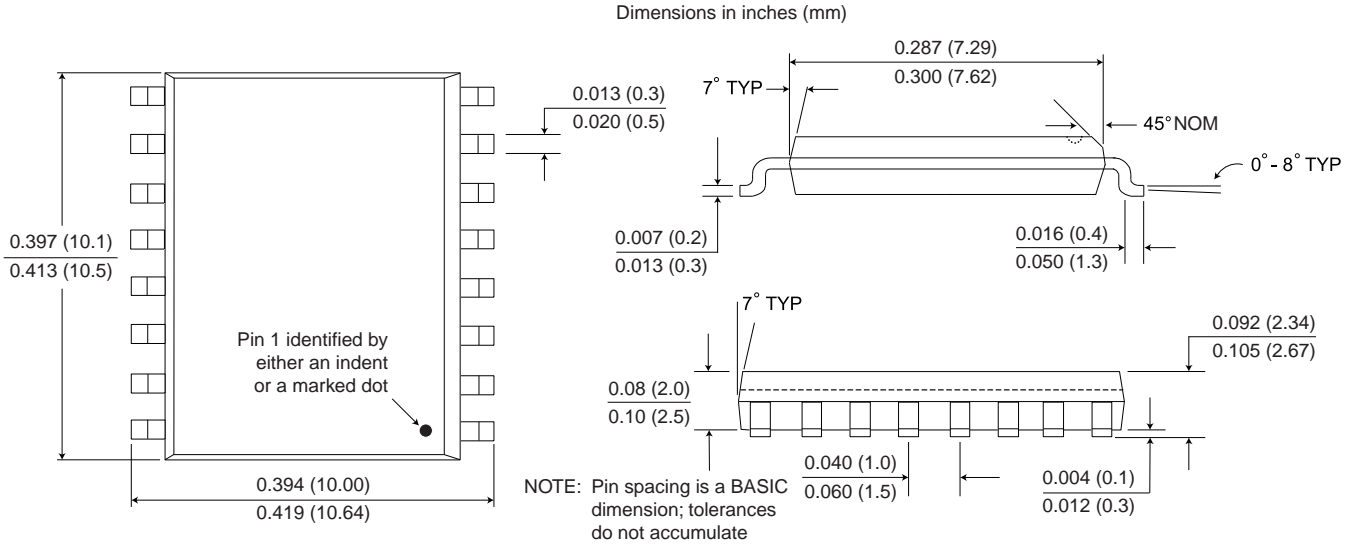

Ordering Information and Valid Part Numbers

IL 485W E TR13

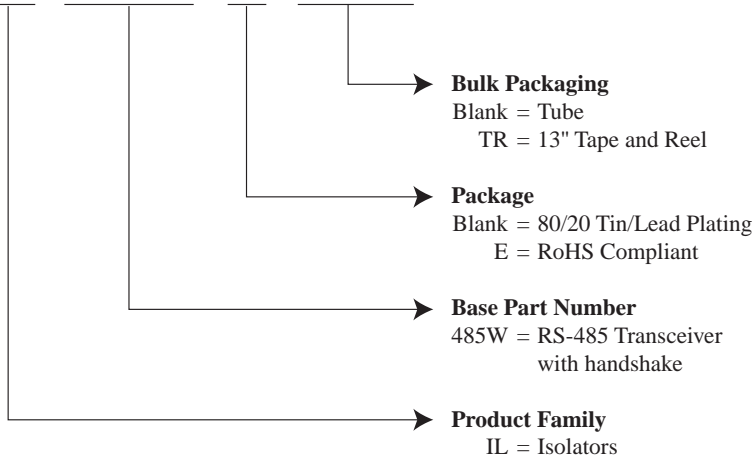

Valid Part Numbers

IL485W
IL485WE

All IL485W part types are available on tape and reel.



ISB-DS-001-IL485W-N

March 2008

Changes

- Added magnetic field immunity and electromagnetic compatibility specifications.
- Added note on package drawing that pin-spacing tolerances are non-accumulating.

ISB-DS-001-IL485W-M

Changes

- Changed ordering information to reflect that devices are now fully RoHS compliant with no exemptions.

ISB-DS-001-IL485W-L

Changes

- Reorganized supply current specifications; misc. minor changes

ISB-DS-001-IL485W-K

April 2007

Changes

- Eliminated soldering profile chart

ISB-DS-001-IL485W-J

December 2006

Changes

- Updated open input state in truth table

ISB-DS-001-IL485W-I

Changes

- Updated package drawing; misc.

ISB-DS-001-IL485W-H

Changes

- Update UL and IEC approvals

ISB-DS-001-IL485W-G

Changes

- Revision letter added.
- Ordering Information removed.
- IEC 61010-1 Classification "Reinforced Insulation" added.
- Notes added.
- Electrostatic Discharge Sensitivity note moved to page 5.
- Electrostatic Discharge Sensitivity Note added.
- Notes moved to page 3.
- Ordering Information added.

About NVE

An ISO 9001 Certified Company

NVE Corporation manufactures innovative products based on unique spintronic Giant Magnetoresistive (GMR) technology. Products include Magnetic Field Sensors, Magnetic Field Gradient Sensors (Gradiometers), Digital Magnetic Field Sensors, Digital Signal Isolators, and Isolated Bus Transceivers.

NVE pioneered spintronics and in 1994 introduced the world's first products using GMR material, a line of ultra-precise magnetic sensors for position, magnetic media, gear speed and current sensing.

NVE Corporation
11409 Valley View Road
Eden Prairie, MN 55344-3617 USA
Telephone: (952) 829-9217
Fax: (952) 829-9189
Internet: www.nve.com
e-mail: isoinfo@nve.com

The information provided by NVE Corporation is believed to be accurate. However, no responsibility is assumed by NVE Corporation for its use, nor for any infringement of patents, nor rights or licenses granted to third parties, which may result from its use. No license is granted by implication, or otherwise, under any patent or patent rights of NVE Corporation. NVE Corporation does not authorize, nor warrant, any NVE Corporation product for use in life support devices or systems or other critical applications, without the express written approval of the President of NVE Corporation.

ISB-DS-001-IL485W-N

March 2008