

Excellent Integrated System Limited

Stocking Distributor

Click to view price, real time Inventory, Delivery & Lifecycle Information:

[Molex Connector Corporation](#)
[0905722161](#)

For any questions, you can email us directly:

sales@integrated-circuit.com

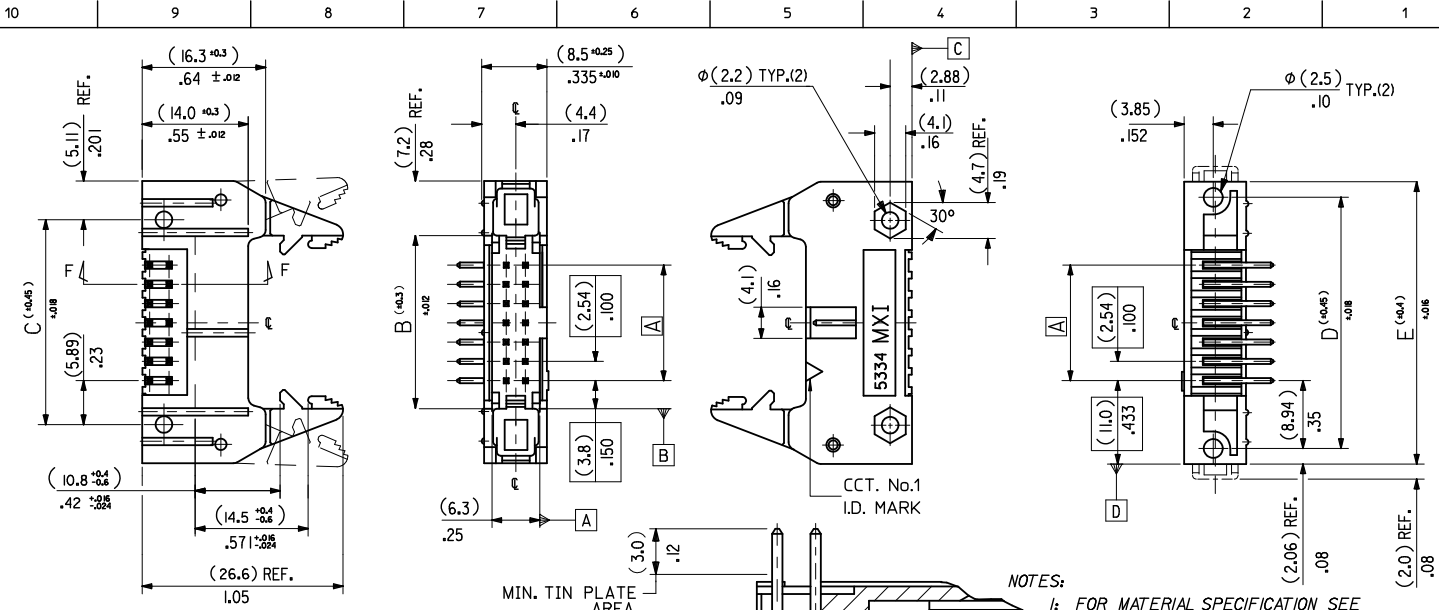

MIN. TIN PLATE AREA.

MIN. GOLD PLATE AREA.

- NOTES:**
- 1: FOR MATERIAL SPECIFICATION SEE NOTE 1 ON SHEET 2.
 - 2: FOR RECOMMENDED P.C.B.HOLE PATTERN, PART No's AND UNSTATED DIMENSIONS SEE SHEET 2.
 - 3: PRODUCT SPEC.No.: PS-99020-001/5.
- MEASURE POINT FOR GOLD PLATING THICKNESS TYP.

DETAIL A
DIMENSIONS FOR SELECTIVE PLATING'S, SCALE 4:1

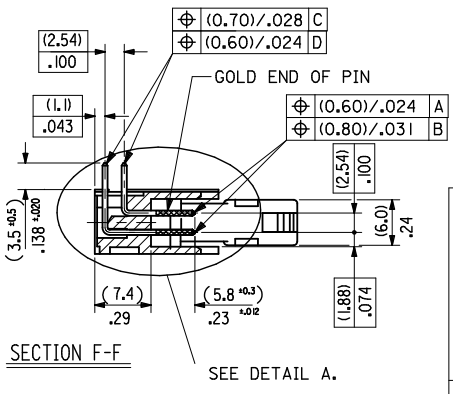

REMOVED REFS TO COLOR STAMP EC NO: E2011-0063 DRAWN: JOCONNOR CHKD: EFOLAN APPR: EFOLAN 2010/08/10 2010/08/25 2010/08/30	QUALITY SYMBOLS	GENERAL TOLERANCES (UNLESS SPECIFIED)	DIMENSION STYLE	SCALE	DESIGN UNITS	THIRD ANGLE PROJECTION
	▽=0 ▽=0	4 PLACES ± --- ± --- 3 PLACES ± --- ± .008 2 PLACES ± 0.20 ± .008 1 PLACE ± 0.20 ± --- ANGULAR ± 1/2°	MM/IN	2:1	METRIC	DRAWN BY: POB DATE: 1990/09/12 CHECKED BY: _____ DATE: _____ APPROVED BY: EFOLAN DATE: 2010/08/25 MATERIAL NO.: ENTER PART DOCUMENT NO.: SDA-90572
	DRAFT WHERE APPLICABLE MUST REMAIN WITHIN DIMENSIONS	THIS DRAWING CONTAINS INFORMATION THAT IS PROPRIETARY TO MOLEX INCORPORATED AND SHOULD NOT BE USED WITHOUT WRITTEN PERMISSION	TITLE: QIK FLECS R/A HEADER DIN EJECT LEVERS FOR IMPROVED WIPE FEMALE MOLEX INCORPORATED	SHEET NO.: 1 OF 4		

10 9 8 7 6 5 4 3 2 1

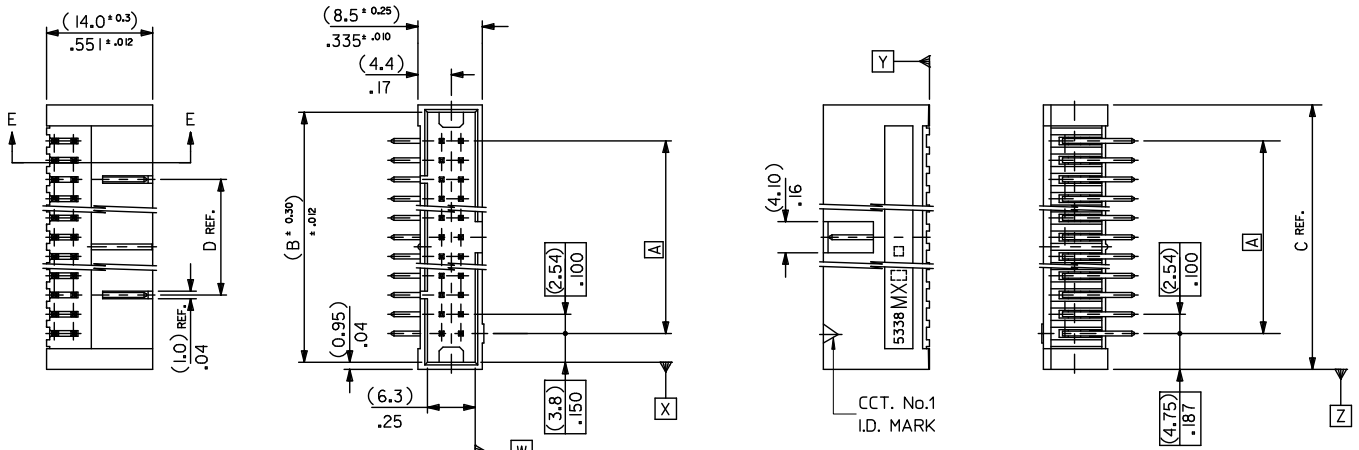

- NOTES:**
- 1: FOR MATERIAL SPECIFICATION SEE NOTE 1. ON SHEET 4.
 - 2: FOR RECOMMENDED P.C.B.HOLE PATTERN, PART No's AND UNSTATED DIMENSIONS SEE SHEET 4.
 - 3: PRODUCT SPEC. No. : PS-99020-0015.

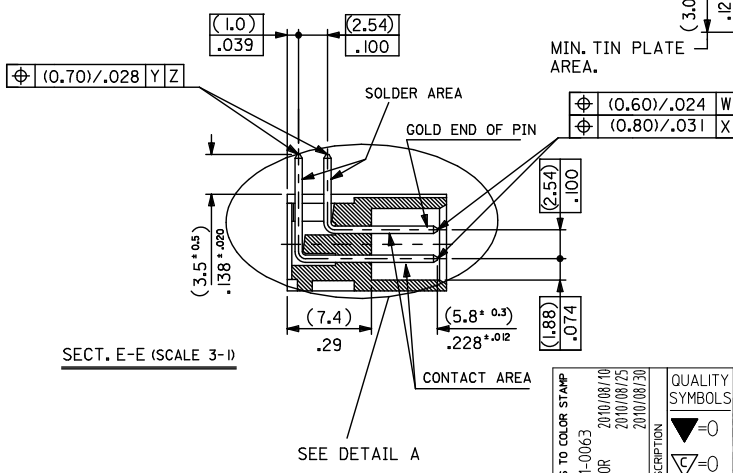

DETAIL A
DIMENSIONS FOR SELECTIVE PLATING'S, SCALE 4:1

REMOVED REFS TO COLOR STAMP EC NO.: E2011-0063 DRAWN: JOCONNOR CHKD: 2010/08/25 APPR: EFOLAN 2010/08/30	QUALITY SYMBOLS ▽=0 ▽=0	GENERAL TOLERANCES (UNLESS SPECIFIED)		DIMENSION STYLE		SCALE	DESIGN UNITS	THIRD ANGLE PROJECTION	
		mm	INCH	MM/IN	DATE	2:1	METRIC		
D	REV	4 PLACES	± ---	± ---	DRAWN BY	DATE	TITLE QIK FLECS RIGHT ANGLE HEADER FOR IMPROVED WIPE FEMALE		
		3 PLACES	± ---	± .008	POB	1990/09/17			
		2 PLACES	± 0.20	± .008	CHECKED BY	DATE	MOLEX INCORPORATED		
		1 PLACE	± 0.20	± ---	APPROVED BY	DATE			
		ANGULAR ± 1/2°			EFOLAN	2010/08/25	MATERIAL NO. ENTER PART DOCUMENT NO. SDA-90572		
		DRAFT WHERE APPLICABLE MUST REMAIN WITHIN DIMENSIONS							
				SIZE	THIS DRAWING CONTAINS INFORMATION THAT IS PROPRIETARY TO MOLEX INCORPORATED AND SHOULD NOT BE USED WITHOUT WRITTEN PERMISSION				
				A3					
								SHEET NO. 3 OF 4	

9 8 7 6 5 4 3 2 1

10 9 8 7 6 5 4 3 2 1

(78.74)/3.100	(86.34)/3.400	(88.24)/3.474	(63.50)/2.500	90572-2641	90572-2642	90572-2643		64
(73.66)/2.900	(81.26)/3.200	(83.16)/3.274	(50.80)/2.000	-2601	-2602	-2603		60
(60.96)/2.400	(68.56)/2.700	(70.46)/2.774	(38.10)/1.500	-2501	-2502	-2503	90572-2509	50
(48.26)/1.900	(55.86)/2.200	(57.76)/2.274	(33.02)/1.300	-2401	-2402	-2403	-2409	40
(40.64)/1.600	(48.24)/1.900	(50.14)/1.974	(30.48)/1.200	-2341	-2342	-2343	-2349	34
(35.56)/1.400	(43.16)/1.700	(45.06)/1.774	(25.40)/1.000	-2301	-2302	-2303	-1309	30
(30.48)/1.200	(38.08)/1.500	(39.98)/1.547		-2261	-2262	-2263	-2269	26
(22.86)/.900	(30.46)/1.200	(32.36)/1.274		-2201	-2202	-2203	-1209	20
(17.78)/.700	(25.38)/1.000	(27.28)/1.074		-2161	-2162	-2163	-2169	16
(15.24)/.600	(22.84)/.900	(24.74)/.974		-2141	-2142	-2143	-2149	14
(10.16)/.400	(17.76)/.700	(19.66)/.774		90572-2101	90572-2102	90572-2103	90572-2109	10
A	B	C	D	ENG. NO. GSI PLATING	ENG. NO. GS2 PLATING	ENG. NO. GS3 PLATING	ENG. NO. PRE TIN	No. of CKTS.

NOTES

1. MATERIAL

HEADER : GLASS FILLED POLYESTER (UL 94V0), COLOUR - BLACK.
PINS : BRASS SIZE # (0.635)/.025 .
LEVER : GLASS FILLED POLYESTER (UL 94V0), COLOUR - BLACK.
SPRING PINS : STEEL

2. PLATING OPTIONS.

90572-2**1, (1um)/39uin MIN. NICKEL UNDERPLATE, CONTACT AREA
GSI PLATING (0.1um)/4uin MIN. GOLD, SOLDER AREA (3um)/118uin MIN.
TIN.
90572-2**2, (1um)/39uin MIN. NICKEL UNDERPLATE, CONTACT AREA
GS2 PLATING (0.76um)/30uin MIN. GOLD, SOLDER AREA (3um)/118uin MIN.
TIN.
90572-2**3, (1um)/39uin MIN. NICKEL UNDERPLATE, CONTACT AREA
GS3 PLATING (0.25um)/10uin MIN. GOLD, SOLDER AREA (3um)/118uin MIN.
TIN.
90572-2**9, (0.5-1um)/20-40uin NICKEL UNDER (1.0-3.0um)/39-118uin TIN.
PRE-TIN

3. 10.2mm MAX. TO EDGE OF PCB FOR DAISY CHAIN APPLICATIONS.

4. RECOMMENDED PCB THICKNESS 1.6mm

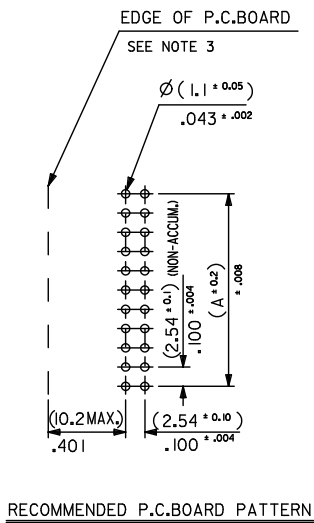

RECOMMENDED P.C. BOARD PATTERN

REMOVED REFS TO COLOR STAMP EC NO: E2011-0063 DRAWN: JOCONOR CHKD: EFOLAN APPR: EFOLAN REV: D	2010/08/10 2010/08/25 2010/08/30	QUALITY SYMBOLS ▼=0 ▽=0	GENERAL TOLERANCES (UNLESS SPECIFIED) mm INCH 4 PLACES ± --- ± --- 3 PLACES ± --- ± .008 2 PLACES ± 0.20 ± .008 1 PLACE ± 0.20 ± --- ANGULAR ± 1/2°	DIMENSION STYLE MM/IN DRAWN BY DATE POB 1990/07/17 CHECKED BY DATE APPROVED BY DATE EFOLAN 2010/08/25 MATERIAL NO. SEE CHART SIZE 3 THIS DRAWING CONTAINS INFORMATION THAT IS PROPRIETARY TO MOLEX INCORPORATED AND SHOULD NOT BE USED WITHOUT WRITTEN PERMISSION	SCALE 2:1 DESIGN UNITS METRIC THIRD ANGLE PROJECTION	TITLE QIK FLECS RIGHT ANGLE HEADER FOR IMPROVED WIPE FEMALE MOLEX INCORPORATED DOCUMENT NO. SDA-90572 SHEET NO. 4 OF 4
--	--	-------------------------------	---	---	--	--

9 8 7 6 5 4 3 2 1