

Excellent Integrated System Limited

Stocking Distributor

Click to view price, real time Inventory, Delivery & Lifecycle Information:

[STMicroelectronics](#)

[STL60N10F7](#)

For any questions, you can email us directly:

sales@integrated-circuit.com



STL60N10F7

N-channel 100 V, 0.0145 Ω typ., 12 A, STripFET™ VII DeepGATE™ Power MOSFET in a PowerFLAT™ 5x6 package

Datasheet - production data

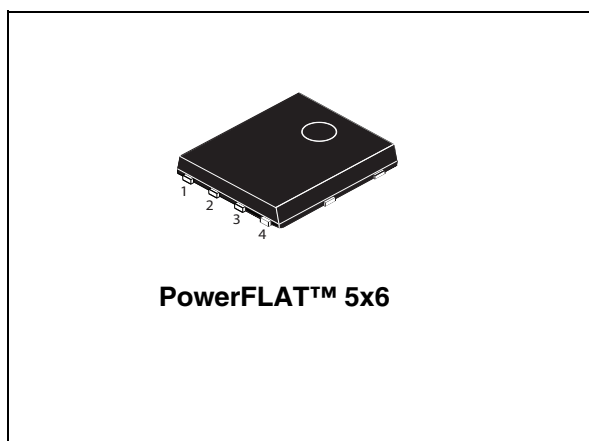
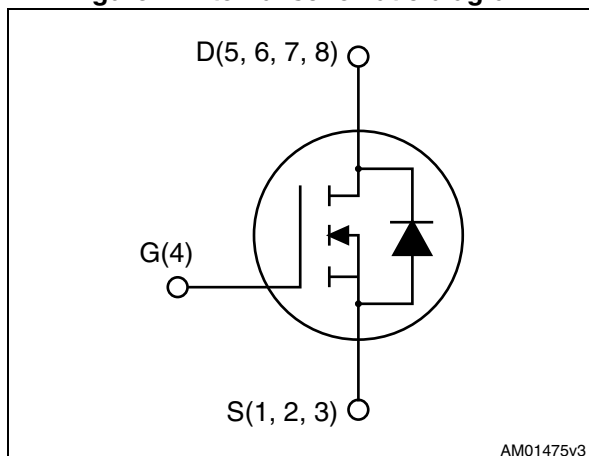

Figure 1. Internal schematic diagram



Features

Order code	V _{DS}	R _{DS(on)} max	I _D	P _{TOT}
STL60N10F7	100 V	0.018 Ω	12 A	5 W

- Ultra low on-resistance
- 100% avalanche tested

Applications

- Switching applications

Description

This device is an N-channel Power MOSFET developed using the 7th generation of STripFET™ DeepGATE™ technology, with a new gate structure. The resulting Power MOSFET exhibits the lowest R_{DS(on)} in all packages.

Table 1. Device summary

Order code	Marking	Package	Packaging
STL60N10F7	60N10F7	PowerFLAT™ 5x6	Tape and reel

Contents

1	Electrical ratings	3
2	Electrical characteristics	4
2.1	Electrical characteristics (curves)	6
3	Test circuits	8
4	Package mechanical data	9
5	Packaging mechanical data	13
6	Revision history	15

1 Electrical ratings

Table 2. Absolute maximum ratings

Symbol	Parameter	Value	Unit
V_{DS}	Drain-source voltage	100	V
V_{GS}	Gate-source voltage	20	V
$I_D^{(1)}$	Drain current (continuous) at $T_C = 25\text{ }^\circ\text{C}$	46	A
$I_D^{(1)}$	Drain current (continuous) at $T_C = 100\text{ }^\circ\text{C}$	33	A
$I_D^{(2)}$	Drain current (continuous) at $T_{pcb} = 25\text{ }^\circ\text{C}$	12	A
$I_D^{(2)}$	Drain current (continuous) at $T_{pcb} = 100\text{ }^\circ\text{C}$	9	A
$I_{DM}^{(2)(3)}$	Drain current (pulsed)	48	A
$P_{TOT}^{(1)}$	Total dissipation at $T_C = 25\text{ }^\circ\text{C}$	72	W
$P_{TOT}^{(2)}$	Total dissipation at $T_{pcb} = 25\text{ }^\circ\text{C}$	5	W
T_J	Operating junction temperature	-55 to 175	$^\circ\text{C}$
T_{stg}	Storage temperature		$^\circ\text{C}$

1. This value is rated according to R_{thj-c} .
2. This value is rated according to $R_{thj-pcb}$.
3. Pulse width limited by safe operating area.

Table 3. Thermal resistance

Symbol	Parameter	Value	Unit
$R_{thj-pcb}^{(1)}$	Thermal resistance junction-pcb	31	$^\circ\text{C}/\text{W}$
R_{thj-c}	Thermal resistance junction-case	2.08	$^\circ\text{C}/\text{W}$

1. When mounted on FR-4 board of 1inch², 2oz Cu, t < 10 sec

Electrical characteristics

STL60N10F7

2 Electrical characteristics

(T_{CASE}=25 °C unless otherwise specified)

Table 4. On/off states

Symbol	Parameter	Test conditions	Min.	Typ.	Max.	Unit
V _{(BR)DSS}	Drain-source breakdown voltage (V _{GS} = 0)	I _D = 1 mA	100	-		V
I _{DSS}	Zero gate voltage drain current (V _{GS} = 0)	V _{DS} = 100 V V _{DS} = 100 V; T _C =125 °C		-	1 100	μA μA
I _{GSS}	Gate body leakage current (V _{DS} = 0)	V _{GS} = 20 V		-	100	nA
V _{GS(th)}	Gate threshold voltage	V _{DS} = V _{GS} , I _D = 250 μA	2.5		4.5	V
R _{DS(on)}	Static drain-source on-resistance	V _{GS} = 10 V, I _D = 6 A		0.0145	0.018	Ω

Table 5. Dynamic

Symbol	Parameter	Test conditions	Min.	Typ.	Max.	Unit
C _{iss}	Input capacitance	V _{DS} = 50 V, f = 1 MHz, V _{GS} = 0	-	1640	-	pF
C _{oss}	Output capacitance		-	360	-	pF
C _{rss}	Reverse transfer capacitance		-	25	-	pF
Q _g	Total gate charge	V _{DD} = 50 V, I _D = 12 A V _{GS} = 10 V <i>Figure 14</i>	-	25	-	nC
Q _{gs}	Gate-source charge		-	12	-	nC
Q _{gd}	Gate-drain charge		-	5	-	nC
Q _{oss}	Output charge	V _{DD} = 40 V, V _{GS} = 0V	-	28	-	nC

Table 6. Switching times

Symbol	Parameter	Test conditions	Min.	Typ.	Max.	Unit
t _{d(on)}	Turn-on delay time	V _{DD} = 50 V, I _D = 6 A, R _G = 4.7 Ω, V _{GS} = 10 V <i>Figure 13</i>	-	15	-	ns
t _r	Rise time		-	17	-	ns
t _{d(off)}	Turn-off delay time		-	24	-	ns
t _f	Fall time		-	8	-	ns

STL60N10F7
Electrical characteristics
Table 7. Source drain diode

Symbol	Parameter	Test conditions	Min	Typ.	Max	Unit
I_{SD}	Source-drain current		-		12	A
$I_{SDM}^{(1)}$	Source-drain current (pulsed)		-		48	A
$V_{SD}^{(2)}$	Forward on voltage	$I_{SD} = 12\text{ A}, V_{GS} = 0$	-		1.1	V
t_{rr}	Reverse recovery time	$I_{SD} = 12\text{ A},$ $di/dt = 100\text{ A}/\mu\text{s},$ $V_{DD} = 50\text{ V}, T_j = 150\text{ }^\circ\text{C}$	-	53		ns
Q_{rr}	Reverse recovery charge		-	67		nC
I_{RRM}	Reverse recovery current		-	2.5		A

1. Pulse width limited by safe operating area
2. Pulsed: pulse duration=300 μs , duty cycle 1.5%

Electrical characteristics

STL60N10F7

2.1 Electrical characteristics (curves)

Figure 2. Safe operating area

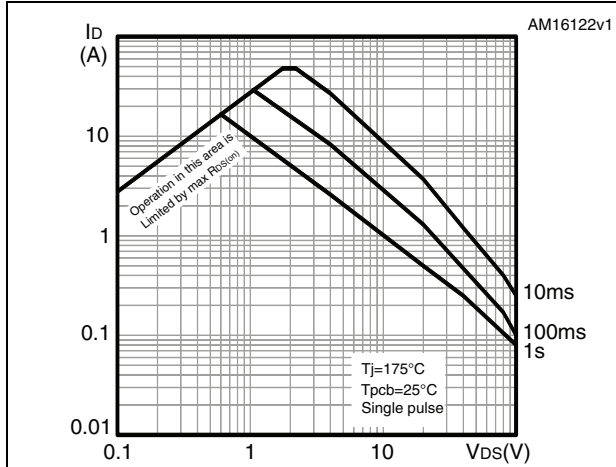

Figure 3. Thermal impedance

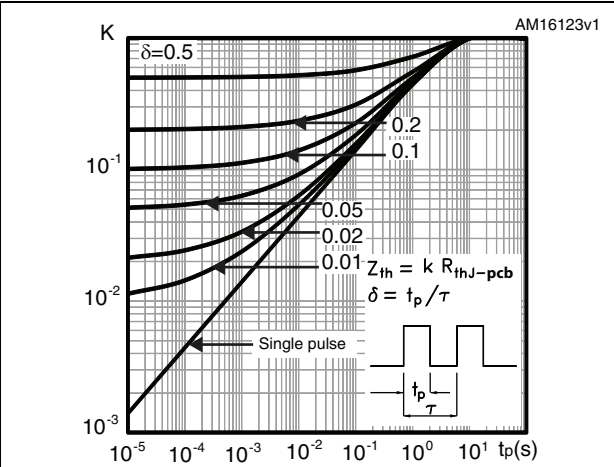

Figure 4. Output characteristics

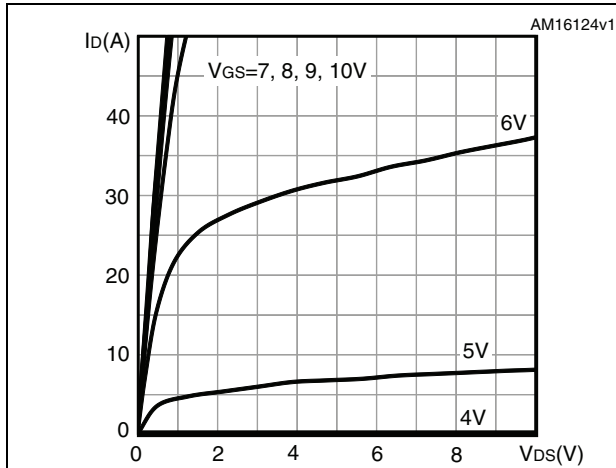

Figure 5. Transfer characteristics

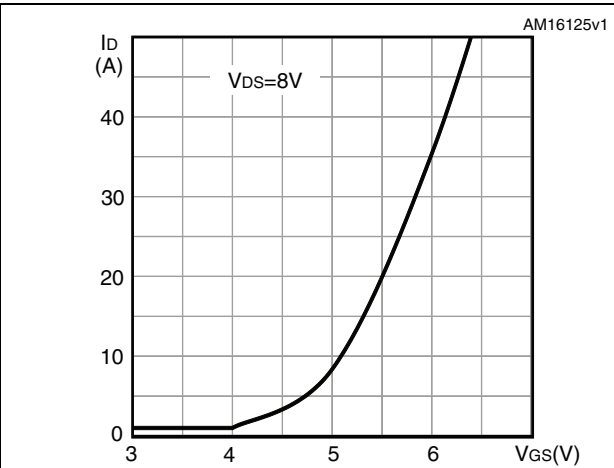

Figure 6. Gate charge vs gate-source voltage

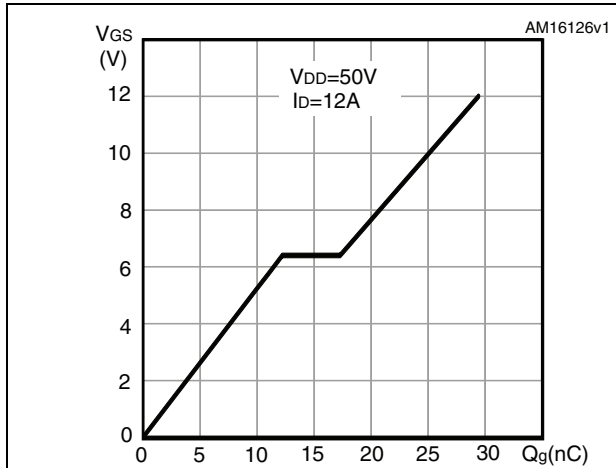
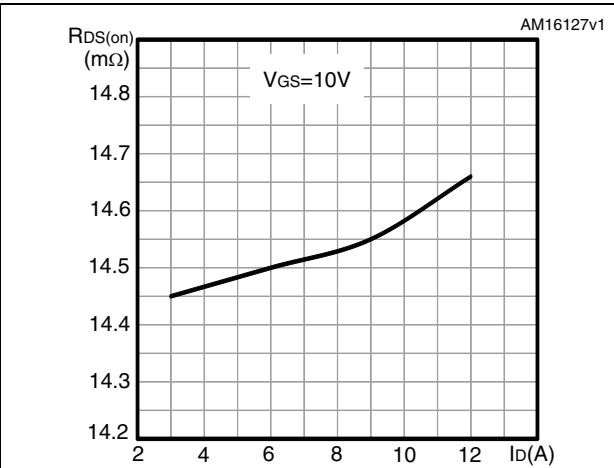

Figure 7. Static drain-source on-resistance



STL60N10F7

Electrical characteristics

Figure 8. Capacitance variations

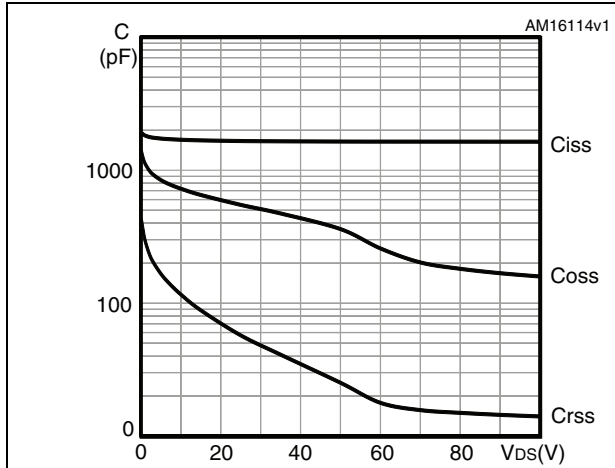

Figure 9. Normalized gate threshold voltage vs temperature

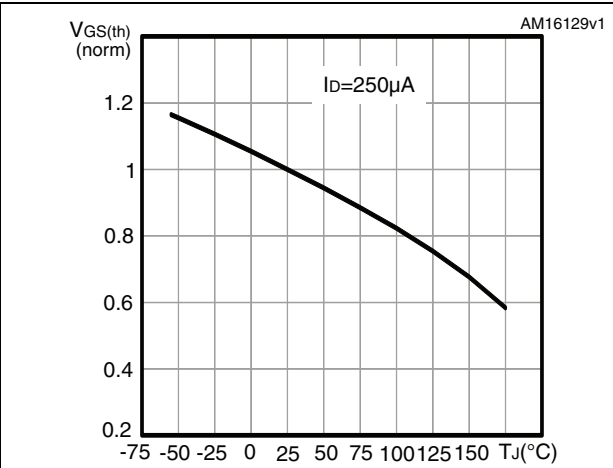

Figure 10. Normalized on-resistance vs temperature

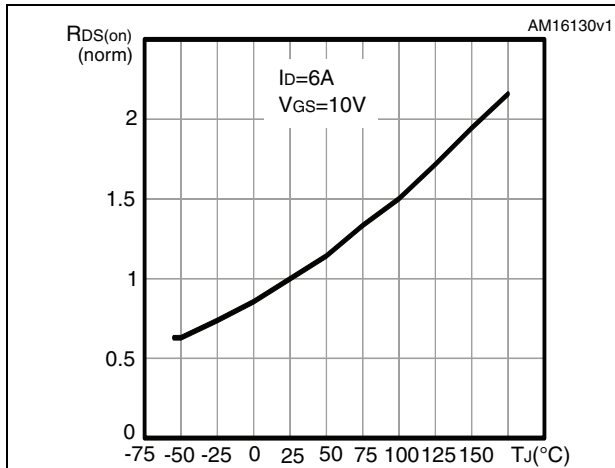

Figure 11. Source-drain diode forward characteristics

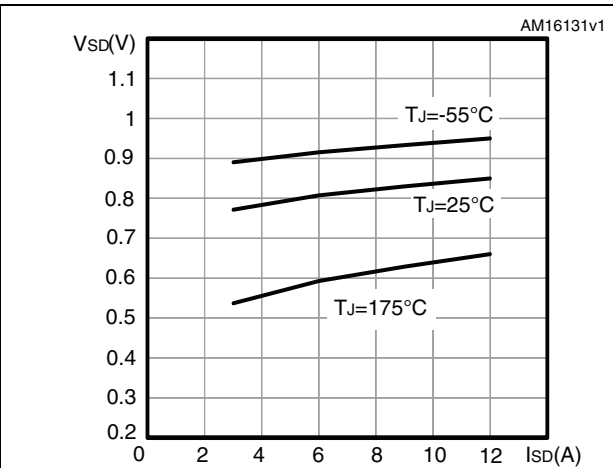
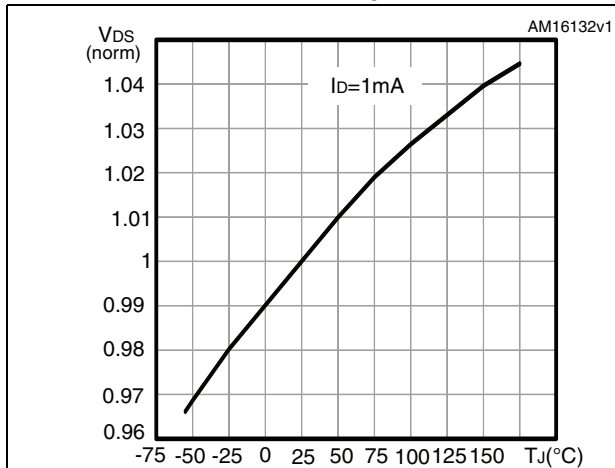

Figure 12. Normalized VDS vs temperature



3 Test circuits

Figure 13. Switching times test circuit for resistive load

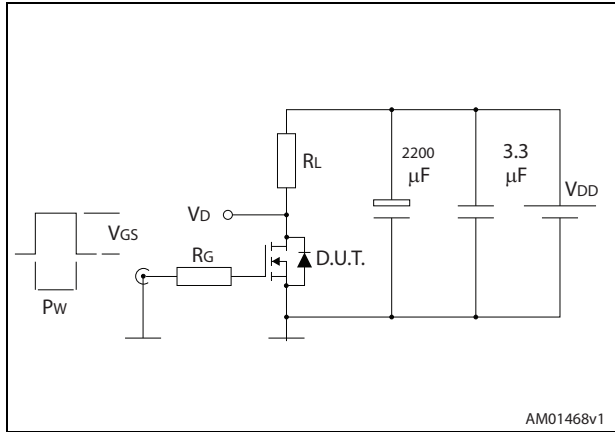

Figure 14. Gate charge test circuit

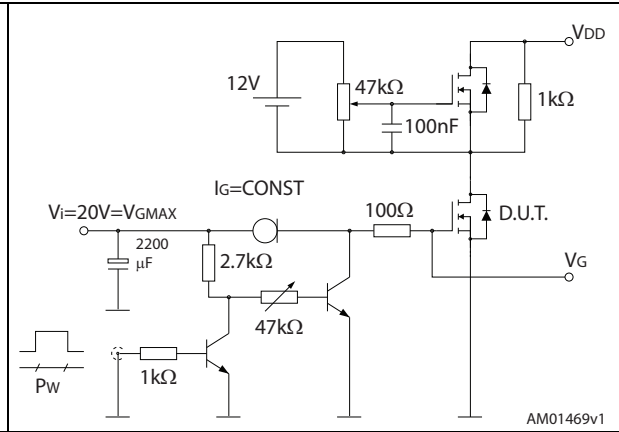

Figure 15. Test circuit for inductive load switching and diode recovery times

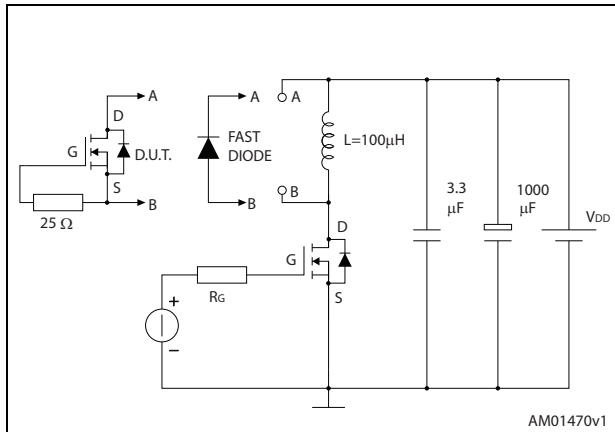

Figure 16. Unclamped inductive load test circuit

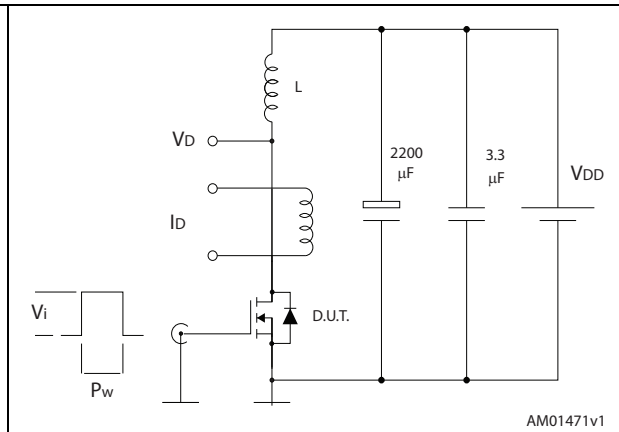

Figure 17. Unclamped inductive waveform

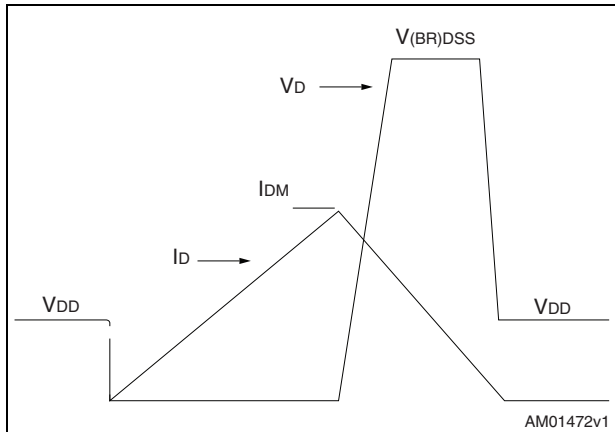
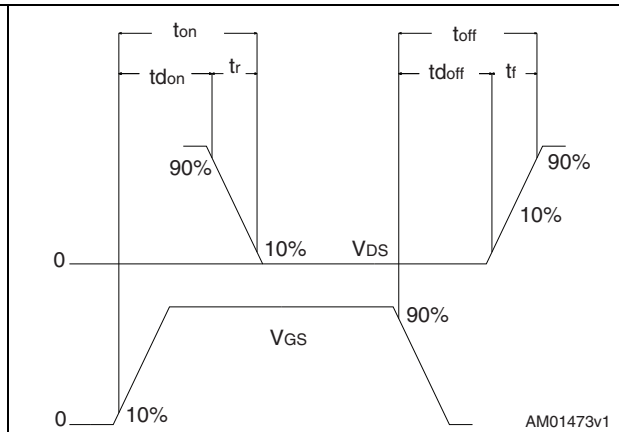

Figure 18. Switching time waveform



4 Package mechanical data

In order to meet environmental requirements, ST offers these devices in different grades of ECOPACK[®] packages, depending on their level of environmental compliance. ECOPACK[®] specifications, grade definitions and product status are available at: www.st.com. ECOPACK[®] is an ST trademark.

Package mechanical data

STL60N10F7

Table 8. PowerFLAT 5x6 type S-R mechanical data

Dim.	mm		
	Min.	Typ.	Max.
A	0.80		1.00
A1	0.02		0.05
A2		0.25	
b	0.30		0.50
D	5.00	5.20	5.40
E	5.95	6.15	6.35
D2	4.11		4.31
E2	3.50		3.70
e		1.27	
L	0.60		0.80
K	1.275		1.575

STL60N10F7

Package mechanical data

Figure 19. PowerFLAT™ 5x6 type S-R drawing

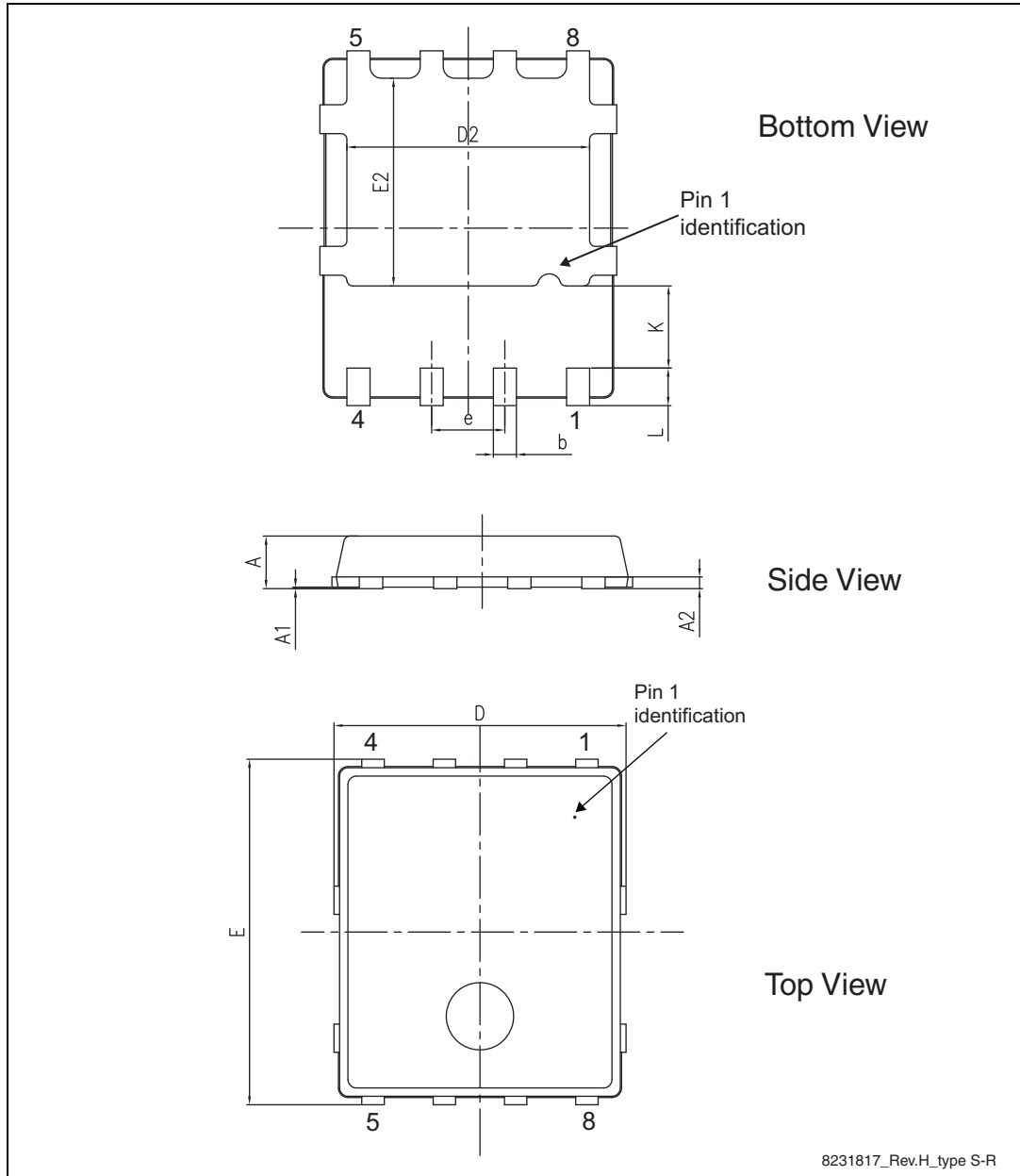

Package mechanical data

STL60N10F7

Figure 20. PowerFLAT™ 5x6 recommended footprint (dimensions are in mm)

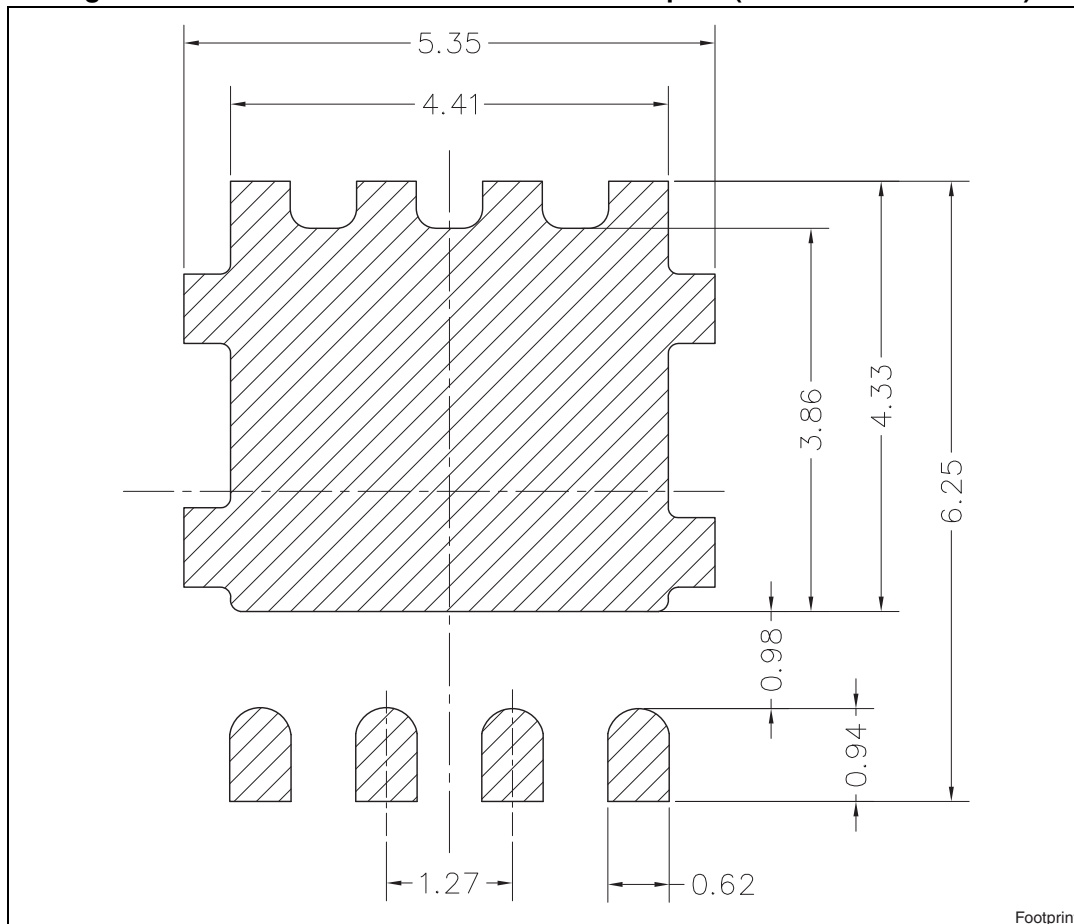

5 Packaging mechanical data

Figure 21. PowerFLAT™ 5x6 tape^(a)

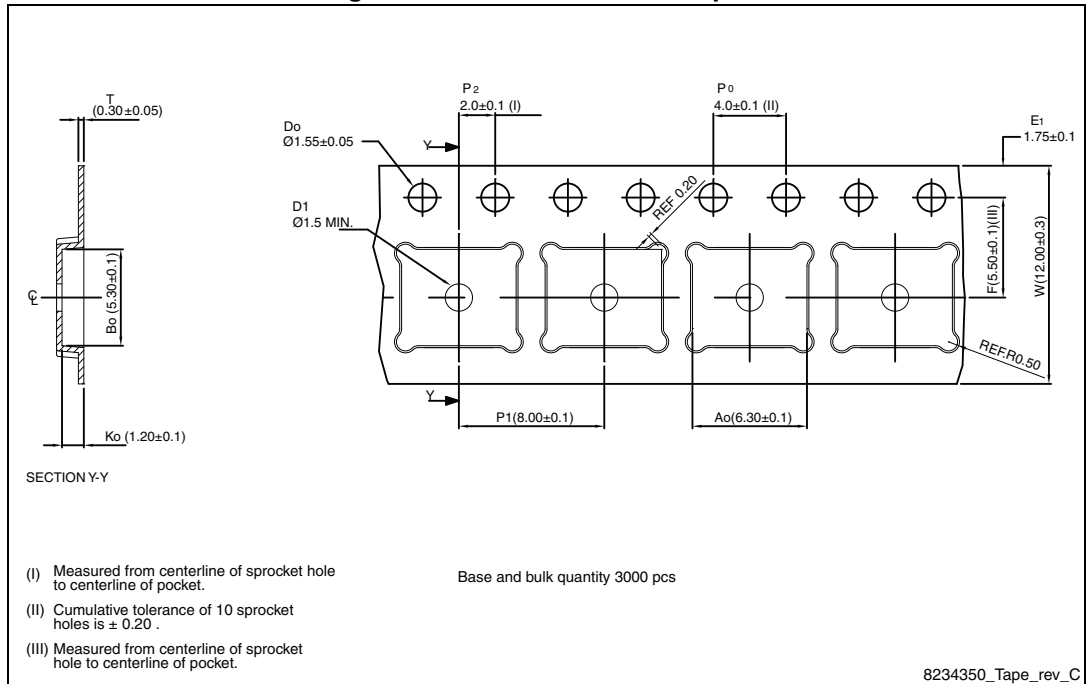
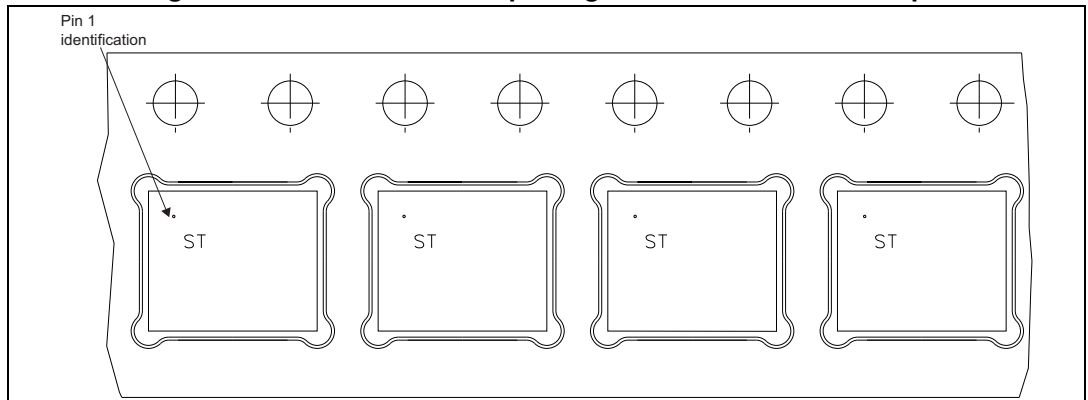

Figure 22. PowerFLAT™ 5x6 package orientation in carrier tape.



a. All dimensions are in millimeters.

Packaging mechanical data

STL60N10F7

Figure 23. PowerFLAT™ 5x6 reel

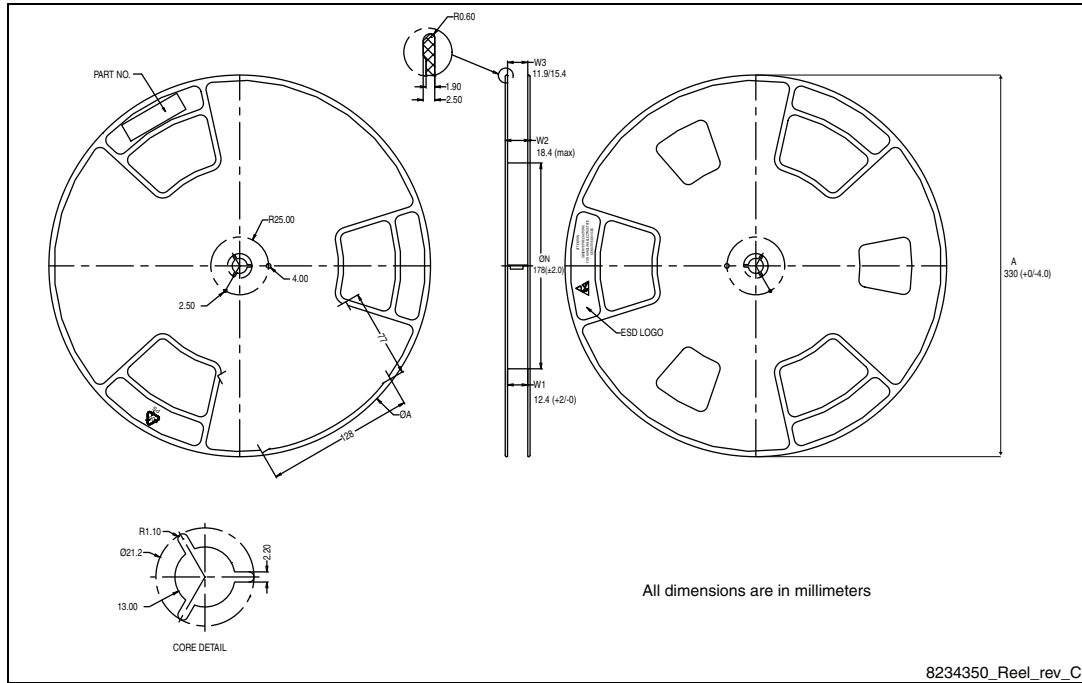

6 Revision history

Table 9. Document revision history

Date	Revision	Changes
29-Mar-2013	1	First release.
23-May-2013	2	<ul style="list-style-type: none"> – Document status promoted from target data to production data – Modified: $V_{GS(th)}$ values in Table 4
28-Oct-2013	3	<ul style="list-style-type: none"> – Modified: title, $R_{DS(on)}$ in cover page – Modified: $R_{DS(on)}$ typical and max values in Table 4, C_{iss} typical value in table 5 – Added: Q_{SS} in Table 5 – Modified: $t_{d(on)}$ and T_r typical values – Modified: T_{rr}, Q_{rr} and I_{RRM} typical values in Table 7 – Added: Section 2.1: Electrical characteristics (curves) – Updated: Section 4: Package mechanical data – Minor text changes

STL60N10F7

Please Read Carefully:

Information in this document is provided solely in connection with ST products. STMicroelectronics NV and its subsidiaries ("ST") reserve the right to make changes, corrections, modifications or improvements, to this document, and the products and services described herein at any time, without notice.

All ST products are sold pursuant to ST's terms and conditions of sale.

Purchasers are solely responsible for the choice, selection and use of the ST products and services described herein, and ST assumes no liability whatsoever relating to the choice, selection or use of the ST products and services described herein.

No license, express or implied, by estoppel or otherwise, to any intellectual property rights is granted under this document. If any part of this document refers to any third party products or services it shall not be deemed a license grant by ST for the use of such third party products or services, or any intellectual property contained therein or considered as a warranty covering the use in any manner whatsoever of such third party products or services or any intellectual property contained therein.

UNLESS OTHERWISE SET FORTH IN ST'S TERMS AND CONDITIONS OF SALE ST DISCLAIMS ANY EXPRESS OR IMPLIED WARRANTY WITH RESPECT TO THE USE AND/OR SALE OF ST PRODUCTS INCLUDING WITHOUT LIMITATION IMPLIED WARRANTIES OF MERCHANTABILITY, FITNESS FOR A PARTICULAR PURPOSE (AND THEIR EQUIVALENTS UNDER THE LAWS OF ANY JURISDICTION), OR INFRINGEMENT OF ANY PATENT, COPYRIGHT OR OTHER INTELLECTUAL PROPERTY RIGHT.

ST PRODUCTS ARE NOT DESIGNED OR AUTHORIZED FOR USE IN: (A) SAFETY CRITICAL APPLICATIONS SUCH AS LIFE SUPPORTING, ACTIVE IMPLANTED DEVICES OR SYSTEMS WITH PRODUCT FUNCTIONAL SAFETY REQUIREMENTS; (B) AERONAUTIC APPLICATIONS; (C) AUTOMOTIVE APPLICATIONS OR ENVIRONMENTS, AND/OR (D) AEROSPACE APPLICATIONS OR ENVIRONMENTS. WHERE ST PRODUCTS ARE NOT DESIGNED FOR SUCH USE, THE PURCHASER SHALL USE PRODUCTS AT PURCHASER'S SOLE RISK, EVEN IF ST HAS BEEN INFORMED IN WRITING OF SUCH USAGE, UNLESS A PRODUCT IS EXPRESSLY DESIGNATED BY ST AS BEING INTENDED FOR "AUTOMOTIVE, AUTOMOTIVE SAFETY OR MEDICAL" INDUSTRY DOMAINS ACCORDING TO ST PRODUCT DESIGN SPECIFICATIONS. PRODUCTS FORMALLY ESCC, QML OR JAN QUALIFIED ARE DEEMED SUITABLE FOR USE IN AEROSPACE BY THE CORRESPONDING GOVERNMENTAL AGENCY.

Resale of ST products with provisions different from the statements and/or technical features set forth in this document shall immediately void any warranty granted by ST for the ST product or service described herein and shall not create or extend in any manner whatsoever, any liability of ST.

ST and the ST logo are trademarks or registered trademarks of ST in various countries.

Information in this document supersedes and replaces all information previously supplied.

The ST logo is a registered trademark of STMicroelectronics. All other names are the property of their respective owners.

© 2013 STMicroelectronics - All rights reserved

STMicroelectronics group of companies

Australia - Belgium - Brazil - Canada - China - Czech Republic - Finland - France - Germany - Hong Kong - India - Israel - Italy - Japan - Malaysia - Malta - Morocco - Philippines - Singapore - Spain - Sweden - Switzerland - United Kingdom - United States of America

www.st.com