

Excellent Integrated System Limited

Stocking Distributor

Click to view price, real time Inventory, Delivery & Lifecycle Information:

[Finisar Corporation](#)
[FTLD10CE1C](#)

For any questions, you can email us directly:

sales@integrated-circuit.com

Finisar

Product Specification

100GBASE-SR10 100m CXP Optical Transceiver Module FTLD10CE1C

PRODUCT FEATURES

- 12-channel full-duplex transceiver module
- Hot Pluggable CXP form factor
- Maximum link length of 100m on OM3 Multimode Fiber (MMF)
- Multirate capability: 1.06Gb/s to 10.5Gb/s per channel
- Unretimed CPPI electrical interface
- Requires 3.3V power supply only
- Low power dissipation: < 3.5W
- Reliable VCSEL array technology
- Built-in digital diagnostic functions
- Commercial operating case temperature range: 0°C to 70°C
- Single MPO connector receptacle
- RoHS-6 Compliant (lead-free)



APPLICATIONS

- 100GBASE-SR10 100G Ethernet
- Multiple 4G/8G/10G Fibre Channel

Finisar’s FTLD10CE1C CXP transceiver modules are designed for use in up to 100 Gigabit per second links over multimode fiber. They are compliant with the CXP Specification¹ and IEEE 802.3ba 100GBASE-SR10 and CPPI interfaces². The transceiver is RoHS-6 compliant and lead-free per Directive 2002/95/EC³, and Finisar Application Note AN-2038⁴. For applications up to 12.5 Gb/s per channel please see Finisar part number FTLD12CL1C.

PRODUCT SELECTION

FTLD10CE1C

- 10: Up to 10.5 Gb/s per channel
- E: Ethernet-compliant optical interface
- 1: First generation product
- C: Commercial temperature rate

I. Pin Descriptions

Bottom side			Top Side		
I/O #	Name	Contact Length	Contact Length	Name	I/O #
Receiver -- Top Card					
C1	GND			GND	D1
C2	RX1p			RX0p	D2
C3	RX1n			RX0n	D3
C4	GND			GND	D4
C5	RX3p			RX2p	D5
C6	RX3n			RX2n	D6
C7	GND			GND	D7
C8	RX5p			RX4p	D8
C9	RX5n			RX4n	D9
C10	GND			GND	D10
C11	RX7p			RX6p	D11
C12	RX7n			RX6n	D12
C13	GND			GND	D13
C14	RX9p			RX8p	D14
C15	RX9n			RX8n	D15
C16	GND			GND	D16
C17	RX11p			RX10p	D17
C18	RX11n			RX10n	D18
C19	GND			GND	D19
C20	PRSNT_L			Vcc3.3-RX	D20
C21	Int_L/Reset_L			Vcc12-RX	D21
Transmitter -- Bottom Card					
A1	GND			GND	B1
A2	TX1p			TX0p	B2
A3	TX1n			TX0n	B3
A4	GND			GND	B4
A5	TX3p			TX2p	B5
A6	TX3n			TX2n	B6
A7	GND			GND	B7
A8	TX5p			TX4p	B8
A9	TX5n			TX4n	B9
A10	GND			GND	B10
A11	TX7p			TX6p	B11
A12	TX7n			TX6n	B12
A13	GND			GND	B13
A14	TX9p			TX8p	B14
A15	TX9n			TX8n	B15
A16	GND			GND	B16
A17	TX11p			TX10p	B17
A18	TX11n			TX10n	B18
A19	GND			GND	B19
A20	SCL			VCC3.3-TX	B20
A21	SDA			VCC12-TX	B21

Figure 1 – CXP-compliant 84-pin connector

Pin	Symbol	Name/Description	Notes
A1	GND	Ground	1
A2	Tx1p	Transmitter Non-Inverted Data Input	
A3	Tx1n	Transmitter Inverted Data Input	
A4	GND	Ground	1
A5	Tx3p	Transmitter Non-Inverted Data Input	
A6	Tx3n	Transmitter Inverted Data Input	
A7	GND	Ground	1
A8	Tx5p	Transmitter Non-Inverted Data Input	
A9	Tx5n	Transmitter Inverted Data Input	
A10	GND	Ground	1
A11	Tx7p	Transmitter Non-Inverted Data Input	
A12	Tx7n	Transmitter Inverted Data Input	
A13	GND	Ground	1
A14	Tx9p	Transmitter Non-Inverted Data Input	
A15	Tx9n	Transmitter Inverted Data Input	
A16	GND	Ground	1
A17	Tx11p	Transmitter Non-Inverted Data Input	
A18	Tx11n	Transmitter Inverted Data Input	
A19	GND	Ground	1
A20	SCL	2-wire serial interface clock	
A21	SDA	2-wire serial interface data	
B1	GND	Ground	1
B2	Tx0p	Transmitter Non-Inverted Data Input	
B3	Tx0n	Transmitter Inverted Data Input	
B4	GND	Ground	1
B5	Tx2p	Transmitter Non-Inverted Data Input	
B6	Tx2n	Transmitter Inverted Data Input	
B7	GND	Ground	1
B8	Tx4p	Transmitter Non-Inverted Data Input	
B9	Tx4n	Transmitter Inverted Data Input	
B10	GND	Ground	1
B11	Tx6p	Transmitter Non-Inverted Data Input	
B12	Tx6n	Transmitter Inverted Data Input	
B13	GND	Ground	1
B14	Tx8p	Transmitter Non-Inverted Data Input	
B15	Tx8n	Transmitter Inverted Data Input	
B16	GND	Ground	1
B17	Tx10p	Transmitter Non-Inverted Data Input	
B18	Tx10n	Transmitter Inverted Data Input	
B19	GND	Ground	1
B20	VCC3.3-TX	+3.3 V Power supply transmitter	
B21	VCC12-TX	+12.0 V Power supply transmitter - NOT CONNECTED	2
C1	GND	Ground	1
C2	Rx1p	Receiver Non-Inverted Data Output	
C3	Rx1n	Receiver Inverted Data Output	
C4	GND	Ground	1
C5	Rx3p	Receiver Non-Inverted Data Output	
C6	Rx3n	Receiver Inverted Data Output	
C7	GND	Ground	1
C8	Rx5p	Receiver Non-Inverted Data Output	
C9	Rx5n	Receiver Inverted Data Output	
C10	GND	Ground	1

C11	Rx7p	Receiver Non-Inverted Data Output	
C12	Rx7n	Receiver Inverted Data Output	
C13	GND	Ground	1
C14	Rx9p	Receiver Non-Inverted Data Output	
C15	Rx9n	Receiver Inverted Data Output	
C16	GND	Ground	1
C17	Rx11p	Receiver Non-Inverted Data Output	
C18	Rx11n	Receiver Inverted Data Output	
C19	GND	Ground	1
C20	PRSNT L	Module Present	
C21	Int L/Reset L	Interrupt / Reset	
D1	GND	Ground	1
D2	Rx0p	Receiver Non-Inverted Data Output	
D3	Rx0n	Receiver Inverted Data Output	
D4	GND	Ground	1
D5	Rx2p	Receiver Non-Inverted Data Output	
D6	Rx2n	Receiver Inverted Data Output	
D7	GND	Ground	1
D8	Rx4p	Receiver Non-Inverted Data Output	
D9	Rx4n	Receiver Inverted Data Output	
D10	GND	Ground	1
D11	Rx6p	Receiver Non-Inverted Data Output	
D12	Rx6n	Receiver Inverted Data Output	
D13	GND	Ground	1
D14	Rx8p	Receiver Non-Inverted Data Output	
D15	Rx8n	Receiver Inverted Data Output	
D16	GND	Ground	1
D17	Rx10p	Receiver Non-Inverted Data Output	
D18	Rx10n	Receiver Inverted Data Output	
D19	GND	Ground	1
D20	Vcc3.3-RX	+3.3 V Power supply receiver	
D21	Vcc12-RX	+12.0 V Power supply receiver - NOT CONNECTED	2

Notes

1. Circuit ground is internally isolated from chassis ground.
2. 12V power supply not required.

II. General Product Characteristics

Parameter	Value	Unit	Notes
Module Form Factor	CXP		
Number of Lanes	12 Tx and 12 Rx		
Maximum Aggregate Data Rate	126	Gb/s	
Maximum Data Rate per Lane	10.5	Gb/s	
Protocols Supported	Typical applications include 100G Ethernet, Infiniband, Fibre Channel, SATA/SAS3		
Electrical Interface and Pin-out	84-pin edge connector		Pin-out as defined by the CXP Specification
Optical Cable Type Required	Multimode ribbon 24-fiber cable assembly, MPO connector		
Maximum Power Consumption per End	3.5	Watts	Varies with output voltage swing and pre-emphasis settings (see Figure 2)
Management Interface	Serial, I2C-based, 450 kHz maximum frequency		As defined by the CXP Specification

Data Rate Specifications	Symbol	Min	Typ	Max	Units	Ref.
Bit Rate per Lane	BR	1000		10500	Mb/sec	1
Bit Error Ratio	BER			10 ⁻¹²		2
Link distance on OM3 MMF	d			100	meters	3

Notes:

1. Infiniband SDR/DDR/QDR, 1/10/40/100 Gigabit Ethernet, 1/2/4/8/10G Fibre Channel.
2. Tested with a PRBS 2³¹-1 test pattern.
3. Per 100GBASE-SR10 PMD maximum link distance in IEEE 802.3.ba.

III. Absolute Maximum Ratings

Parameter	Symbol	Min	Typ	Max	Unit	Ref.
Maximum Supply Voltage	Vcc1, VccTx, VccRx	-0.5		3.6	V	
Storage Temperature	T _S	-40		85	°C	
Case Operating Temperature	T _{OP}	0		70	°C	
Relative Humidity	RH	0		85	%	1

Notes:

1. Non-condensing.

IV. Electrical Characteristics ($T_{OP} = 0$ to $70^{\circ}C$, $V_{CC} = 3.3 \pm 5\%$ Volts)

NOTE: The FTLD10CE1C requires that a CPPI-compliant CXP electrical connector be used on the host board in order to guarantee its electrical interface specification. Please check with your connector supplier.

Parameter	Symbol	Min	Typ	Max	Unit	Ref.
Supply Voltage	Vcc1, VccTx, VccRx	3.15		3.45	V	
Supply Current	Icc		850	1000	mA	
Module Total Power	P			3.5	W	1
Link Turn-On Time						
Transmit turn-on time				2000	ms	2
Transmitter (per Lane)						
Single ended input voltage tolerance	VinT	-0.3		4.0	V	
Differential data input swing	Vin,pp	120		1200	mVpp	3
Differential input threshold			50		mV	
AC common mode input voltage tolerance (RMS)		15			mV	
Differential input return loss			Per IEEE 802.3ba, Section 86A.4.1.1		dB	4
J2 Jitter Tolerance	Jt2	0.17			UI	
J9 Jitter Tolerance	Jt9	0.29			UI	
Data Dependent Pulse Width Shrinkage	DDPWS	0.07			UI	
Eye mask coordinates {X1, X2 Y1, Y2}			0.11, 0.31 95, 350		UI mV	5
Receiver (per Lane)						
Single-ended output voltage		-0.3		4.0	V	
Differential data output swing	Vout,pp	0		800	mVpp	6,7
AC common mode output voltage (RMS)				7.5	mV	
Termination mismatch at 1 MHz				5	%	
Differential output return loss			Per IEEE 802.3ba, Section 86A.4.2.1		dB	4
Common mode output return loss			Per IEEE 802.3ba, Section 86A.4.2.2		dB	4
Output transition time, 20% to 80%		28			ps	
J2 Jitter output	Jo2			0.42	UI	
J9 Jitter output	Jo9			0.65	UI	
Eye mask coordinates {X1, X2 Y1, Y2}			0.29, 0.5 150, 425		UI mV	5
Power Supply Ripple Tolerance	PSR	50			mVpp	

Notes:

1. Maximum total power value is specified across the full temperature and voltage range.
2. From power-on and end of any fault conditions.
3. After internal AC coupling. Self-biasing 100Ω differential input.
4. 10 MHz to 11.1 GHz range
5. Hit ratio = $5 \times 10E-5$
6. AC coupled with 100Ω differential output impedance.
7. Settable in 4 discrete steps via the I2C interface. See Figure 2 for Vout settings.

		Pre-Emphasis into 100ohms (mV)			
		0	125	175	325
Vo (mV)	0	1189			
	317	1645	2197	2305	2617
	422	1753	2305	2413	2725
	739	2041	2557	2701	2962

Figure 2 – Power Dissipation (mW, typical) vs. Rx Output Conditions

V. Optical Characteristics (T_{OP} = 0 to 70°C, V_{CC} = 3.3 ± 5% Volts)

Parameter	Symbol	Min	Typ	Max	Unit	Ref.
Transmitter (per Lane)						
Signaling Speed per Lane			10.5		GBd	1
Center wavelength		840		860	nm	
RMS Spectral Width	SW			0.65	nm	
Average Launch Power per Lane	TXP _x	-7.6		2.4	dBm	
Transmit OMA per Lane	TxOMA	-5.6		3.0	dBm	2
Difference in Power between any two lanes [OMA]	DP _x			4.0	dB	
Peak Power per Lane	PP _x			4.0	dBm	
Launch Power [OMA] minus TDP per Lane	P-TDP	-6.5			dBm	
TDP per Lane	TDP			3.5	dBm	
Optical Extinction Ratio	ER	3.0			dB	
Optical Return Loss Tolerance	ORL			12	dB	
Encircled Flux	FLX		> 86% at 19 um < 30% at 4.5 um		dBm	
Average launch power of OFF transmitter, per lane				-30	dBm	
Relative Intensity Noise	RIN			-128	dB/Hz	3
Transmitter eye mask definition {X1, X2, X3, Y1, Y2, Y3}		0.23, 0.34, 0.43, 0.27, 0.35, 0.4				
Receiver (per Lane)						
Signaling Speed per Lane			10.5		GBd	4
Center wavelength		840		860	nm	
Damage Threshold	DT	3.4			dBm	
Average Receive Power per Lane	RXP _x	-9.5		2.4	dBm	
Receive Power (OMA) per Lane	RxOMA			3.0	dBm	
Stressed Receiver Sensitivity (OMA) per Lane	SRS			-5.4	dBm	
Peak Power, per lane	PP _x			4	dBm	
Receiver Reflectance	Rfl			-12	dB	
Vertical eye closure penalty, per lane				1.9	dB	
Stressed eye J2 jitter, per Lane				0.3	UI	
Stressed eye J9 jitter, per Lane				0.47	UI	
OMA of each aggressor lane				-0.4	dBm	
Receiver jitter tolerance [OMA], per Lane				-5.4	dBm	
Rx jitter tolerance: Jitter frequency		(75, 5)			kHz, UI	

and p-p amplitude		(375, 1)			kHz, UI	
LOS De-Assert	LOS _D			-11	dBm	
LOS Assert	LOS _A			-14	dBm	
LOS Hysteresis		1			dB	

Notes:

1. Transmitter consists of 12 lasers operating at a maximum rate of 10.5Gb/s each.
2. Even if TDP is <0.9dB, the OMA min must exceed this value.
3. RIN is scaled by 10*log (10/4) to maintain SNR outside of transmitter.
4. Receiver consists of 12 photodetectors operating at a maximum rate of 10.5Gb/s each.

VI. Memory Map and Control Registers

Compatible with the CXP Specification. Please see Finisar Application Note AN-2085 for a detailed description.

VII. Environmental Specifications

Finisar FTLD10C transceiver modules have an operating temperature range from 0°C to +70°C case temperature.

Environmental Specifications	Symbol	Min	Typ	Max	Units	Ref.
Case Operating Temperature	T _{op}	0		70	°C	
Storage Temperature	T _{sto}	-40		85	°C	

VIII. Regulatory Compliance

Finisar FTLD10C transceiver modules are RoHS-6 Compliant and Class 1 laser eye safety compliant per IEC 60825-1. Copies of certificates are available at Finisar Corporation upon request.

IX. Mechanical Specifications

The FTLD10C transceiver module mechanical specifications are based on the CXP Specification.

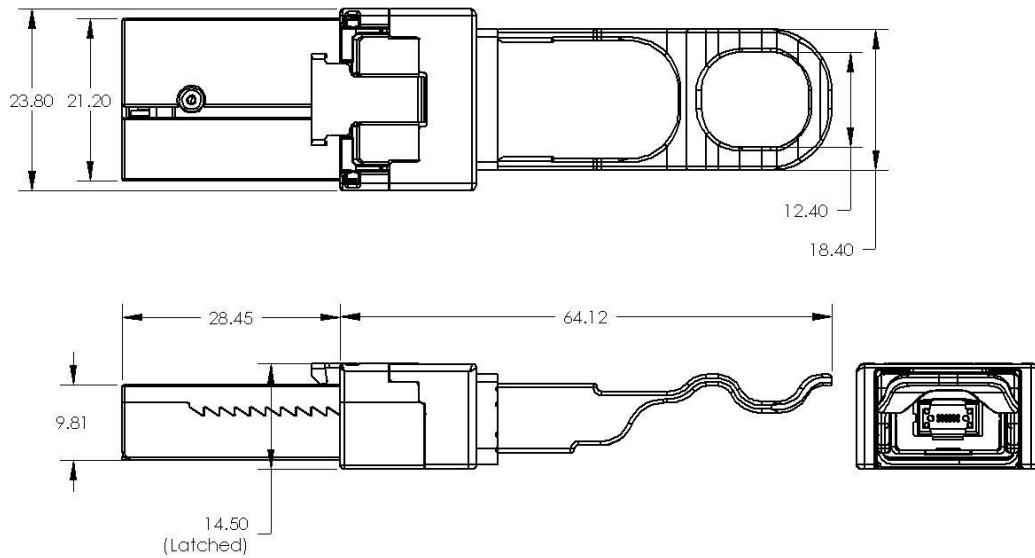

Figure 5 – FTLD10C mechanical drawing

X. References

1. Supplement to Infiniband Architecture Specification, Volume 2, Release 1.2.1., Annex A6: "120 Gb/s 12x Small Form-factor Pluggable (CXP) - Interface Specification for Cables, Active Cables, & Transceivers", September 2009
2. IEEE 802.3ba, PMD Type 100GBASE-SR10
3. Directive 2002/95/EC of the European Council Parliament and of the Council, “on the restriction of the use of certain hazardous substances in electrical and electronic equipment”. January 27, 2003.
4. “Application Note AN-2038: Finisar Implementation Of RoHS Compliant Transceivers”, Finisar Corporation.
5. “Application Note AN-2085: CXP Transceiver EEPROM Mapping”, Finisar Corporation.

XI. For More Information

Finisar Corporation
1389 Moffett Park Drive
Sunnyvale, CA 94089-1133
Tel. 1-408-548-1000
Fax 1-408-541-6138
sales@finisar.com
www.finisar.com