

Excellent Integrated System Limited

Stocking Distributor

Click to view price, real time Inventory, Delivery & Lifecycle Information:

[BUD Industries, Inc.](#)

[PN-1337](#)

For any questions, you can email us directly:

sales@integrated-circuit.com

PART NAME	NEMA 4X ENCLOSURE	PART No.	PN-1337, PN-1337-C AND PN-1337-DG	REV. DATE	11-17-08
-----------	-------------------	----------	-----------------------------------	-----------	----------

INDUSTRY STANDARDS:

POLYCARBONATE (LIGHT GRAY AND CLEAR)
 UL94-HB FLAMMABILITY RATING (UL FILE #E41613)
 UV STABILIZED
 SERVICE TEMPERATURE RANGE: -40°C TO +120°C
 ABS (DARK GRAY)
 UL94-HB FLAMMABILITY RATING (UL FILE #E56070)
 SERVICE TEMPERATURE RANGE: -40°C TO +80°C

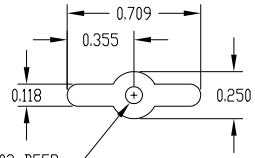
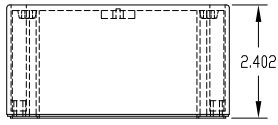

0.090 DIA. HOLE x 0.203 DEEP
 MOUNTING BOSSES USE EITHER
 M2.5 METRIC OR #4 STD. SHEET
 METAL SCREWS x 0.188 LG.
 (NOT SUPPLIED)

DETAIL "C"
(4) PLACES

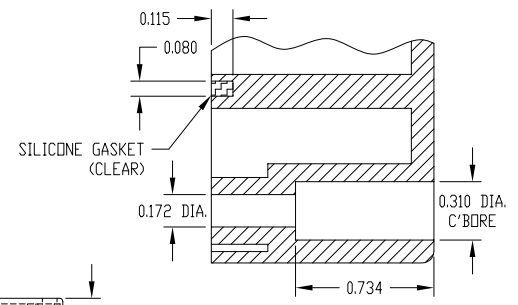

DETAIL "D"

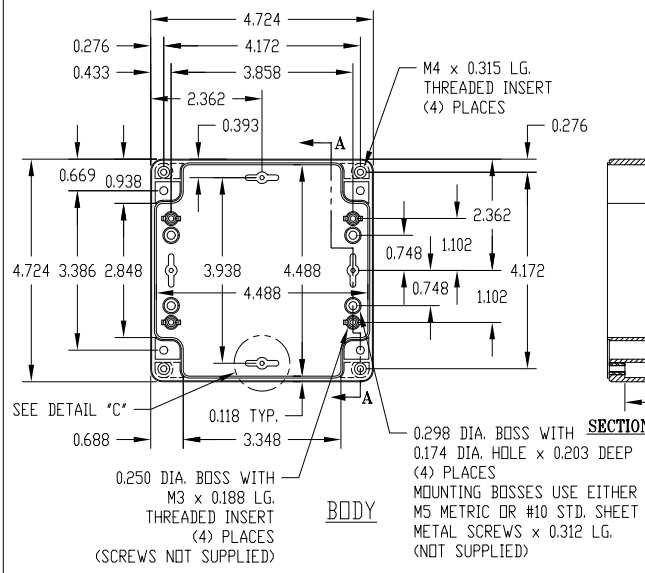

BODY

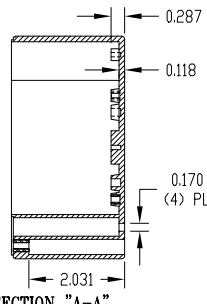

SECTION "A-A"

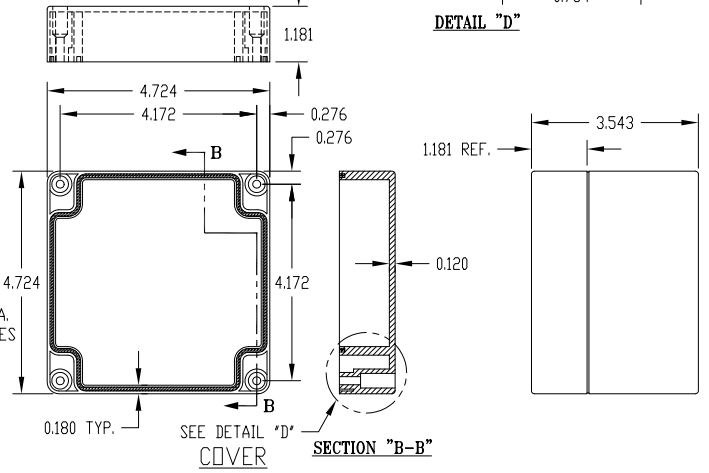

COVER

SECTION "B-B"

NOTE: ALL DIMENSIONS HAVE ±0.015 TOLERANCE UNLESS OTHERWISE SPECIFIED.

PART NUMBER	MATERIAL		FINISH		HARDWARE KIT
	BODY	COVER	BODY	COVER	
PN-1337	POLYCARBONATE	POLYCARBONATE	LIGHT GRAY	CLEAR	KIT CONTAINS (4) M4 x 20mm (0.787") LG. SCREWS FOR ASSEMBLY
PN-1337-C	POLYCARBONATE	POLYCARBONATE	LIGHT GRAY	CLEAR	
PN-1337-DG	HIGH-IMPACT ABS	HIGH-IMPACT ABS	DARK GRAY	CLEAR	