

Excellent Integrated System Limited

Stocking Distributor

Click to view price, real time Inventory, Delivery & Lifecycle Information:

[Panasonic Electronic Components](#)
[LNJ411K84RA](#)

For any questions, you can email us directly:

sales@integrated-circuit.com

Approved	Checked	Designed	DEVELOPMENT SPECIFICATION	P/N: LNJ411K84RA	TEMPORARY
<i>T. Shoda</i>	<i>M. W.</i>	<i>T. Takata</i>			

T Y P E	Amber Light Emitting Diode					
APPLICATION	Indicators					
MATERIAL	InGaAlP					
OUTLINE	Attached					
ABSOLUTE MAXIMUM RATINGS	P	*I _{FP}	I _{FDC}	V _R	Topr	Tstg
	55	60	20	4	-30~+85	-40~+100
	mW	mA	mA	V	°C	°C
CONDITION	Ta=25±3°C					

Test Specification

Item	Symbol	Condition	Typ	Limit		Unit
				Min	Max	
Forward Voltage	V _F	I _F =10mA	2.0		2.5	V
Reverse Leakage Current	I _R	V _R = 4V			100	μA
Luminous Intensity	I _O	I _F =10mA DC	17	9.0		mcd
Peak Emission Wavelength	λ _p	I _F =10mA DC	595			nm
Spectral Line Half Width	Δλ	I _F =10mA DC	15			nm

- *1. The Condition of I_{FP} is duty 10%. Pulse width 1ms
- *2. Tolerance of luminous intensity: ±20%.

NOTE

- ★1. Please contact the Panasonic local office if you design at low current (below 1mA DC) or pulse current operation and have any questions.
- ★2. Soldering conditions... Refer to Handling note.
- ★3. Compositions of the lead... Cu/Ni/Au plating
- ★4. Beware of destruction by static electricity in handling the LED.
- ★5. Circuit to operate LED.

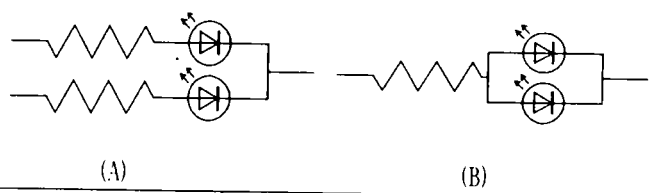

(A) Recommended circuit.
 (B) The difference of brightness between the LED could be found due to the V_F characteristics of each LED.

Jul. 25. 2001			

Approved <i>T. Akeda</i>	Checked <i>M. H.</i>	Designed <i>T. Tabata</i>
-----------------------------	-------------------------	------------------------------

DEVELOPMENT SPECIFICATION

P/N: LNJ411K84RA

TEMPORARY

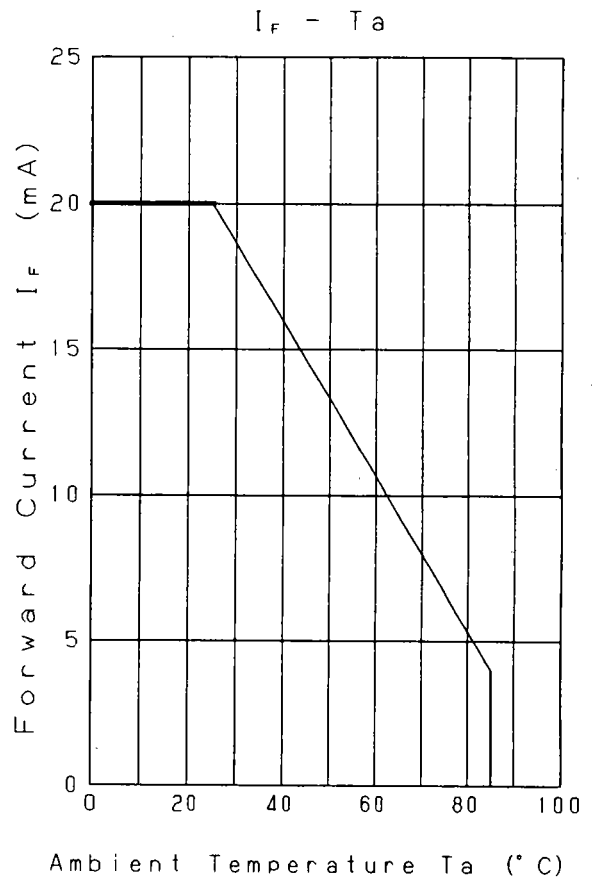
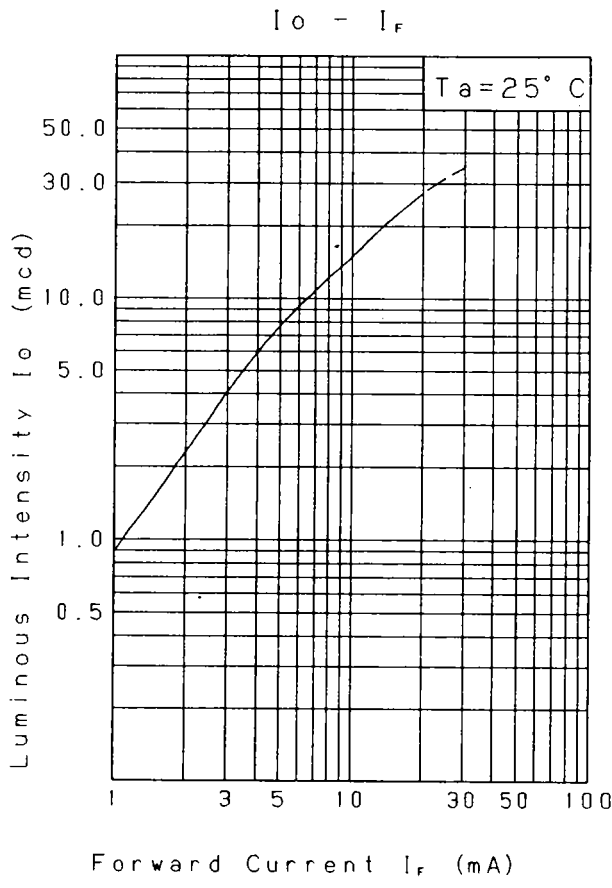
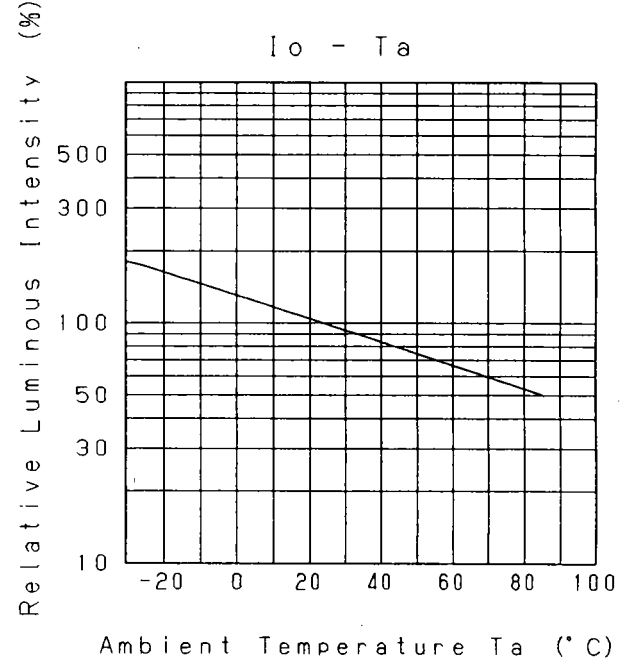
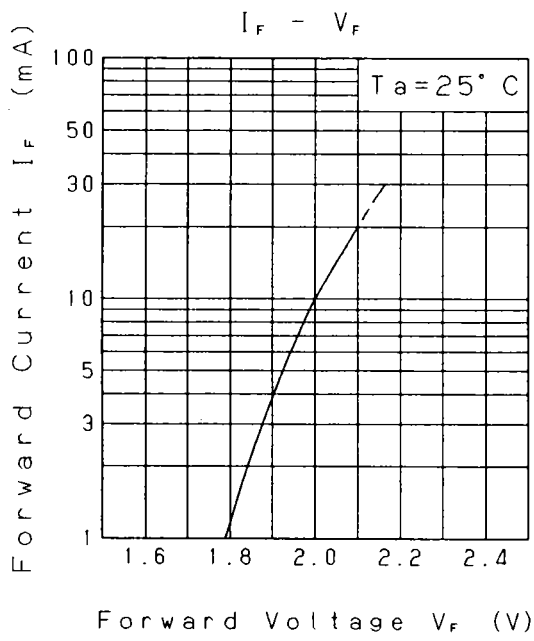

Jul. 25. 2001

Approved	Checked	Designed
<i>T. Shikata</i>	<i>M. Ito</i>	<i>T. Tabata</i>

DEVELOPMENT SPECIFICATION

P/N: LNJ411K84RA

TEMPORARY

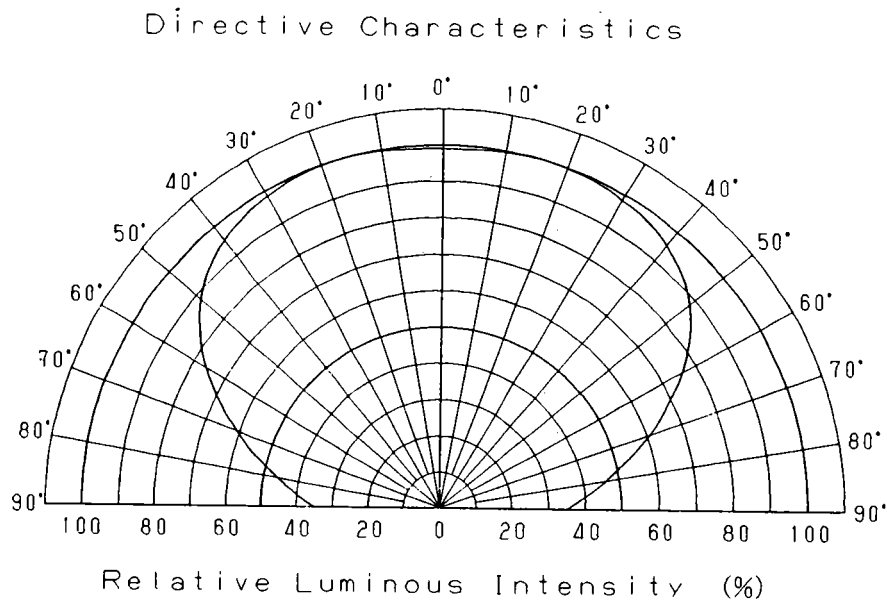
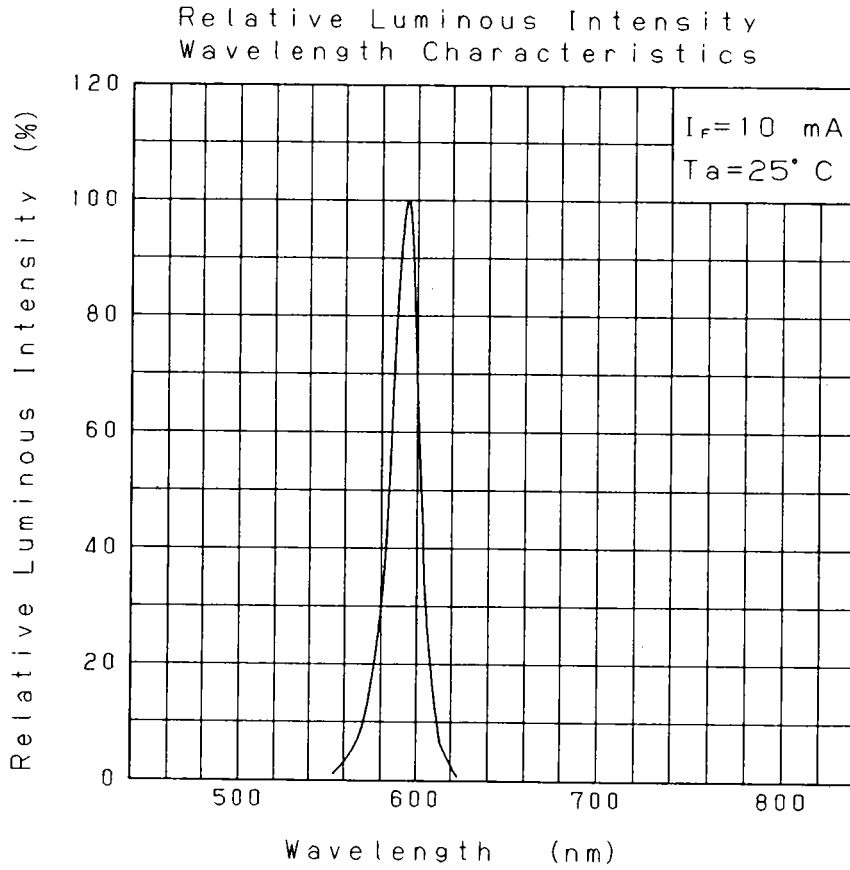

Apr.20.2001

Approved	Checked	Designed	DEVELOPMENT SPECIFICATION (OUTLINE)		
<i>T. Shioda</i>	<i>M. Ichi</i>	<i>T. Takata</i>		P/N: LNJ411K84RA	

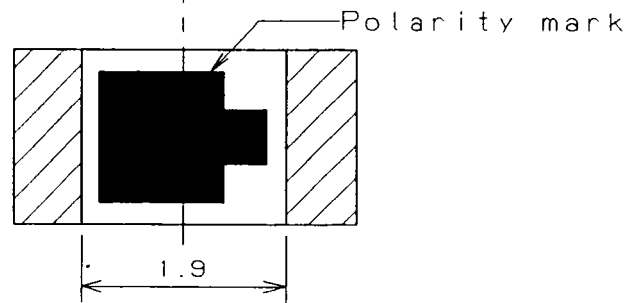
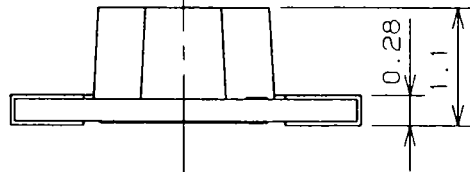
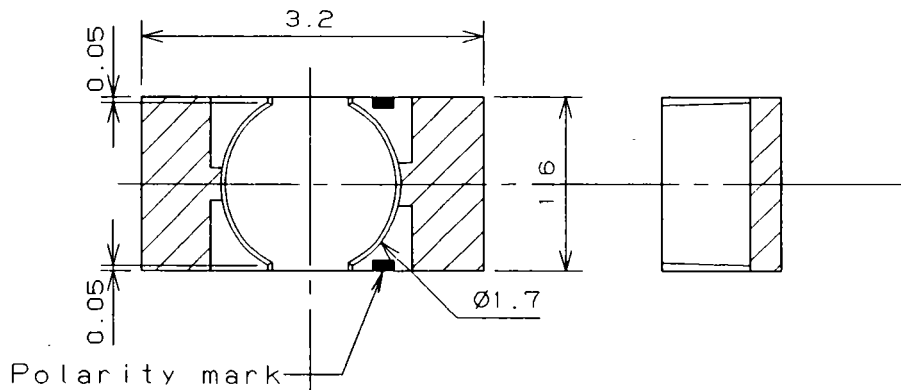

Recommended Land Layout

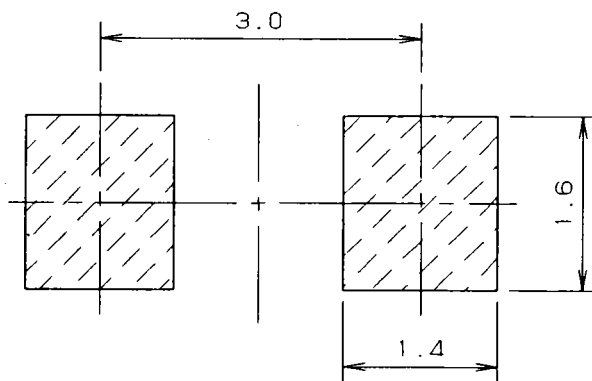

Polarity

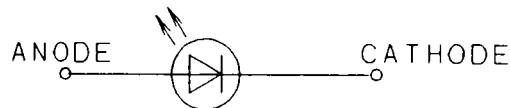

(NOTE)

1. Unit: mm
2. Tolerance unless specified is ± 0.15 .
3. indicate Au terminal.

Jul. 25. 2001			