

## Excellent Integrated System Limited

Stocking Distributor

Click to view price, real time Inventory, Delivery & Lifecycle Information:

[ebm-papst Inc.](#)  
[4412FGML](#)

For any questions, you can email us directly:

[sales@integrated-circuit.com](mailto:sales@integrated-circuit.com)

4412 FGML

## DC axial compact fan



**ebm-papst St. Georgen GmbH & Co. KG**

Hermann-Papst-Straße 1

D-78112 St. Georgen

Phone +49 7724 81-0

Fax +49 7724 81-1309

info2@de.ebmpapst.com

www.ebmpapst.com

### Nominal data

Type	4412 FGML	
Nominal voltage	VDC	12
Nominal voltage range	VDC	7 .. 12.6
Speed	min <sup>-1</sup>	1950
Power input	W	2.0
Min. ambient temperature	°C	-20
Max. ambient temperature	°C	75
Air flow	m <sup>3</sup> /h	114
Sound power level	B	4.3
Sound pressure level	dB(A)	32

ml = max. load · me = max. efficiency · rfa = running at free air · cs = customer specs · cu = customer unit  
 Subject to alterations

4412 FGML

## DC axial compact fan

### Technical features

<b>Dimensions</b>	119 x 119 x 25 mm
<b>General description</b>	<p>Particular design features:</p> <ul style="list-style-type: none"> <li>Ball bearings and sleeve bearings available.</li> <li>Open loop speed control on request.</li> <li>Tachometer and alarm on request.</li> </ul> <p>General features:</p> <ul style="list-style-type: none"> <li>Material: fibreglass-reinforced plastic. Impeller PA, housing PBT.</li> <li>Electronic commutation completely integrated.</li> <li>Protected against reverse polarity and locking.</li> <li>Connection via single strands AWG 24, TR 64, bared and tin-plated.</li> <li>Air exhaust over bars. Direction of rotation counter-clockwise seen on rotor.</li> <li>Mass: 175 g.</li> </ul>
<b>Connection line</b>	Single strands AWG 24, TR 64, bared and tin-plated.
<b>Locked-rotor protection</b>	Blocking and overload protection
<b>Direction of rotation</b>	Left, looking at rotor
<b>Direction of air flow</b>	Air exhaust over bars
<b>Bearing</b>	Sintec sleeve bearing
<b>Lifetime L10 at 40 °C</b>	75000 h
<b>Lifetime L10 at maximum temperature</b>	32500 h
<b>Mass</b>	0.175 kg
<b>Housing material</b>	Fiberglass-reinforced PBT plastic
<b>Material of impeller</b>	Fiberglass-reinforced PA plastic
<b>Motor protection</b>	Protected against reverse polarity and locking.
<b>Approval</b>	VDE, CSA, UL, CE

4412 FGML

DC axial compact fan

Product drawing

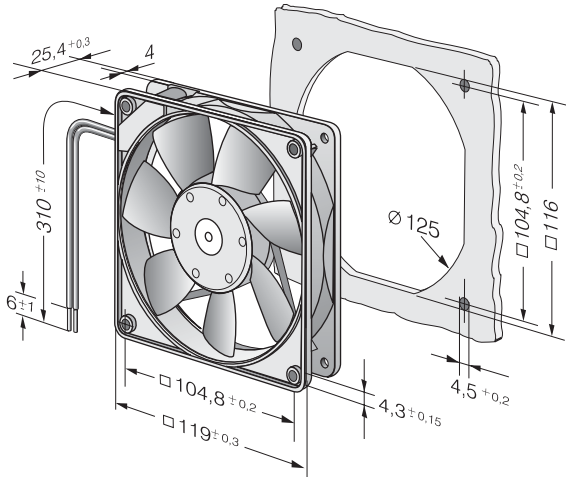

4412 FGML

DC axial compact fan

Charts: Air flow

