

## Excellent Integrated System Limited

Stocking Distributor

Click to view price, real time Inventory, Delivery & Lifecycle Information:

[Finisar Corporation](#)

[FTGL2025S1TUS](#)

For any questions, you can email us directly:

[sales@integrated-circuit.com](mailto:sales@integrated-circuit.com)

# Finisar

## Preliminary Product Specification

### GPON OLT Class B+ Pigtailed RoHS Compliant Transceiver

#### FTGL2025S1TUx

#### PRODUCT FEATURES

- Bi-directional transceivers operating at 2.488 Gbit/s downstream, 1.244 Gbit/s upstream
- Di-plexer operation at 1490 nm Tx, and 1310 nm digital Rx
- Burst-mode APD receiver
- Continuous mode transmitter with DFB laser
- Built-in digital diagnostic functions
- Standard small form-factor (SFF) package with fiber pigtailed SC/UPC connector in compliant with GR326 and UL 94V0 flammability
- The pigtail comes in a tight buffer 0.9mm, 9/125/250 SMF-28 or equivalent
- Single 3.3V power supply
- Industrial operating temperature range: -40°C to 85°C

- Built-in digital diagnostic functions



#### APPLICATIONS

- GPON OLT Di-plexer
- ITU-T G.984.2 Class B+

Finisar's FTGL2025FDIUx bi-directional transceivers comply with the ITU-T GPON standard<sup>1</sup> G984.2 Class B+ for operation at 2.488 Gbit/s downstream and 1.244 Gbit/s upstream. The di-plexer function provides burst-mode APD receiver at 1310nm, and continuous DFB transmitter at 1490 nm. Digital diagnostics functions are available via the 2-wire serial bus specified in the SFP MSA<sup>1</sup>. Details to the EEPROM map for this module could be made available upon request. Finisar's FTGL2025FDIUx SFF transceivers are compatible with the Small Form Factor Multi-Sourcing Agreement (MSA)<sup>2</sup>.

#### PRODUCT SELECTION

#### FTGL2025S1TUx

x	S	Standard Pigtail length
---	---	-------------------------

### I. Pin Descriptions

Pin	Symbol	Description/Comments	Interface
1	B-M Reset	B-M RX Reset	Input/LVTTL; Active high and control by the host
2	Reserved	Reserved (no connect)	Reserved for future application
3	RX GND	Receiver Ground.	
4	Reserved	Reserved (no connect)	Reserved for future application
5	Rx Vcc	Receive Vcc	
6	RX GND	MSA 2x5 standard	
7	RX Vcc	MSA 2x5 standard	
8	RX SD	MSA 2x5 standard	Output/LVTTL; Active high
9	RX D-	MSA 2x5 standard	Output/LVPECL; DC coupled termination needed on the host
10	RX D+	MSA 2x5 standard	Output/LVPECL; DC coupled termination needed on the host
11	TX Vcc	MSA 2x5 standard	
12	TX GND	MSA 2x5 standard	
13	TX Dis	MSA 2x5 standard	Input/LVTTL; Active high and control by the host
14	TX D+	MSA 2x5 standard	Input/CML AC coupled with internal 100Ohms termination
15	TX D-	MSA 2x5 standard	Input/CML AC coupled with internal 100Ohms termination
16	TX GND	Transmitter Ground	
17	SCL	Serial clock interface	Input; Recommend a tri-state buffer with 10K pull up on the host
18	SDA	Serial data interface	I/O; Open drain. Recommend 1K pull up on the host
19	TX Fail	Laser safety shut down	Output/LVTTL open drain with internal pull up
20	TX GND	TX Ground	

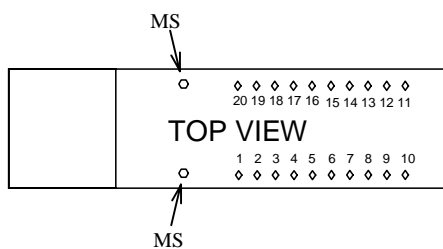

**SFF Pinout Top View (SFF MSA dimension but with bi-directional pigtail)**

## II. Absolute Maximum Ratings

Parameter	Symbol	Min	Typ	Max	Unit	Ref.
Maximum Supply Voltage	V <sub>CC</sub>	0		4.3	V	
Storage Temperature	T <sub>S</sub>	-40		85	°C	
Case Operating Temperature	T <sub>OP</sub>	-40		85	°C	
Relative Humidity	RH	0		95	%	1
Fiber Output Power (no damage)	P <sub>f</sub>			20	dBm	
Optical Input Power (no damage)	P <sub>IN</sub>			5	dBm	

## III. Electrical Characteristics (T<sub>OP</sub> = -40 to 85 °C, V<sub>CC</sub> = 3.1 to 3.5 Volts)

Parameter	Symbol	Min	Typ	Max	Unit	Ref.
Supply Voltage	V <sub>CC</sub>	3.00	3.3	3.60	V	
Supply Current	I <sub>CC</sub>			450	mA	
<b>Transmitter</b>						
Input Differential Impedance	R <sub>in</sub>		100		Ω	
Differential Data Input Voltage	V <sub>in,pp</sub>	500		1600	mV	
Transmit Disable Voltage	V <sub>D</sub>	2.0		V <sub>CC</sub>	V	
Transmit Enable Voltage	V <sub>EN</sub>	0		0.8	V	
Transmit Disable Assert Time				10	μs	
<b>Receiver</b>						
Output Differential Impedance			100		Ω	
Differential Data Output Voltage	V <sub>out,pp</sub> , LVPECL	500		1800	mV	
Data Output Rise and Fall Time	t <sub>r</sub> , t <sub>f</sub>			350	ps	2
SD Fault	V <sub>SD fault</sub>	0		0.5	V	
SD Normal	V <sub>LOS norm</sub>	2.4		V <sub>CC</sub>	V	
Power Supply Rejection	PSR	100			mVpp	3

### Notes:

1. Non condensing.
2. 20 – 80 %
3. 0.01 to 10 MHz

**IV. Optical Characteristics (T<sub>OP</sub> = -40 to 85 °C, V<sub>CC</sub> = 3.00 to 3.60 Volts)**

Parameter	Symbol	Min	Typ	Max	Unit	Ref.
Cross-talk 1490nm Tx to 1310nm Rx				-47	dB	
Reflectance 1480-1550 nm				-20	dB	
Reflectance 1260-1360 nm				-20	dB	
<b>Transmitter</b>						
Data Rate (Continuous Wave)	BR		2488.32		Mb/s	
Center Wavelength (CW)	$\lambda$	1480	1490	1500	nm	
Spectral Width (-20dB)	$\sigma$			1.0	nm	
Side Mode Suppr. Ratio	SSR	30			dB	
Output Opt. Pwr	P <sub>OUT</sub>	1.5		+5	dBm	1
Optical Extinction Ratio	ER	10			dB	
CID		72			bits	
Generated Jitter (Additive)	J <sub>add</sub>			.20	UI	2
Tx Power D.D. Accuracy				±3	dB	
<b>Receiver</b>						
Data Rate	BR		1244.16		Mb/s	
Optical Center Wavelength	$\lambda_C$	1260	1310	1360	nm	
Average Rx Sensitivity	R <sub>SENS1</sub>			-28	dBm	3
Overload		-8			dBm	
Dynamic Range		15			dB	4
CID		72			bits	
SD Assert	SD <sub>A</sub>			-31.5	dBm	
SD De-Assert	SD <sub>D</sub>	-45.0			dBm	
SD Hysteresis		0.5			dB	
SD Assert/De-Assert Time	SD <sub>T</sub>			1000	ns	

Notes:

1. Class 1 Laser Safety per FDA/CDRH and EN (IEC) 60825 regulations.
2. Jitter measurements taken using Agilent OMNIBERT 718 in accordance with GR-253.
3. With worst-case extinction ratio. Measured with a PRBS 2<sup>23</sup>-1 test, 10<sup>-10</sup> BER.
4. The receiver operates in burst mode at 1244 Mbs with up to 15dB difference between High and Low Level for adjacent ONT Cells.

### V. Reset Timing Requirement

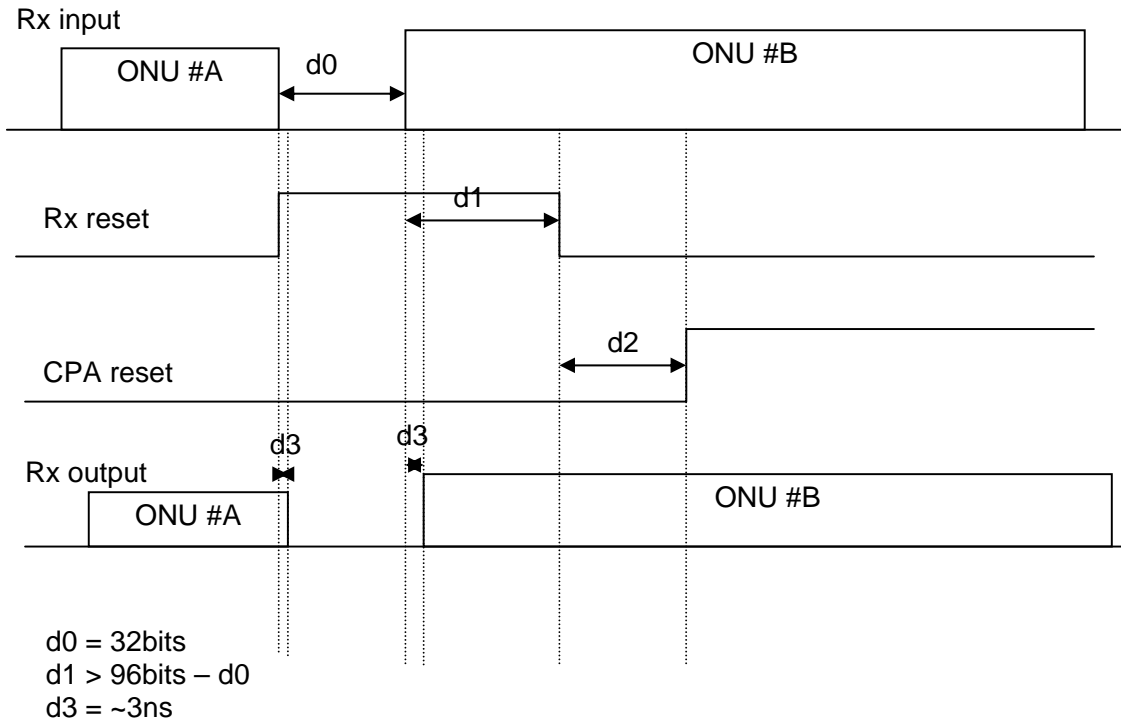

### VI Fiber Pigtail Specifications

Parameter	Symbol	Min	Typ	Max	Units	Ref.
Fiber Type			SMF-28E			
Jacket - Tight Buffer			900		$\mu\text{m}$	
Pigtail Length		950	1000	1050	mm	
Connector Type			SC/UPC			
Bending Radius of fiber		25			mm	
Tensile Force on Pigtail				2	N	

Notes:

### VII Environmental Specifications

Industrial operating temperature range:

Parameter	Symbol	Min	Typ	Max	Units	Ref.
Case Operating Temperature	$T_{op}$	-40		85	$^{\circ}\text{C}$	
Storage Temperature	$T_{sto}$	-40		100	$^{\circ}\text{C}$	

## **VIII Regulatory Compliance**

Finisar transceivers are Class 1 Laser Products and comply with US FDA regulations. These products are certified by TÜV and CSA to meet the Class 1 eye safety requirements of EN (IEC) 60825 and the electrical safety requirements of EN (IEC) 60950. Copies of certificates are available at Finisar Corporation upon request.

## **IX Digital Diagnostic Functions**

Finisar FTGL2025S1TUx transceivers support the 2-wire serial communication protocol as defined in the SFP MSA<sup>1</sup>.

The standard SFP serial ID provides access to identification information that describes the transceiver's capabilities, standard interfaces, manufacturer, and other information.

Additionally, Finisar transceivers provide a unique enhanced digital diagnostic monitoring interface, which allows real-time access to device operating parameters such as transceiver temperature, laser bias current, transmitted optical power, received optical power and transceiver supply voltage. It also defines a sophisticated system of alarm and warning flags, which alerts end-users when particular operating parameters are outside of a factory-set normal range.

The SFP MSA defines a 256-byte memory map in E<sup>2</sup>PROM that is accessible over a 2-wire serial interface at the 8 bit address 1010000X (A0h). The digital diagnostic monitoring interface makes use of the 8 bit address 1010001X (A2h), so the originally defined serial ID memory map remains unchanged. The complete interface is described in Finisar Application Note AN-2030: "Digital Diagnostics Monitoring Interface for SFP Optical Transceivers".

The operating and diagnostics information is monitored and reported by a Digital Diagnostics Transceiver Controller (DDTC) inside the transceiver, which is accessed through a 2-wire serial interface. When the serial protocol is activated, the serial clock signal (SCL) is generated by the host. The positive edge clocks data into the SFP transceiver into those segments of the E<sup>2</sup>PROM that are not write-protected. The negative edge clocks data from the SFP transceiver. The serial data signal (SDA) is bi-directional for serial data transfer. The host uses SDA in conjunction with SCL to mark the start and end of serial protocol activation. The memories are organized as a series of 8-bit data words that can be addressed individually or sequentially.

For more information, please contact Finisar.

Digital diagnostics for the FTGL2025S1TUx are internally calibrated by default.



**X. Recommended Host Board Supply Filtering Network**

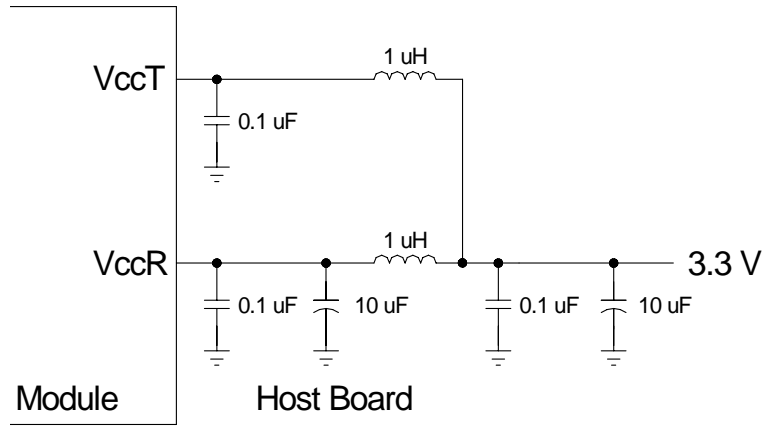

**XI. Mechanical Specifications**

Finisar's Small Form Factor (SFF) transceivers are compatible with the dimensions defined by the SFF Multi-Sourcing Agreement (MSA)<sup>3</sup>.

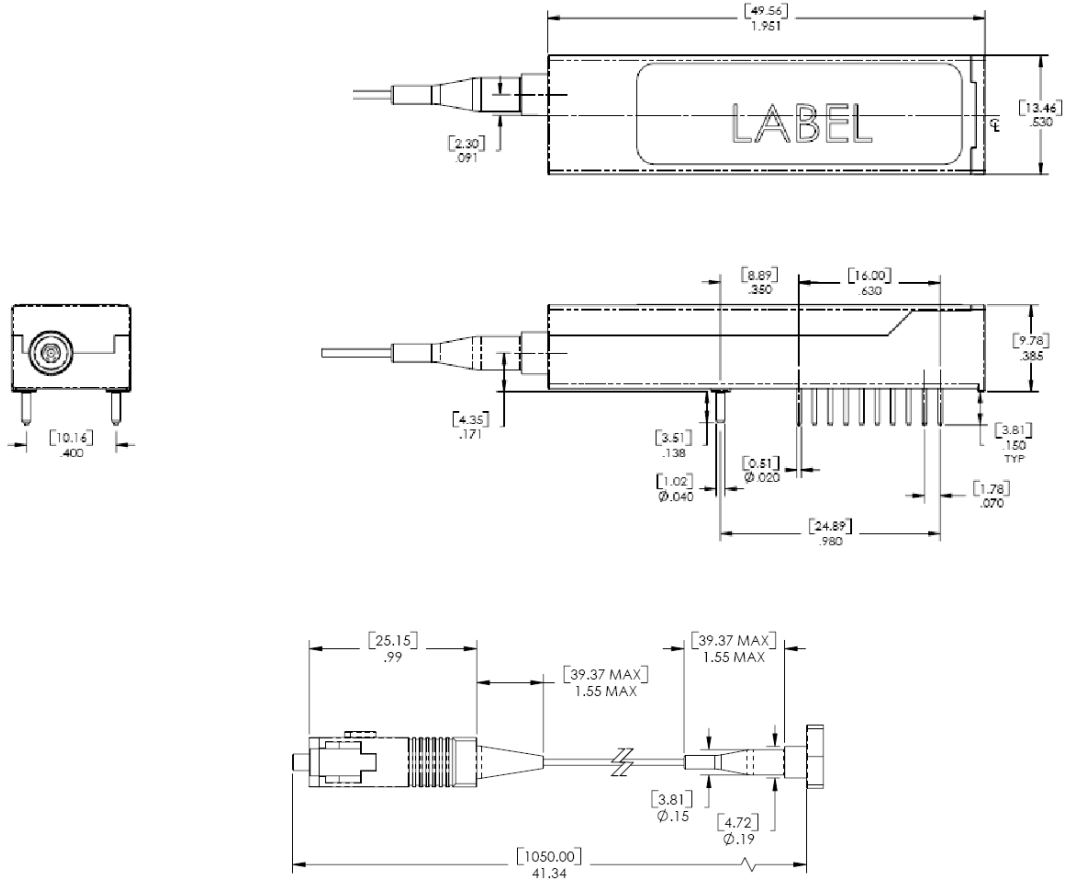

CONNECTOR: SC/UPC AS PER TELCORDIA GR-326

**FTGL2025S1TUx**

## **XII. References**

1. Gigabit-capable Passive Optical Networks (GPON): Physical Media Dependent (PMD) layer specification. ITU-T G.984.2 Class B+, and amendments dated February 2006.
2. Small Form Factor Pluggable (SFP) Transceiver Multi-Source Agreement (MSA), September 2000. Documentation is currently available at Finisar upon request.
3. Small Form Factor (SFF) Transceiver Multi-Source Agreement (MSA). Documentation is currently available at Finisar upon request.

## **XIII. For More Information**

Finisar Corporation  
1389 Moffett Park Drive  
Sunnyvale, CA 94089-1133  
Tel. 1-408-548-1000  
Fax 1-408-541-6138  
[sales@finisar.com](mailto:sales@finisar.com)  
[www.finisar.com](http://www.finisar.com)